



INGRESSI AUTOMATICI AUTOMATIC ENTRANCE

SESAMO s.r.l.
Str. Gabannone, 8/10
15030 Terruggia – AL – ITALY
Tel: +39 0142 403223
Fax: +39 0142 403256
www.sesamo.eu
E-mail: info@sesamo.eu



Organizzazione con Sistema
di Gestione certificato
Company with Management
System certified

ISO 9001:2000



SESAMO REVOLVING DOOR 4 WINGS



SYSTEM:

Four – leaves automatic or manual revolving door which is available in various design options.

Executions with night shutters in manual or automatic version, with electric or mechanical locks, push bars in different variations or specific glass requirements can be realized .

Every 4-leaves automatic revolving door provides a very comfortable 90° wide compartment for any user and person.

The canopy structure is made of a solid and strong steel structure including thermal insulation and clad in aluminum plates along the pelmet and closed with a standard dust cover. The ceiling underside is closed with segmented aluminum plates that provide a solid and perfect flush view.

Highly engineered and reliable drive components ensure a smooth and safe operation at all times.

- Four – leaves revolving doors provide comfort and ideal for office buildings, airports, train-stations, hospitals, shopping centers, hotels and many more
- 90° four leaves turnstile that provides comfortable space to walk through
- Ground position provides high seal and reduces wind draft into building
- Climate control (temperature, air condition wind-drafts) which reduces costs
- Flexible design options provide totally customized solutions for any entrance
- Full glass option available for incredible transparency mainly for glass facades



**INGRESSI AUTOMATICI
AUTOMATIC ENTRANCE**

SESAMO s.r.l.
Str. Gabannone, 8/10
15030 Terruggia – AL – ITALY
Tel: +39 0142 403223
Fax: +39 0142 403256
www.sesamo.eu
E-mail: info@sesamo.eu



Organizzazione con Sistema
di Gestione certificato
Company with Management
System certified

ISO 9001:2000



INSIDE Diameter "U" (drum wall)		
Minimum diameter	1600 mm	approx. 5' - 3"
Maximum diameter	7000 mm	approx. 23'
OUTSIDE Diameter "Q" (canopy pelmet)		
Diameter inside + 58mm (≈ 2 - 2/8") = outside diameter		

Entrance Opening "A" (between cylinder walls)	
Please calculate with underneath formula: Diameter "Q" x 0,707 – 130 = passage width in mm	

Passage Height "G"		
Minimal	2100 mm	approx. 6' - 11"
Maximal	3000 mm	approx. 9' - 10"

Canopy Height "I"			
Minimal	250 mm	≈ 10"	< Ø 3500 mm
Minimal	350 mm	≈ 14"	> Ø 3500 mm
Minimal	400 mm	≈ 16"	> Ø 4800 mm
Minimal	500 mm	≈ 20"	> Ø 6000 mm
Additional	+ 300 mm	approx. 12"	with air curtain

Throughput Capacity (based on bi-directional use)			
2500 mm	3000 mm	3500 mm	4000 mm
≈ 8' - 2"	≈ 10"	≈ 11" - 6"	≈ 13' - 2"
2400 p/h	2450 p/h	3220 p/h	3300 p/h

Above capacity is based on theoretical calculation with maximum occupancy of persons per segment per hour in both directions (without engagement).

Door Speed in U/min (rpm's) *	
For diameter < 2500 mm	Adjustable, max. 5,8 U/min
For diameter < 3500 mm	Adjustable, max. 4,2 U/min
For diameter < 4800 mm	Adjustable, max. 3,2 U/min

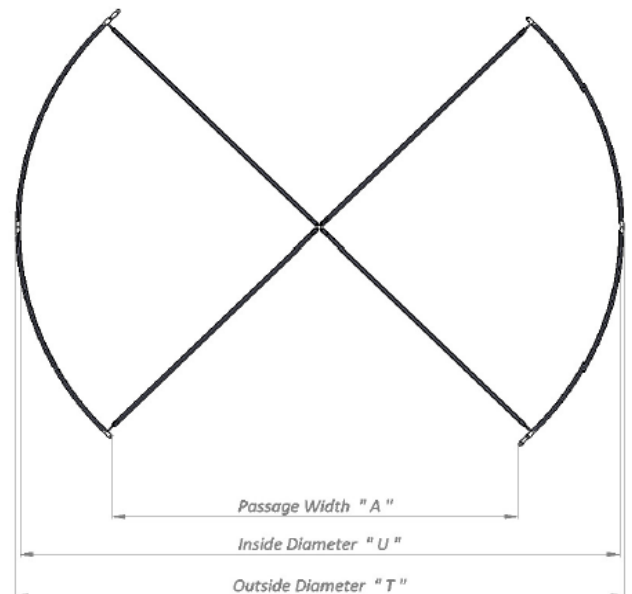
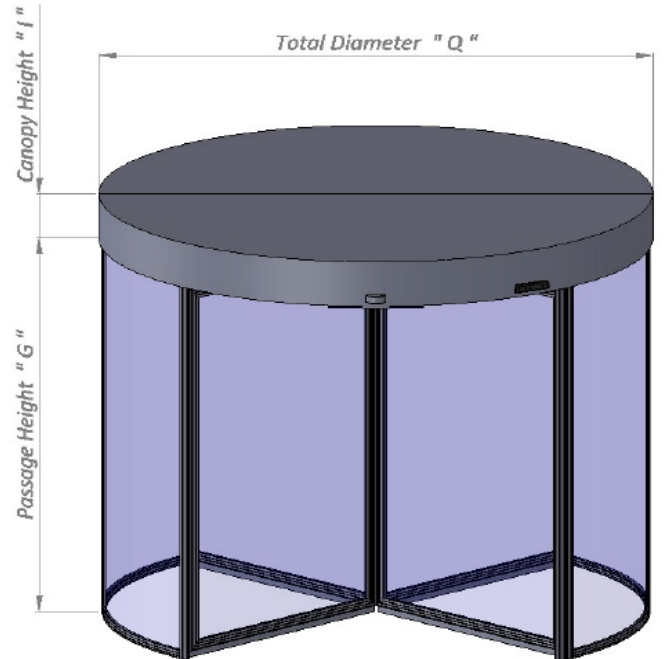

* Please note that the speed needs to be adjusted in accordance to your local codes & requirements



**INGRESSI AUTOMATICI
AUTOMATIC ENTRANCE**

SESAMO s.r.l.
Str. Gabannone, 8/10
15030 Terruggia – AL – ITALY
Tel: +39 0142 403223
Fax: +39 0142 403256
www.sesamo.eu
E-mail: info@sesamo.eu



Organizzazione con Sistema
di Gestione certificato
Company with Management
System certified

ISO 9001:2000



SAFETY FEATURES:

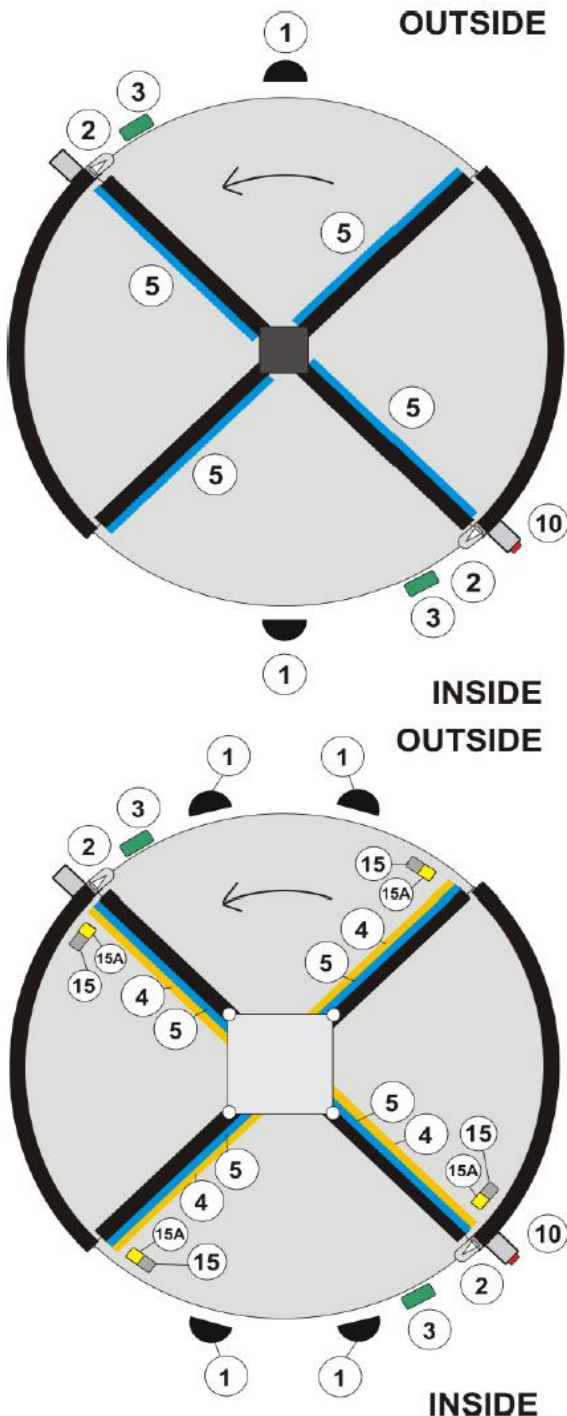

- 1) 2x infrared detector type: **F**
4x when entrance opening is > 2000mm
or
2x motion detector type **RAD290**
4x when entrance opening is > 2000mm
- 2) 2x electro safety strips drum edge "77mm"
- 3) 2x vertical sensors type **I-ON-C**
clear passage height < 3000mm
- 4) 4x sensors strips type: **TOPSAFE (TS)**
mounted at top turnstile door leaf to slow down door
mounting height must be < 3000mm
OPTION for doors < 3000 mm (9' – 10")
STANDARD for doors > 3000 mm (9' – 10")
- 5) 4x electro safety strips heel protection "45mm"
- 15) 4x presence detector vertically in front of leading door leaf
type: **TOPSAFE-TS**
- 15a) 4x forward sensor type: **W-LP** if passage height > 3000mm
- 10) 1x emergency stop switch (behind glass) mounted in the
vertical support tube 1x inside mounting height 1200mm
 - operating switch with standard key, mounting height 1200mm (OFF – AUTO – CONTINUOUS - HAND)
 - 4x label (decal mandatory signs) "mother and child / dog"
 - 2x slow down push button mounting height 800mm (OPTIONAL 1x outside & 1x inside)
 - 1x emergency operating key switch mounted in the tube (OPTIONAL 1x inside)
 - 1x IBS – "digital error and program display system (OPTIONAL 1x inside)
 - electromechanical bistable locking 24V DC (OPTIONAL 1x inside the canopy)



key operating switch
inside as standard



emergency stop switch
inside as standard



slow down push button
inside and outside *optionally*



emergency operating key switch
inside *optionally*

NOTE: Above diagrams show only basic location of safety features without obligation.



**INGRESSI AUTOMATICI
AUTOMATIC ENTRANCE**

SESAMO s.r.l.
Str. Gabannone, 8/10
15030 Terruggia – AL – ITALY
Tel: +39 0142 403223
Fax: +39 0142 403256
www.sesamo.eu
E-mail: info@sesamo.eu



Organizzazione con Sistema
di Gestione certificato
Company with Management
System certified

ISO 9001:2000



DESIGN FEATURES:

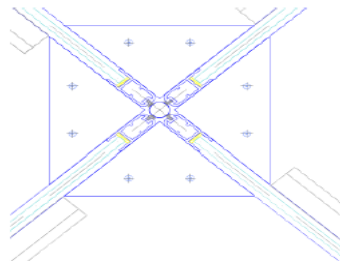
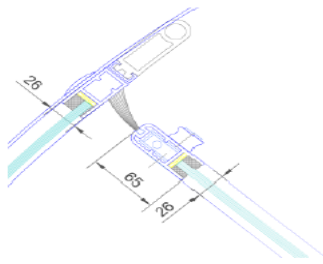

- basic design with slim 26mm x 65mm profiles for automatic and manual revolving doors
- robust and self supporting steel or aluminium structure
- natural horse-hair brush seals
- wet glazing (silicone) that provides a high durability

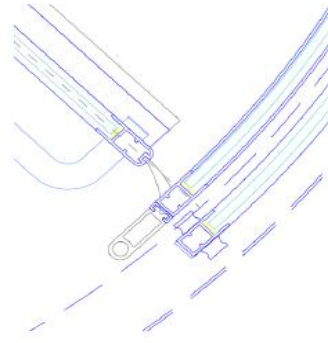
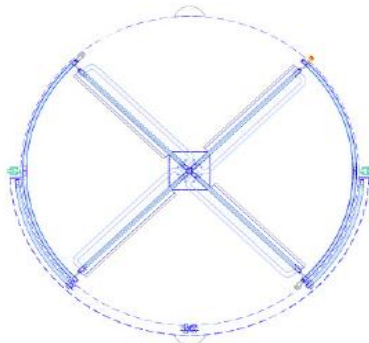

- night-shutter available in manual or automatic version
- outside or inside of cylinder walls (drum) possible
- in glass or panel construction
- with full or half profile cylinder lock available
- keeps entrance clean at night and provides higher security

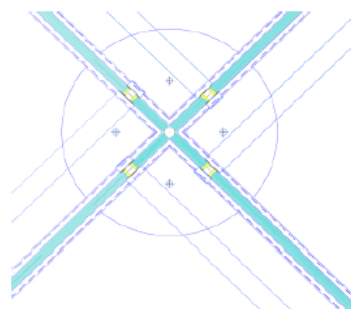
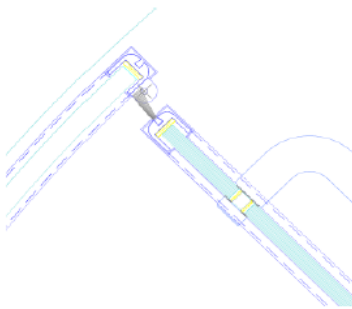

- vitro design for manual revolving doors
- super slim profiles with 26mm x 27mm
- horizontal stainless steel handles for stability
- middle of turnstile without any profiles

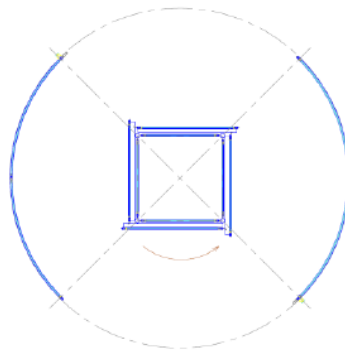
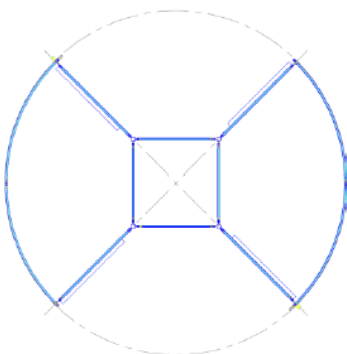

- middle show-case (display) for larger revolving doors with lockable accessible leaf
- straight, concave- or convex-curved show case executions possible
- allows the handling of large goods through the door and supports escape routes as all leaves are collapsible



INGRESSI AUTOMATICI AUTOMATIC ENTRANCE

SESAMO s.r.l.
Str. Gabannone, 8/10
15030 Terruggia – AL – ITALY
Tel: +39 0142 403223
Fax: +39 0142 403256
www.sesamo.eu
E-mail: info@sesamo.eu



Organizzazione con Sistema
di Gestione certificato
Company with Management
System certified

ISO 9001:2000



BASIC EQUIPMENT:

The door is supplied including the following basic parts and features:

1 no. Operating switch with following modes:

(OFF– Automatic – Continuous – Hand)

1 no. Emergency Stop Switch

OPTIONAL:

1 no. Digital status and error display

2 no. Slow down push buttons

Including all necessary safety features as required by latest standards (refer to page 3).

SURFACE:

The surface can be provided in any standard RAL powder coating or standard anodizing where we provides and uses the highest quality. Stainless steel clad surface in quality 304 or 316, bronze or brass are also possible on a totally bespoke execution.

BASIC OPTIONS:

- Floor Ring (substructure) in stainless steel to receive matting for 17, 22 or 25mm
- floor-mat by with felt strips in anthracite or other colors, height 22mm
- 3, 6 or 9 pc. LED spot lights integrated in the rotation ceiling ; 12 V DC and 1,2 Watt
- 3, 6 or 9 pc. Halogen spot lights integrated in the rotation ceiling ; 12 V DC and 20 Watt
- 3 pc. Horizontal or vertical push bars in different design options available. Standard push bars in stainless steel 304 diameter 30mm
- Watertight roof at outside (180°) including two water spouts to drain the water
- Dust roof 180° or 360° in aluminum raw, RAL, anodized, stainless steel etc.....
- Air curtain (heater) including air duct and air outtake for electrical or warm water supplies
- Monitoring contacts for door position and lock status (low voltage, NO)

GLAZING:

The drum walls are made of special slim aluminum extrusions with a size of only 65mm x 26mm (height x width) and glazed with clear 10,76mm curved laminated safety glass and 8mm clear straight single toughened safety glass. Typical is a single sheet tempered safety glass with 10mm used.

DESIGN OPTIONS:

- Low iron glass (White-Glass); tinted glass and special glasses on request
- Drum walls solid panel construction, framed or flush instead of drum walls with glass
- Night shutter (2x 30° leaves) outside or inside available in various options
- Mid-rails (muonting) at drum walls or rotating centerpiece, impact protection from trolleys
- Individual design executions possible on request such as signage, special illumination etc.
- 3 manually foldable door leafs for transportation purposes or supporting escape routes (break-out) with book fold design
- Middle show-case (display) in straight, concave or convex design that starts from diameters with 3200mm (approx. 10'), all three door leaves will be manually collapsible and during normal operation hold with electromagnets
- VITRO – design (full glass execution) available for up to 3000mm in diameter (9' - 9'') with a maximum total height of 4000mm (13'), this design requires horizontal push bars to stabilize the turnstile
- Column – drive that will allow to build the door around a structural existing steel or concrete column (pillar), provides solutions even for narrow spaces where revolvers can be used
- Individually design option always possible, please contact your local sales partner



**INGRESSI AUTOMATICI
AUTOMATIC ENTRANCE**

SESAMO s.r.l.
Str. Gabannone, 8/10
15030 Terruggia – AL – ITALY
Tel: +39 0142 403223
Fax: +39 0142 403256
www.sesamo.eu
E-mail: info@sesamo.eu



Organizzazione con Sistema
di Gestione certificato
Company with Management
System certified

ISO 9001:2000



TECHNICAL DATA:

Power supply	230V AC or 120 V AC, 50 - 60Hz
Power connection	single phase alternative current, fused 16 Ampere
Power consumption	250 Watt (∅ 2000mm); 1600 Watt (∅ 6000mm)
Control Unit	24V DC (short-circuit-proof)
Motor Current	48V DC (pulsed)

- all cables and conduits has to be supplied by others
- optionally monitoring contacts for status of lock and door position (potential free, NO)
- optionally monitoring contacts for door interruptions and status (potential free, NO)

ENVIRONMENTAL CONDITIONS:

Temperature Range	-15°C (45°F) up to + 50°C (105°F)
Humidity Range	up to 85% relative humidity
Case Protection	IP 20



SESAMO, IMPROVE YOUR LIFE