

# TWENTY

Aluminium profiles for doors and windows



Organizzazione con Sistema  
di Gestione certificato  
*Company with Management  
System certified*

ISO 9001:2000



I N S T A L L A T I O N M A N U A L



# CERTIFICATO

L'Organismo di Certificazione TÜV Rheinland Group  
certifica, in accordo alle procedure TÜV Rheinland Group, che l'azienda

**SESAMO S.r.l.**  
Strada Gabannone, 8/10  
I - 15030 Terruggia (AL)

ha istituito ed attua un sistema di gestione per la qualità  
relativo al seguente campo di applicazione:

**Progettazione e produzione di  
porte automatiche.** EA 17, 18

Mediante un audit, rapporto N° 1130610, è stata conseguita  
dimostrazione che le prescrizioni della norma

**UNI EN ISO 9001:2000**

sono soddisfatte.

Fare riferimento al Manuale della Qualità per  
i dettagli sulle esclusioni rispetto ai requisiti della norma.

N° di registrazione del certificato: **39 00 1130610.**

La validità del presente certificato è subordinata a sorveglianza  
periodica annuale / semestrale ed al riesame completo  
del sistema di gestione aziendale con periodicità triennale.

Milano, li 17/10/2006.

L'Organismo di Certificazione  
TÜV Rheinland Group



SGQ N° 083A  
Membro degli Accordi di Mutuo Riconoscimento EA ed IAF  
Signatory of EA and IAF Mutual Recognition Agreements

www.tuv.com



TÜV Rheinland Group

**Contents**

Introduction ..... pag. 3  
 Presentation ..... pag. 4  
 Labprofiles ..... pag. 4  
 Purpose and use of the manual..... pag. 4  
 TWENTY series profile list..... pag. 5  
 Wings components diagram..... pag. 6  
     Sliding wing ..... pag. 6  
     Fixed wing ..... pag. 7  
     Transom-window..... pag. 8  
     Assembly diagrams..... pag. 9  
 Sliding wing assembly diagrams..... pag. 10  
 Fixed wing assembly diagrams..... pag. 11  
 Frames components diagrams..... pag. 12  
     Wall mounted frame components for sliding wings..... pag. 12  
     Wall mounted frame components for sliding and fixed wings..... pag. 13  
     Frame on corridor components..... pag. 14  
 Glass assembly diagram..... pag. 15

**Introduction**

We would like to thank you for choosing this product.

In order to optimize the assembly and installation of the TWENTY profiles, the Sesamo Company recommends that you read and carefully follow the installation and use instructions provided in this manual. The installation must be performed only by professionally qualified personnel for whom this manual has been written. Any errors during the installation phase may be the source of danger for people or things. The packaging materials (wood, plastic, cardboard, etc.) should not be discarded in the environment or left within reach of children since they are potential sources of danger. Every individual installation phase must be performed in conformity with current regulations and according to Good Practice principles. Ensure, before beginning the installation, that the product is complete and has not been damaged during transport or as a result of improper storage. Before installing the product ensure that each architectonic and structural element of the entrance is suitable and sufficiently sturdy to be automated. Conduct a careful analysis of the risks and make appropriate modifications to eliminate the areas of dragging, crushing, shearing and other generally dangerous areas. SESAMO is not responsible for any non-compliance with "good practice" or specific regulations during the construction of the frame to be motorized. All the protective safety devices of the automatic door (photocells, active sensors, etc.) must be installed in conformity with the regulations and directives in force, the analysis of the risks carried out, the typology of the system, the use, the traffic, the forces and inertia in play. Always pay particular attention to the zones where the following may occur: crushing, shearing, dragging and any other danger in general, placing appropriate signs as needed.

Use only original spare parts in the maintenance or repair operations.

The TWENTY profiles have been designed for the realization of automatic entrances and are also available with antipanic systems. Any other use will be considered contrary to the use foreseen by the manufacturer who, consequently, cannot be held liable.

## Presentation

### THE VERSATILE AND INNOVATIVE PROFILE FOR SLIDING DOORS

A profile with soft features and reduced dimensions, the best technology has to offer with a modern, sophisticated design. Specially designed to create single or multiple-wing doors which are perfectly functional and aesthetically flawless, its delicate linear forms make it suitable for a wide variety of entrances, from residential to public, meeting even the most particular needs.

This line is at the forefront in offering a high-quality product able to enhance the transparency of the glass and add elegance to any architectural project.

An innovative product with technical characteristics and high performance together with an essential and elegant design, TWENTY is distinguished by its flexibility and simple assembly that reduces and optimizes the work time required; it is versatile and innovative not only in its form but also its substance.

The development, testing and production of TWENTY are carried out, as for all SESAMO products, according to the international standard ISO 9001.

## Labprofiles

A unique instrument that SESAMO makes available to its customers is the LABPROFILES software, completely free and downloadable from the site [www.sesamo.eu](http://www.sesamo.eu).

LABPROFILES allows to generate the vertical and horizontal sections, the components list, accessories list and cut list in order to realize a complete sliding system.

The insight of the menu, the detailed graphics, the possibility to make blowups and printouts of the profiles in order to highlight the nodes and the labels on the individual components represented in the pictures guarantee a very intuitive and immediate use without requiring particular computer knowledge.

LABPROFILES includes a large variety of predetermined solutions, personalizable by the user. It is however possible to realize entrances different from those predetermined thanks to the software flexibility.

## Purpose and use of the manual

This manual is complementary to LABPROFILES to which it refers for information necessary for the choice, cut and working of the profiles and their completion with the relative accessories; it is subdivided into three main sections.

The first in which the Twenty series is presented graphically, showing the characteristic dimensions.

The second section in which the essential elements of an automatic entrance (sliding wing, fixed wing, etc.) are schematized and the constituent components are highlighted with reference to the relative assembly diagram.

The third section concerns the assembly of the various elements with different glass thickness.

TWENTY series profiles list

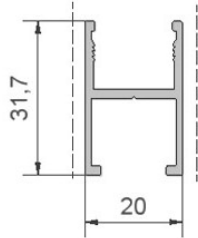

PF17.01

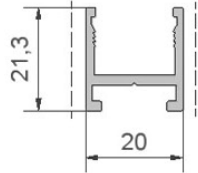

PF17.02

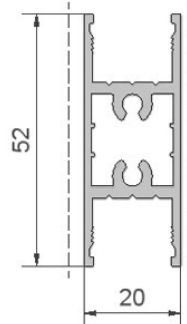

PF17.03

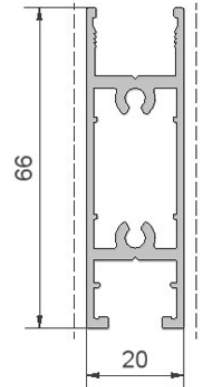

PF17.04

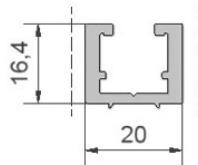

PF17.05

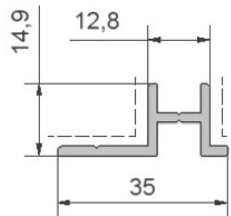

PF17.06

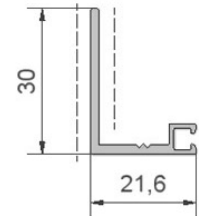

PF17.07

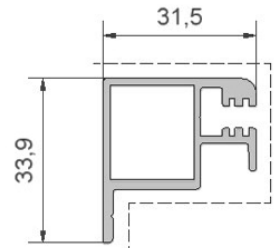

PF17.08

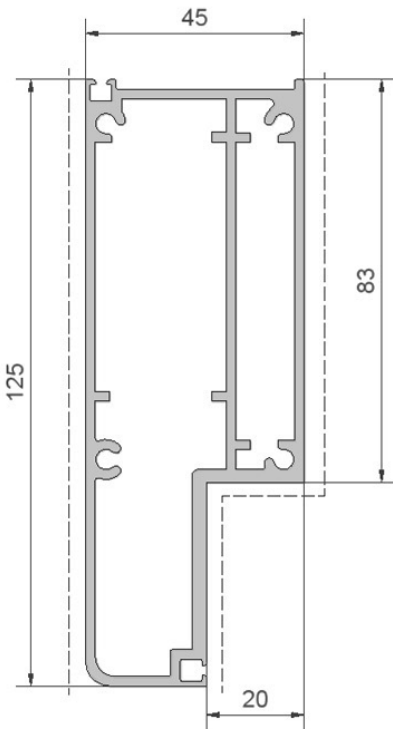

PF17.11

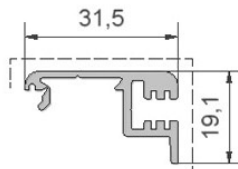

PF17.09

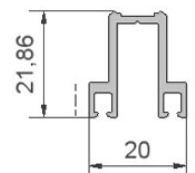

PF17.10

----- in sight area

Code	Description	weight (Kg/m)	L (mm)
PF17.01	Upright	0.365	5100
PF17.02	Low upright	0.294	5100
PF17.03	Band	0.799	5100
PF17.04	Crosspiece	0.945	5100
PF17.05	Sliding adapter	0.389	5100
PF17.06	Fixed adapter	0.316	5100
PF17.07	Fixed L	0.248	5100
PF17.08	Photocel door	0.589	5100
PF17.09	Labyrinth	0.365	5100
PF17.10	Guide track	0.292	5100
PF17.11	Transom-window profile	2.651	6820

Sliding wing components

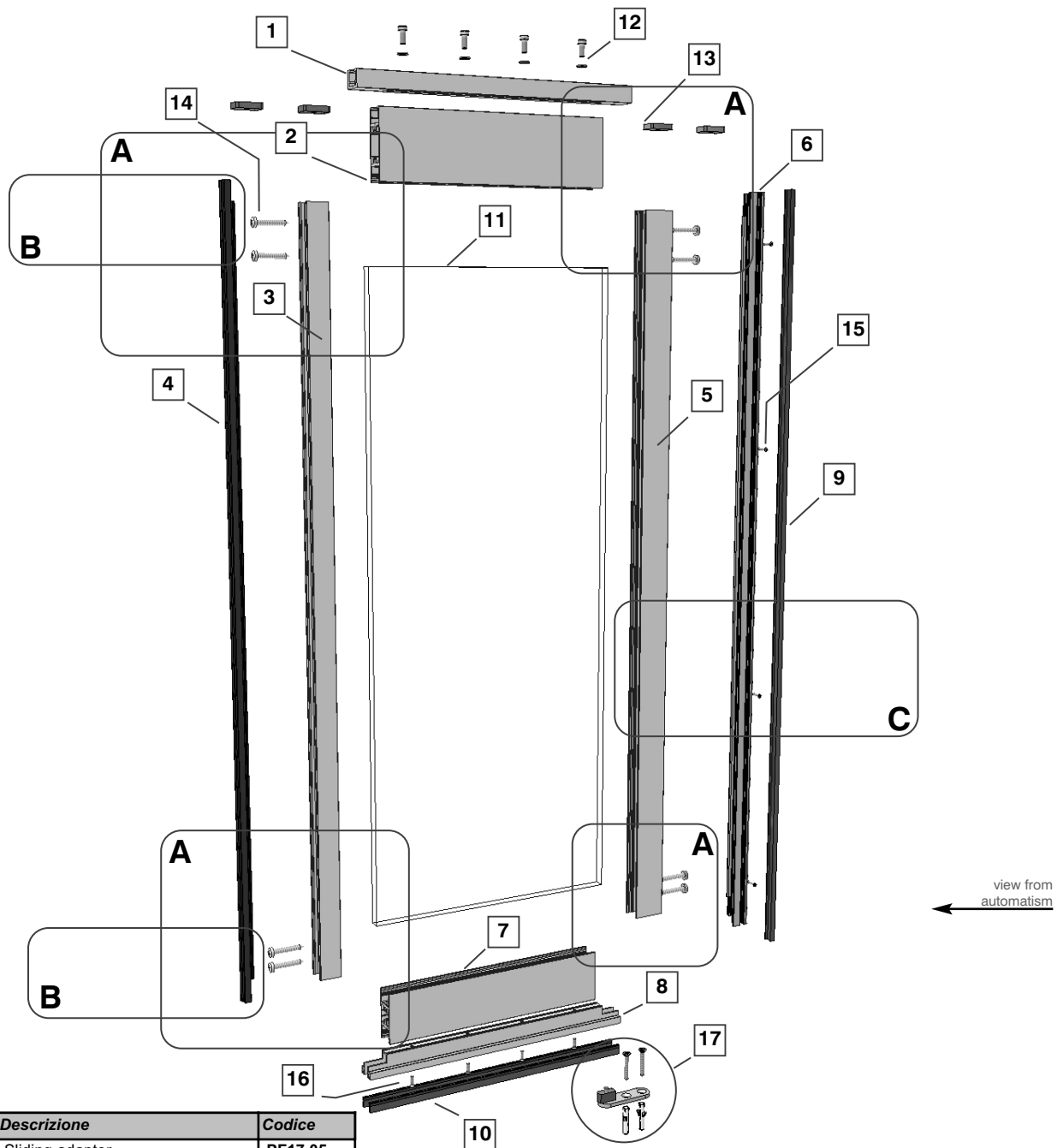

PROFILI	n°	Descrizione	Codice
	1	Sliding adapter	PF17.05
	2	Crosspiece	PF17.04
	3	Lower upright	PF17.02
	4	Gasket	PF17.12
	5	Upright	PF17.01
	6	Labyrinth	PF17.09
	7	Band	PF17.03
	8	Guide track	PF17.10
	9	Narrow soft brush	PF03.26
	10	10mm brush	PF17.13
11	Glass	-	
ACCESSORI	Accessories kit for sliding wing		PF17.17
	12	Screws VTC M5x12	
	13	Plates	
	14	Screws autofilettanti VTC 4.8x32	
	15	Screws autofilettanti VTS 2.2x13	
	16	Screws autofilettanti VTS 2.9x13	
	17	Sliding wing	PF17.18
	18	Accessories kit for glass divider	PF17.20

Standard wing with band

Same diagram assembly of the standard wing adding a band profile PF17.03 fixed as horizontal divider.

Modify the profiles PF17.02 and PF17.01, of the external frame, in order to admit the assembly of the band profile using the components of the optional accessories kit PF17.20

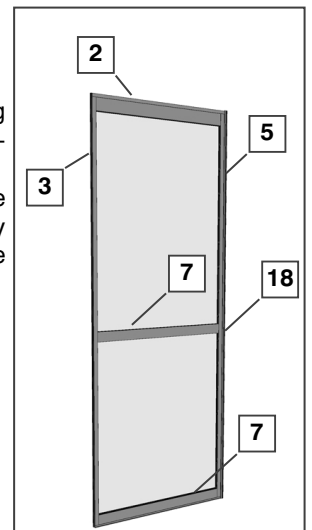

optional

Fixed wing components

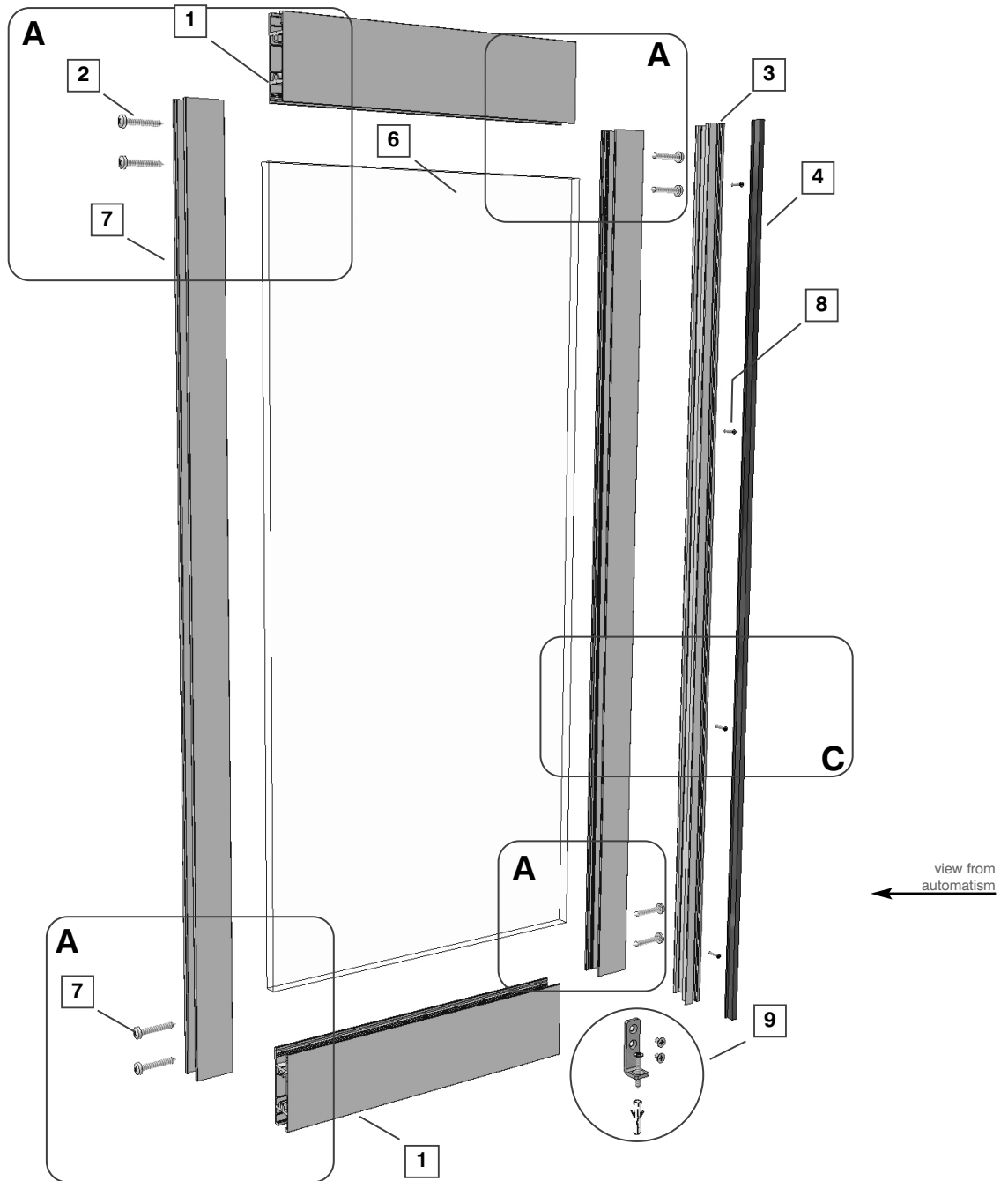

Standard frame with band

Same diagram assembly of the standard wing adding a band profile PF17.03 fixed as horizontal divider.

Modify the profiles PF17.02 and PF17.01, of the external frame, in order to admit the assembly of the band profile using the components of the optional accessories kit PF17.20

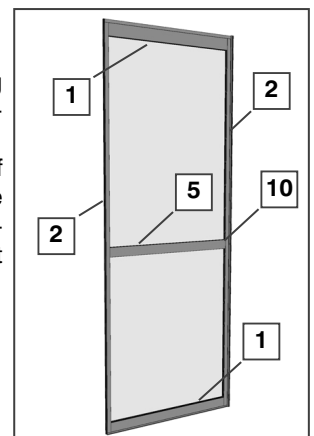

	n°	Descrizione	Codice
PROFILES	1	Crosspiece	PF17.04
	2	Upright	PF17.01
	3	Labyrinth	PF17.09
	4	Narrow soft brush	PF03.26
	5	Band	PF17.03
ACCESSORIES	6	Glass	-
		Accessories kit for fixed wing	PF17.16
	7	Screws VTC 4.8x32	
	8	Screws VTS 2.2x13	
	9	Floor assembly kit	
	10	Accessories kit for glass divider	PF17.20

optional

Transom-window components

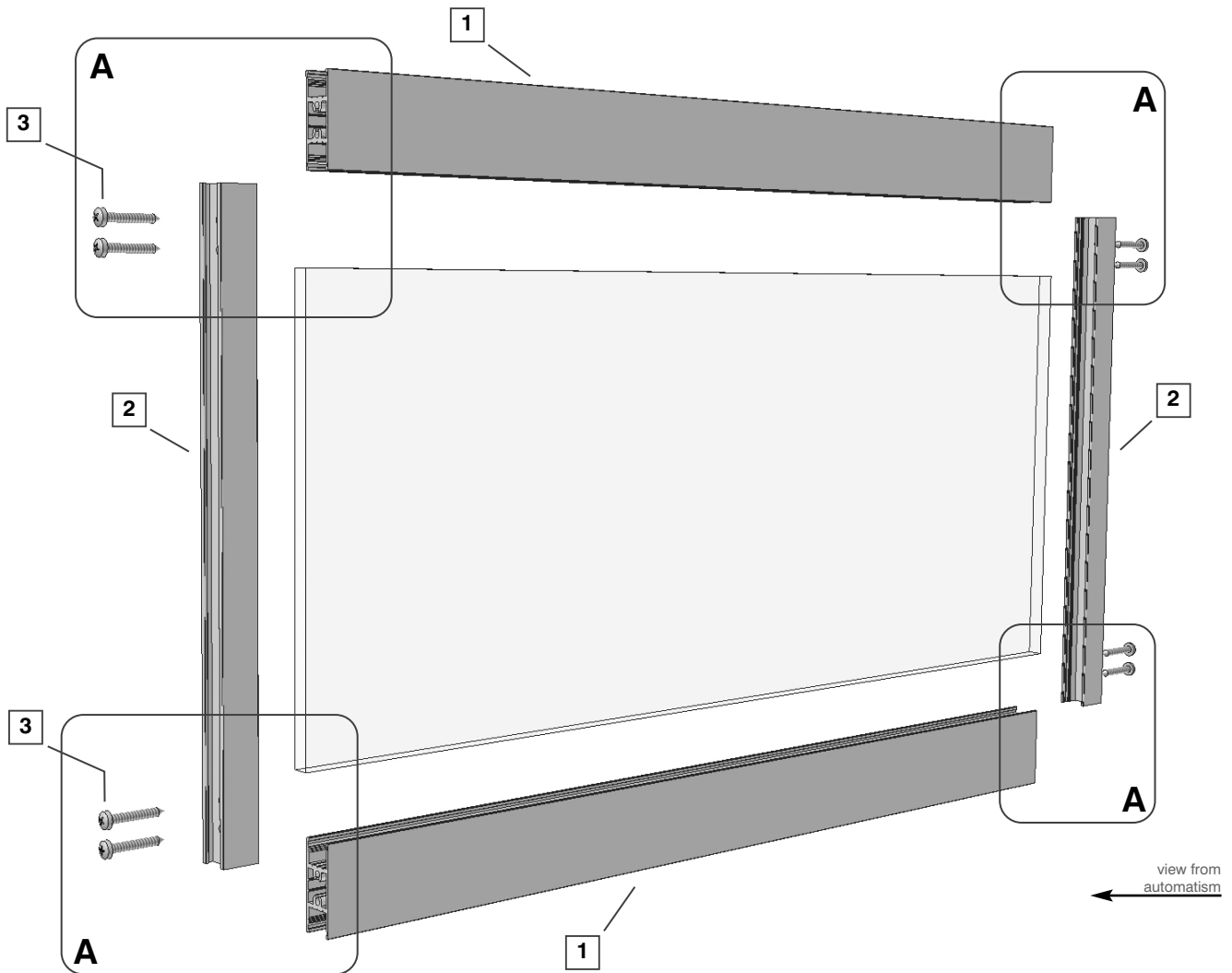

**Transom-window with band**

Same standard wing assembly scheme with further band profile PF17.03 assembled like vertical divider. Modify the frame profiles PF17.03 in order to admit the assembly of the band profile using the components of the optional accessories kit PF17.20

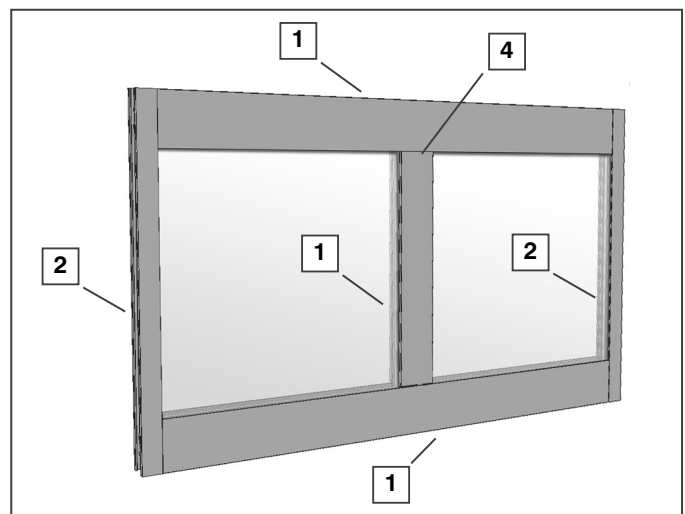

n°	Descrizione	Codice
1	Band	PF17.03
2	Low upright	PF17.02
3	Screws VTC 4.8x32	-
4	Glass divider kit	PF17.20

optional

Assembly diagrams

**assembly scheme A**

Place profile PF17.01 and PF17.02 beside profile PF17.03 and PF17.04.  
Insert the screws PF03.77 into the special holes on profile PF17.01 and PF17.02 and screw them on so as to obtain a solid assembly of the two aluminium profiles.

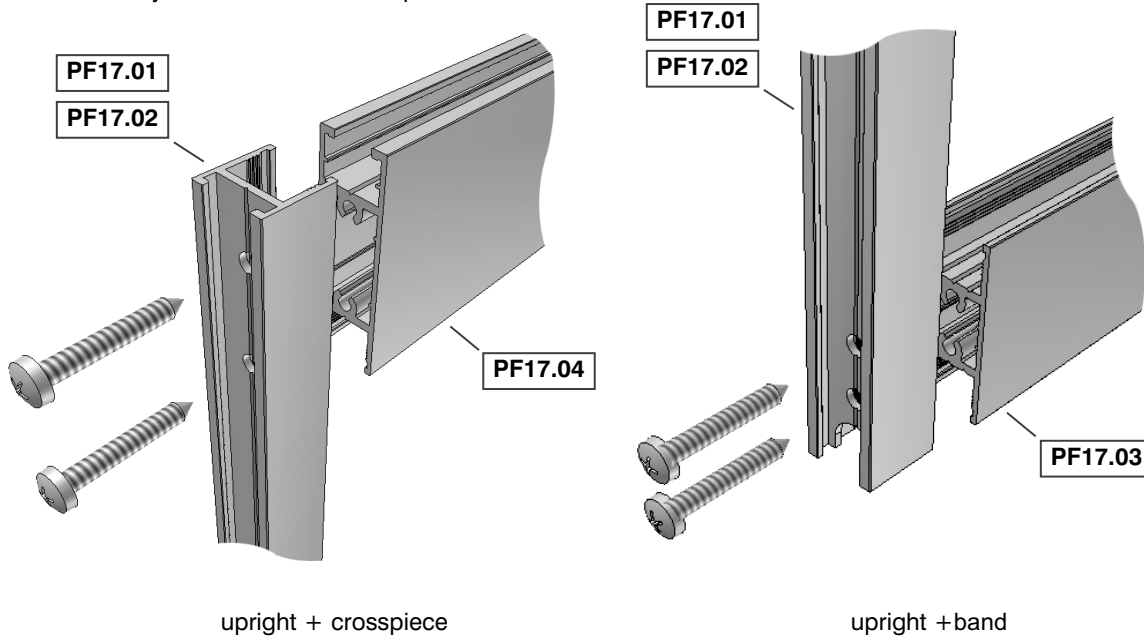

**assembly scheme B**

Cut the gasket profile (about 20mm) as shown in the picture, at both ends of the gasket

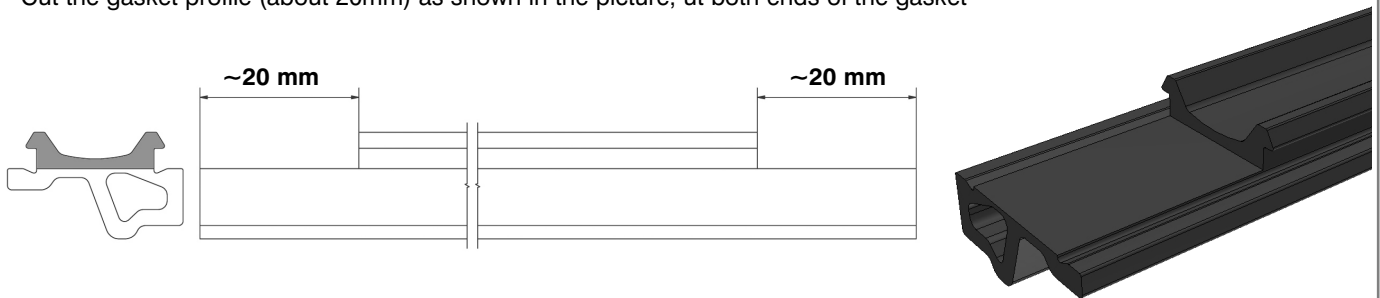

**assembly scheme C**

Mount profile PF17.09 on the profile PF17.01 in the correct position; bore the two profiles and unite them with screws. Insert the brush PF03.26 into the special seat.

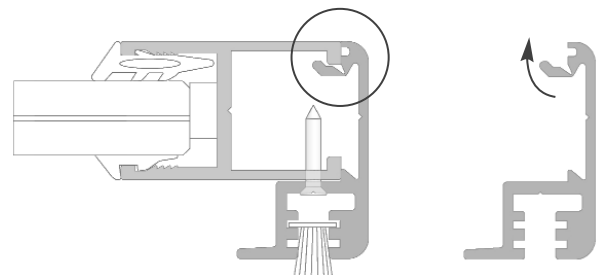
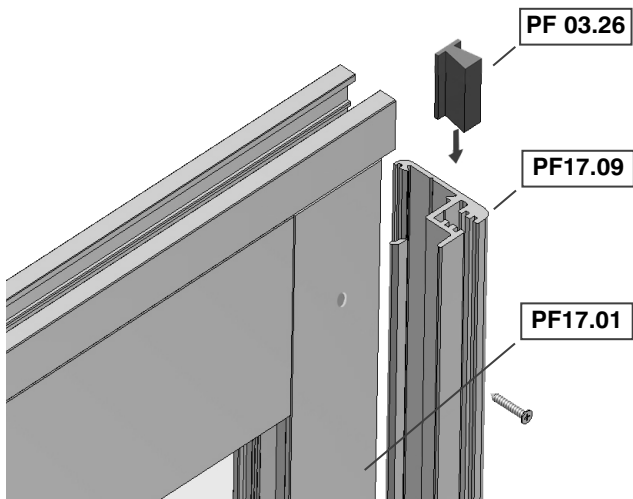

**CAUTION:** be carefully to fit the labyrinth and the upright profiles in the correct position along the entire profile length. If necessary deforming the fin to improve the fitting effect of the two profiles

Sliding wings assembly diagrams

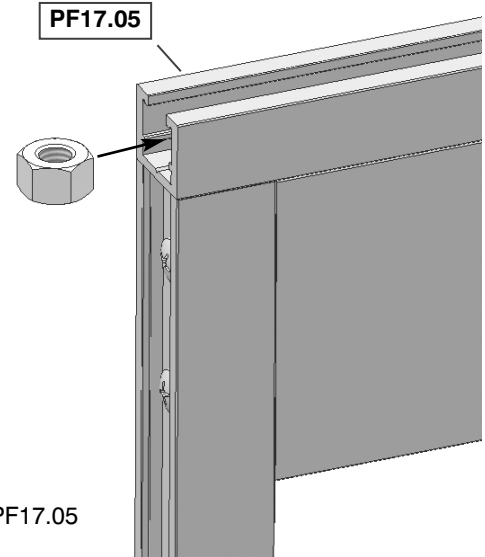
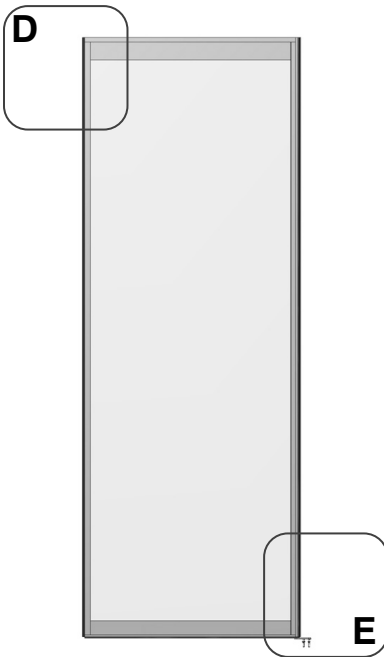

**assembly scheme D**

To assembly the sliding wing to the cart remind to insert the M8 bolts in the PF17.05 profile seat before apply the finish profiles of the wing (gasket, labyrinth,...)

**assembly scheme E**

Adjust the height of the sliding wing so that it is approximately 8mm, control the distance along the entire run. Move the wing into the closed position, slip the sliding block into the special seat and set out the position of the and guide PF17.18 as shown in the picture. Fasten to the floor with a 6mm plug at the central hole of the plate. The two fastening holes allow to perform a slight adjustment of the position of the sliding block axis by rotating the plate around the axis of the central hole. When the ideal position has been obtained, mark the centre of the hole for the second plug and fasten it.

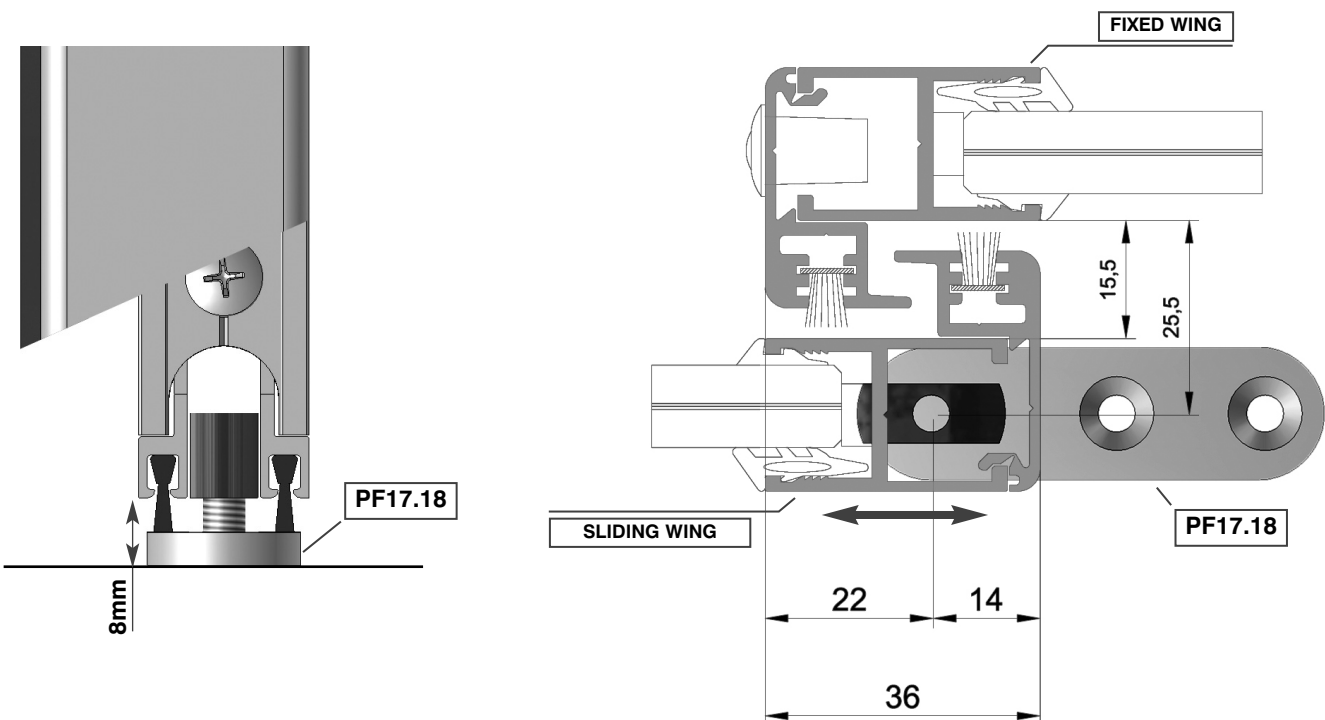

Fixed wings assembly diagrams

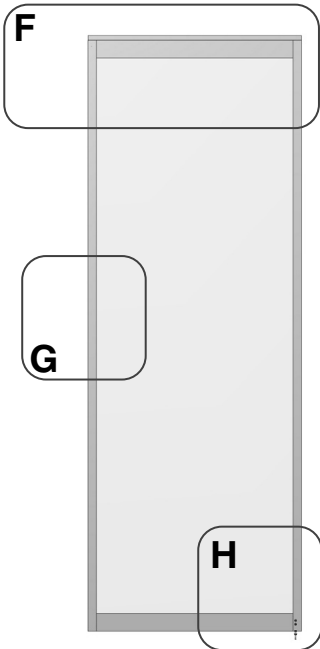

**assembly scheme F**

Bore the PF 17.07 profile along the cavity and fixed it to the wing.

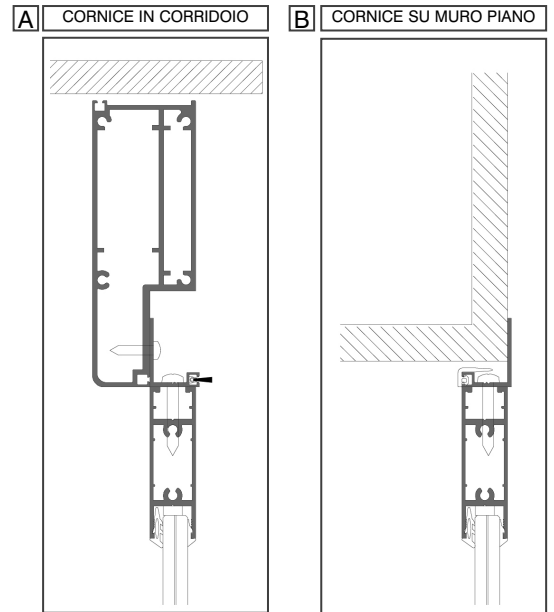
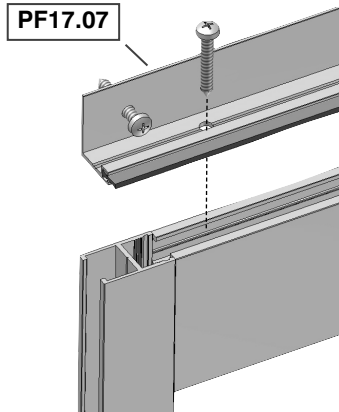

**A-** In case of frame on corridor assembly the PF17.07 profile to the profile PF17.11 fixing it with screws.

**B-** In case of wall mounted frame fix the profile to the wall as shown in the scheme

**! CAUTION:** The PF17.07 profile is divided in different parts driven by the entrance layout: one part for the fixed wing and one for the entrance area

Place the 17.07 profiles keeping as point of start the wall beside the fixed wing in order to match the two part of the fixed L in the middle of the upright wing profile.

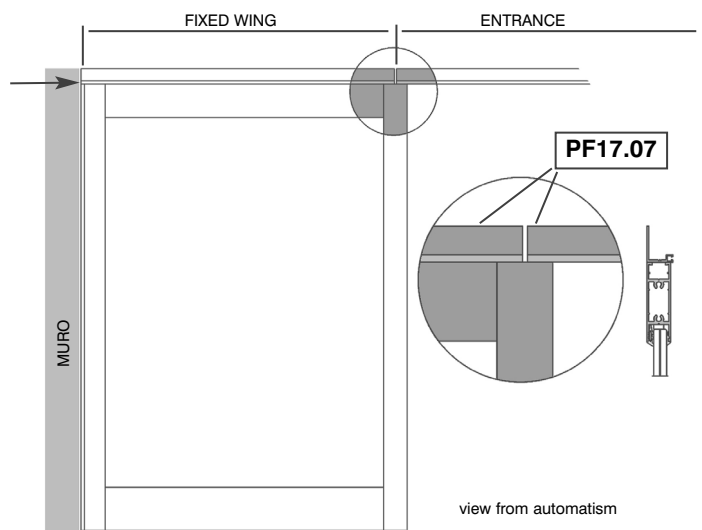

**assembly scheme G**

Before assembly the wing to the floor, match the wing upright profile PF17.1 to the PF 17.06 profile fixed to the wall.

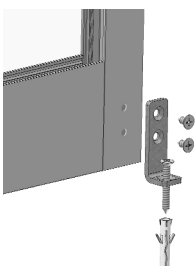
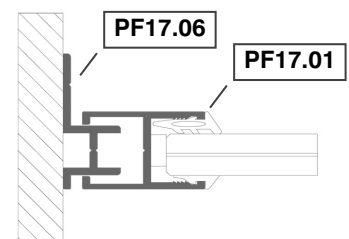

**assembly scheme H**

Assembly the bracket to the fixed wing upright with two screws. Obtain the correct position of the wing and fasten it to the floor with plug and screw.

Wall mounted frame components for sliding wings

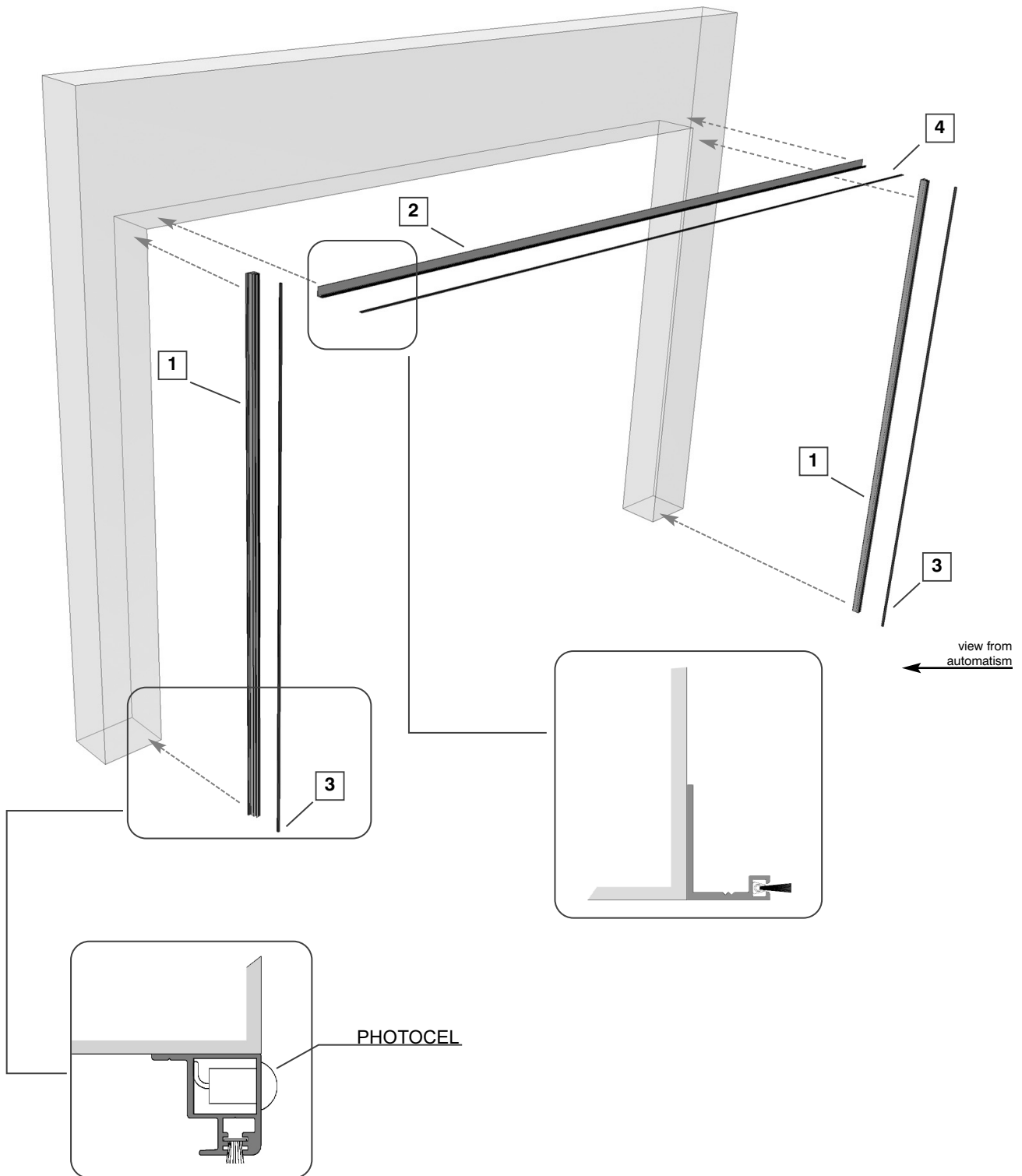

n°	Descrizione	Codice
1	Photocel door	PF17.08
2	Fixed L	PF17.07
3	Pennellino morbido stretto	PF03.26
4	10mm brush	PF17.13

Wall mounted frame for sliding and fixed wings

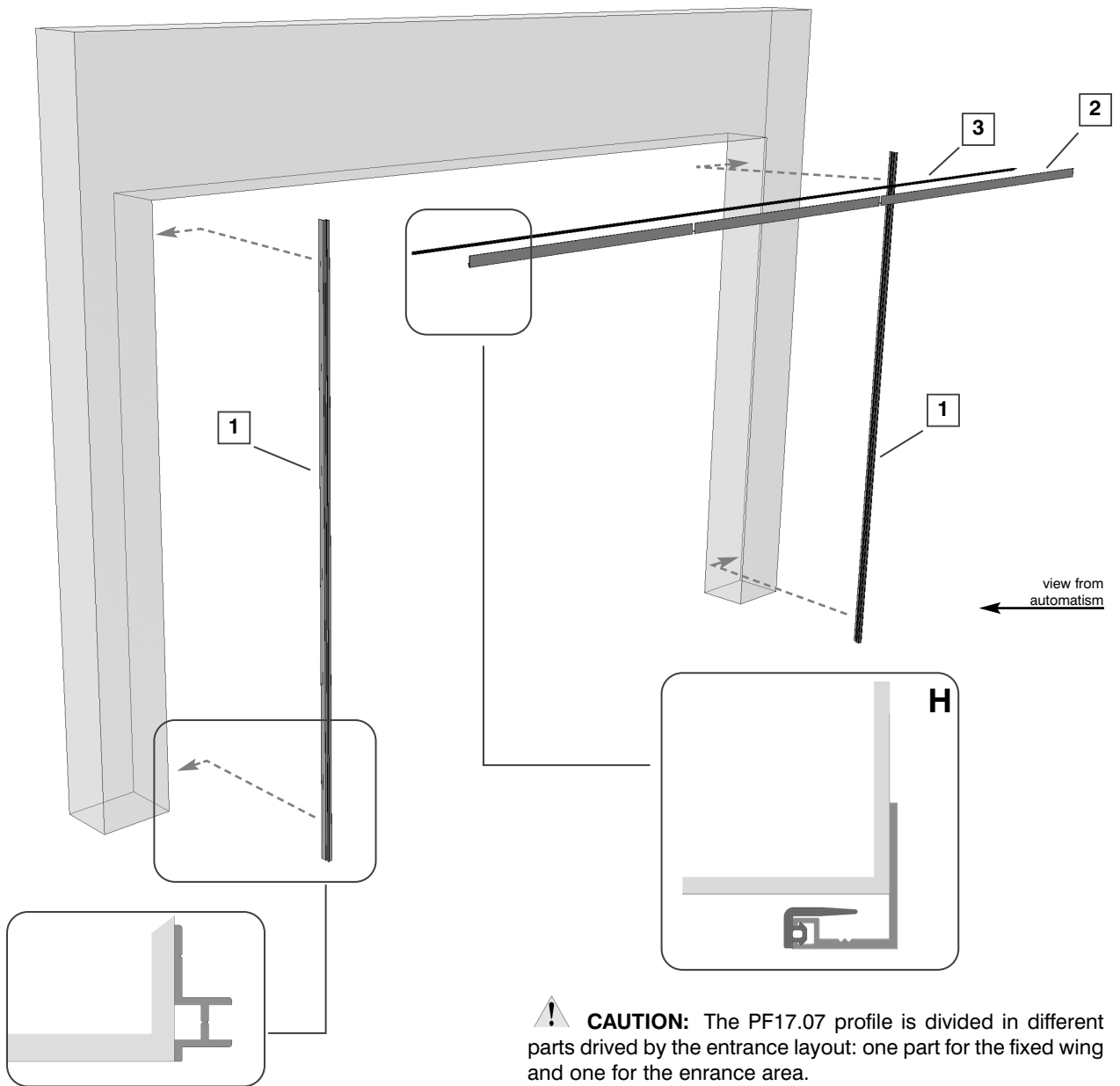

**CAUTION:** The PF17.07 profile is divided in different parts driven by the entrance layout: one part for the fixed wing and one for the entrance area.

n°	Descrizione	Codice
1	Fixed adapter	PF 17.06
2	Fixed L	PF 17.07
3	Gasket	PF17.14

**assembly scheme H**

To place the profile PF 17.07 fold and modify the gasket PF 17.14 in order to supprime the gap between the profile and the wall.

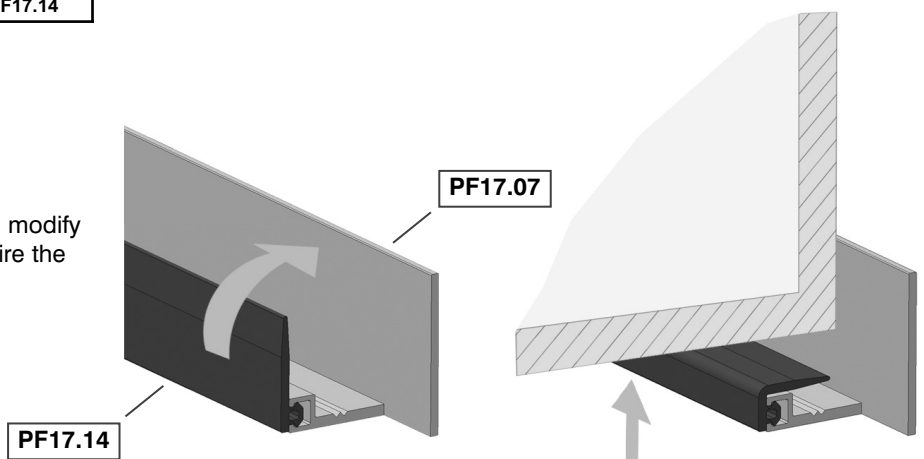

Corridor frame components

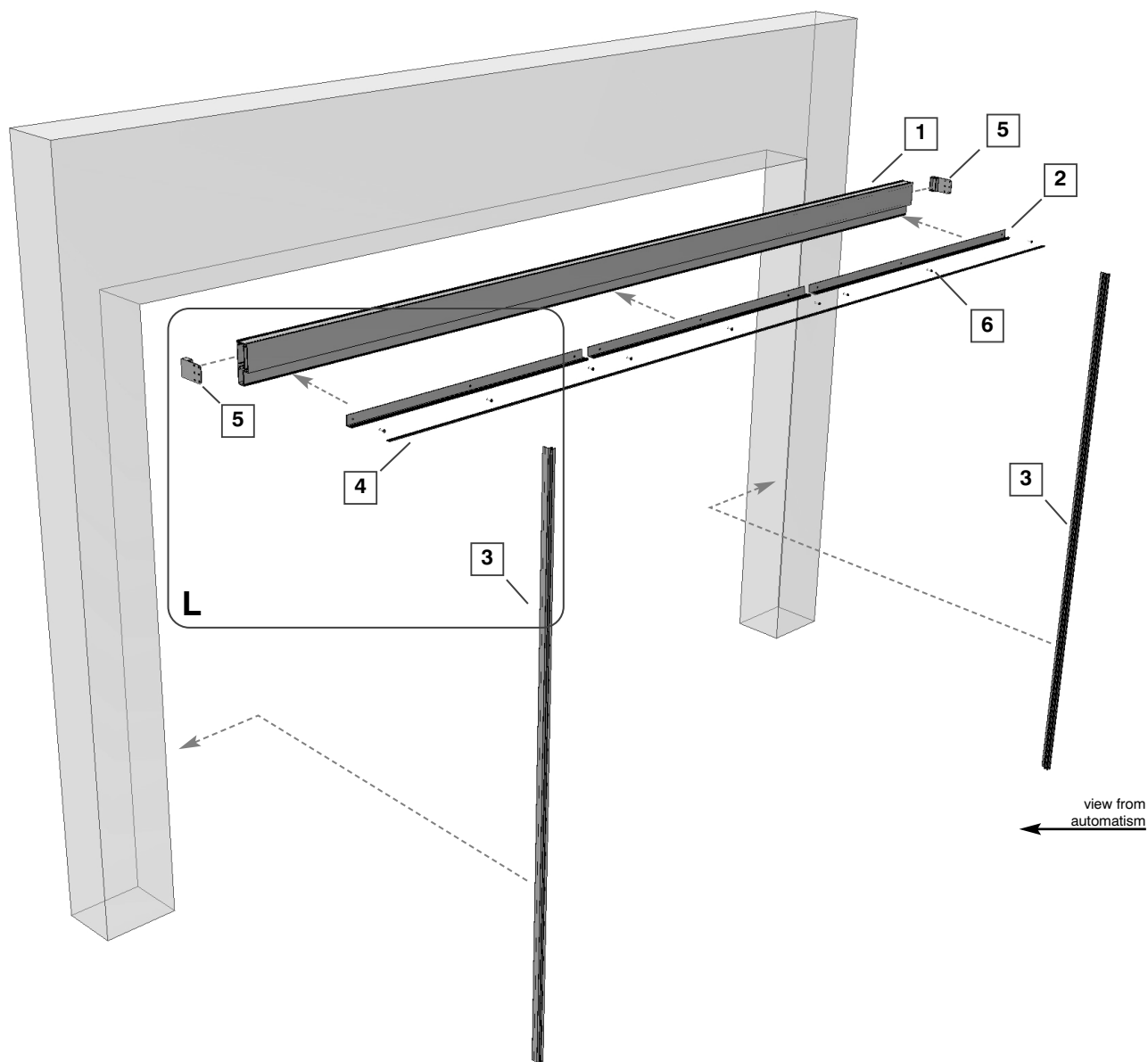

assembly scheme L

Assembly the transom-window profile PF17.13 with the components of the PF 17.20 Kit (corridor frame assembly Kit)  
Place the PF17.07 profile against the PF17.11 transom-window profile and fix it with screws.

**CAUTION:** The PF17.07 profile is divided in different parts driven by the entrance layout: one part for the fixed wing and one for the entrance area.

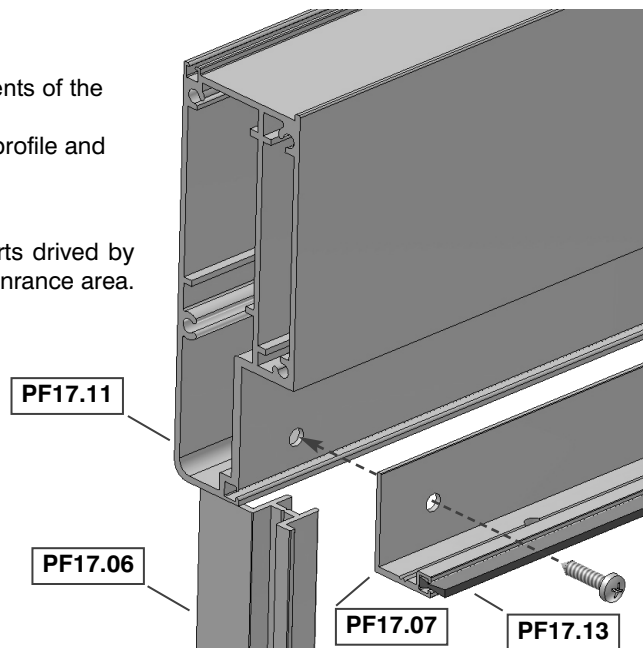

n°	Descrizione	Codice
1	Crosspiece	PF17.11
2	Fixed L	PF17.07
3	Fixed adapter	PF17.06
4	10mm brush	PF17.13
5	Kit corridor frame	PF17.21
6	Screws	-

Schema di montaggio vetri

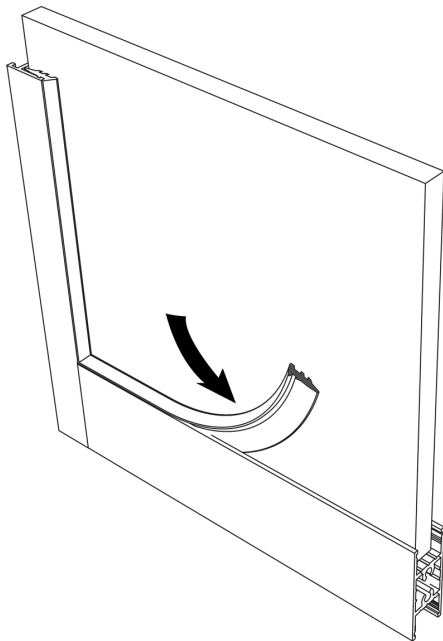

TWENTY series match with glass from 6 to 12 mm of thickness

Glass are fixed in two different ways:

- internal and external gasket
- external gasket and a layer of silicone sealant in the internal side

It is necessary to use different dimension of gaskets to adapt the profile to glasses with various thickness.

For different assembly layout refer to the diagram below.

**For a right assembly:**

- 1- place the spacers in the profiles (*2/3/4mm spacers supplied*).
- 2- match the external profile and the glass and fixed them as shown in the assembly scheme "A" (*pag.9*).
- 3- Cut and fit the external gasket along the wing frame perimeter.
- 4- Cut and press the internal gasket and fit it in the correct position

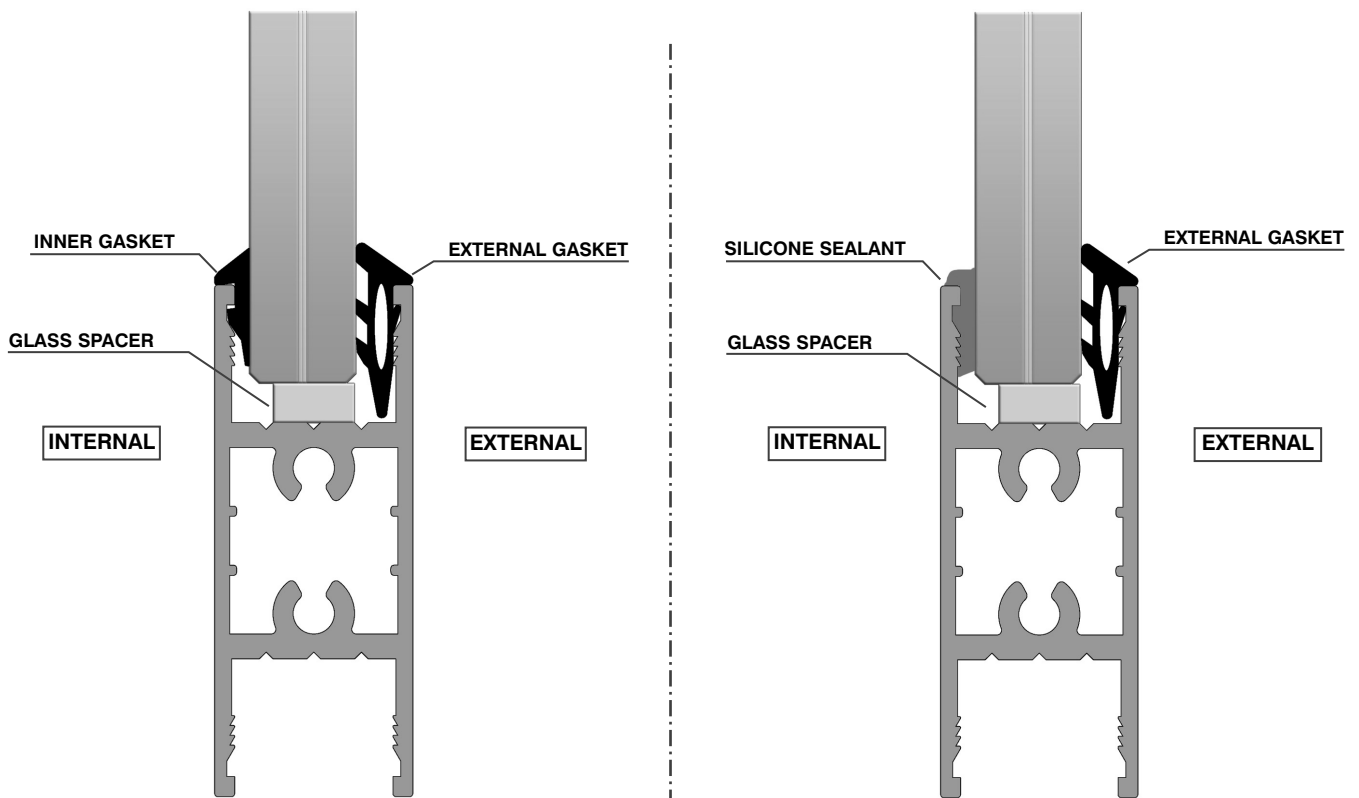

V	double gasket		gasket + silicone sealant	
	internal side	external side	internal side	external side
3+3	PF 03.29 - gasket panestop type2	PF 17.15 - type A gasket	-	-
4+4	PF 13.10 - gasket panestop type6	PF 17.15 - type A gasket	silicone	PF 17.15 - tipe A gasket
5+5	PF 13.10 - gasket panestop type6	PF 03.34 - gasket panestop type9	silicone	PF 13.08 - gasket panestop type3
6+6	PF 13.10 - gasket panestop type6	PF 03.29 - gasket panestop type2	silicone	PF 03.34 - gasket panestop type9
6	PF 03.29 - gasket panestop type2	PF 17.15 - type A gasket	-	-
8	PF 13.10 - gasket panestop type6	PF 17.15 - type A gasket	-	-
10	PF 13.10 - gasket panestop type6	PF 13.08 - gasket panestop type3	silicone	PF 17.15 - tipe A gasket
12	PF 13.10 - gasket panestop type6	PF 03.29 - gasket panestop type2	silicone	PF 03.34 - gasket panestop type9

# **TWENTY**

Aluminium profiles for doors and windows



**SESAMO srl**

Str. Gabannone, 8/10 • 15030 Terruggia (AL) • Italy

Tel: +39 0142 403223 • Fax: +39 0142 403256

[www.sesamo.eu](http://www.sesamo.eu) • E-mail: [info@sesamo.eu](mailto:info@sesamo.eu)