



# MAGNUM

Aluminium profiles for doors and windows

I  
N  
S  
T  
A  
L  
L  
A  
T  
I  
O  
N  
M  
A  
N  
U  
A  
L



Organizzazione con Sistema  
di Gestione certificato  
Company with Management  
System certified

ISO 9001:2000





# CERTIFICATE

**The Certification Body TÜV Rheinland Italia S.r.l.**  
certifies, in accordance with the TÜV Rheinland Group procedures, that the Company

**SESAMO S.r.l.**  
**Strada Gabannone, 8/10**  
**I - 15030 Terruggia (AL)**



has established and applies a quality management system  
for the following scope:

**Design, manufacturing and assistance  
of automatic entrance devices. EA 17, 18**

Through an Audit, Report No. 1130610, proof has been furnished that the  
quality management system fulfils the requirements of the standard

**UNI EN ISO 9001:2008**

Please refer to the Quality Manual for the details about  
the exclusions with respect to the requirements of the standard.

Certificate Registration No. **39 00 1130610**.

This Certificate is valid from 2011-08-20 to 2014-07-15.

The reference date for all the next audits is (day-month): 04-06.

**Milan, 2011-08-20. First Certification: 2006-10-17**

The certification responsible  
TÜV Rheinland Italia S.r.l., Via E. Mattei, 10 - I - 20010 Pogliano Milanese (MI)



SGQ N° 083A  
Membro degli Accordi di  
Mutuo Riconoscimento EA, IAF e ILAC  
Signatory of EA, IAF and ILAC  
Mutual Recognition Agreements

www.tuvitalia.com



## Contents

Introduction .....	pag. 3
Presentation .....	pag. 4
Labprofiles .....	pag. 4
Purpose and use of the manual .....	pag. 4
Profile working .....	pag. 5
MAGNUM series.....	pag. 6
Wing diagrams .....	pag. 7
Sliding wing .....	pag. 7
Fixed wing .....	pag. 7
Fixed wing with fascia .....	pag. 7
Semi-fixed wing .....	pag. 8
Sliding wing with ARIETE .....	pag. 8
Standard frame .....	pag. 9
Frame with fascia .....	pag. 9
Antipanic frame .....	pag. 9
Standard frame with transom-window .....	pag. 10
Antipanic frame with transom-window .....	pag. 10
Accessory profiles .....	pag. 10
Assembly diagrams .....	pag. 11
Sliding wing positioning .....	pag. 18
Glass pane assembly diagram .....	pag. 18

## Introduction

We would like to thank you for choosing this product.

In order to optimize the assembly and installation of the MAGNUM profiles, the Sesamo Company recommends that you read and carefully follow the installation and use instructions provided in this manual. The installation must be performed only by professionally qualified personnel for whom this manual has been written. Any errors during the installation phase may be the source of danger for people or things. The packaging materials (wood, plastic, cardboard, etc.) should not be discarded in the environment or left within reach of children since they are potential sources of danger. Every individual installation phase must be performed in conformity with current regulations and according to Good Practice principles. Ensure, before beginning the installation, that the product is complete and has not been damaged during transport or as a result of improper storage. Before installing the product ensure that each architectonic and structural element of the entrance is suitable and sufficiently sturdy to be automated. Conduct a careful analysis of the risks and make appropriate modifications to eliminate the areas of dragging, crushing, shearing and other generally dangerous areas. SESAMO is not responsible for any non-compliance with "good practice" or specific regulations during the construction of the frame to be motorized. All the protective safety devices of the automatic door (photocells, active sensors, etc.) must be installed in conformity with the regulations and directives in force, the analysis of the risks carried out, the typology of the system, the use, the traffic, the forces and inertia in play. Always pay particular attention to the zones where the following may occur: crushing, shearing, dragging and any other danger in general, placing appropriate signs as needed.

Use only original spare parts in the maintenance or repair operations.

The MAGNUM profiles have been designed for the realization of automatic entrances and are also available with antipanic systems. Any other use will be considered contrary to the use foreseen by the manufacturer who, consequently, cannot be held liable.

## Presentation

MAGNUM is the line of aluminium door and window profiles with increased section designed by SESAMO with the idea of satisfying the greatest possible number of architectural solutions.

The MAGNUM line is among the most complete on the market of aluminium profiles for automatic sliding doors, allowing to realize all the components an automatic sliding entrance: sliding wings, fixed wings, ground guides, transom-window, automation support beams and interfaces with fixed elements such as walls.

The new design of the rounded forms confers harmony and importance to the structures realized with these profiles.

Particular solutions and specific accessories ensure an elevated simplicity in the assembly and installation, guaranteeing total compatibility with SESAMO automatism.

The doors realized with MAGNUM profiles can be equipped with the ARIETE breakaway antipanic system to produce emergency exits for public or private areas.

With MAGNUM, the SESAMO customers will have a real and complete tool available for the realization of "turnkey" finished systems.

## Labprofiles



A unique instrument that SESAMO makes available to its customers is the LABPROFILES software, completely free and downloadable from the site [www.seasamo.eu](http://www.seasamo.eu). LABPROFILES allows to generate the vertical and horizontal sections, the components list, accessories list and cut list in order to realize a complete sliding system.

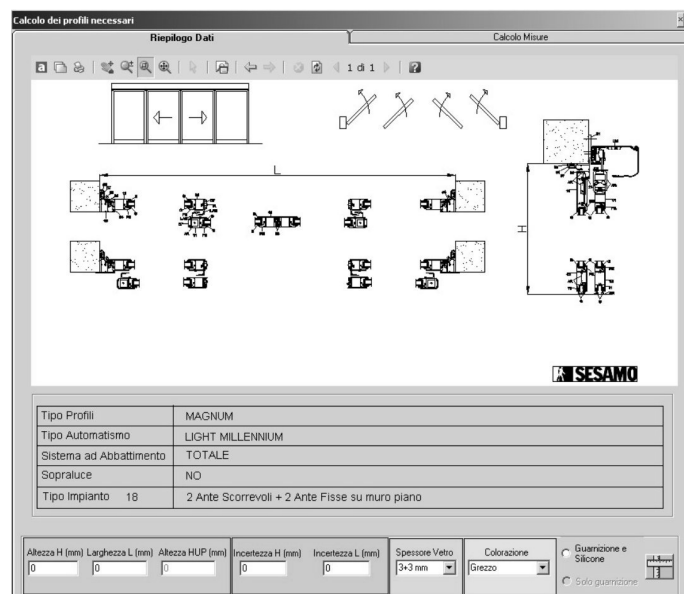

The insight of the menu, the detailed graphics, the possibility to make blowups and printouts of the profiles in order to highlight the nodes and the labels on the individual components represented in the pictures guarantee a very intuitive and immediate use without requiring particular computer knowledge.

LABPROFILES includes a large variety of predetermined solutions, personalizable by the user. It is however possible to realize entrances different from those predetermined thanks to the software flexibility.

## Purpose and use of the manual

This manual is complementary to LABPROFILES to which it refers for information necessary for the choice, cut and working of the profiles and their completion with the relative accessories; it is subdivided into three main sections.

The first in which the MAGNUM series is presented graphically, showing the characteristic dimensions and the equipment necessary for its working.

The second section in which the essential elements of an automatic entrance (sliding wing, fixed wing, etc.) are schematized and the constituent components are highlighted with reference to the relative assembly diagram.

The third section concerns the assembly of the various elements.

Profile working

The equipment necessary for the working of the MAGNUM series aluminium profiles is composed of:

- Cutting machine:** circular sawing machine capable of cutting at intermediate degrees (-45°/90°/+45°) and able to obtain burr-free cuts and perfect cutting angles in order to enable profile coupling.
- End-facing machine:** milling machine equipped with a cutter unit suitable for milling the ends of certain profiles, shown in the following figures, allowing for their precise coupling with other profiles.
- Drilling machine.**
- Punch press:** Realizes the working necessary for the positioning of the angular junction brackets.

Working for insertion of 45° angle brackets

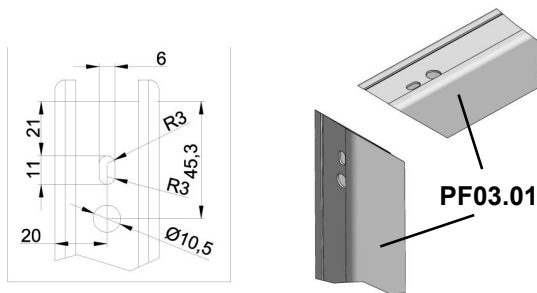

Ariete sliding wing vertical upright profile

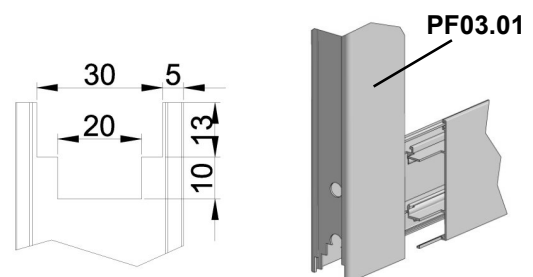

Fixed wing upright profile

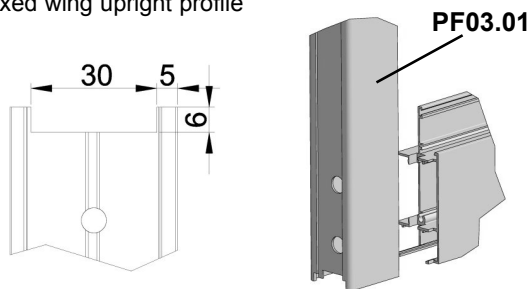

Ariete sliding wing horizontal stile profile

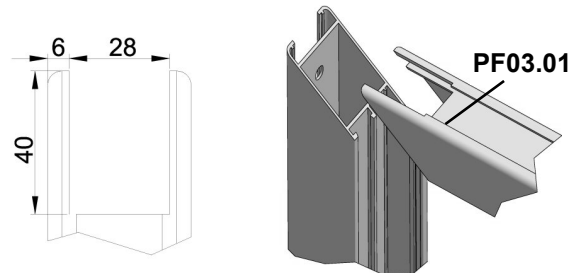

Sliding wing upright profile

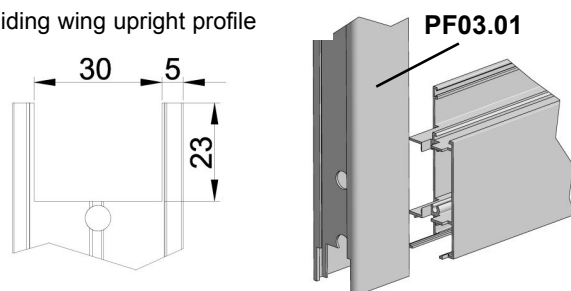

Semi-fixed wing with transom-window

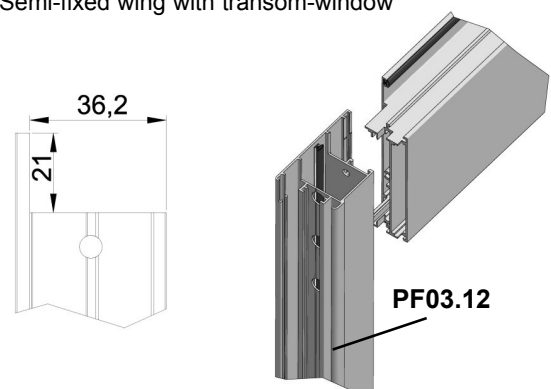

Lower crossbeam

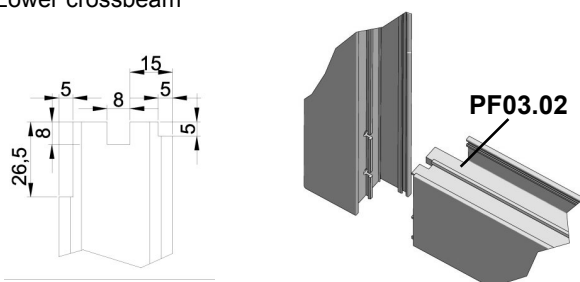

MAGNUM series profiles list

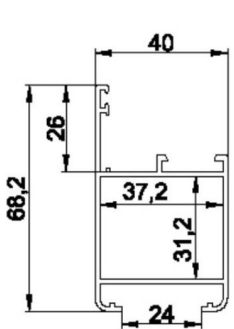

PF03.01  
Peso 0,840kg/m

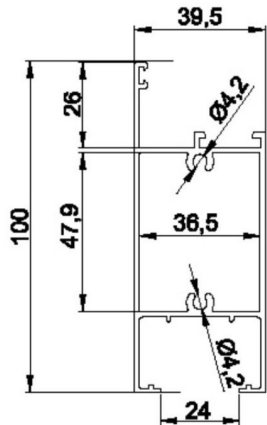

PF03.02  
Peso 1,276kg/m

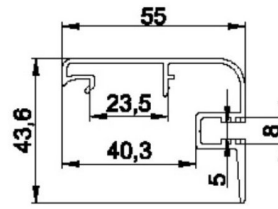

PF03.05  
Peso 0,624kg/m

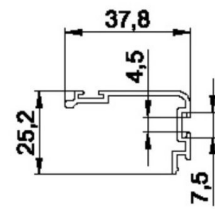

PF03.06  
Peso 0,384kg/m

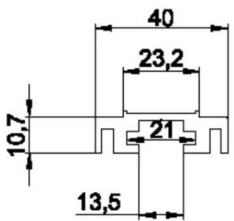

PF03.03  
Peso 0,660kg/m

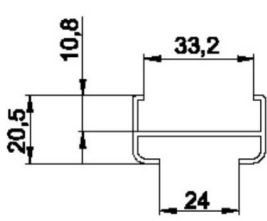

PF03.04  
Peso 0,384kg/m

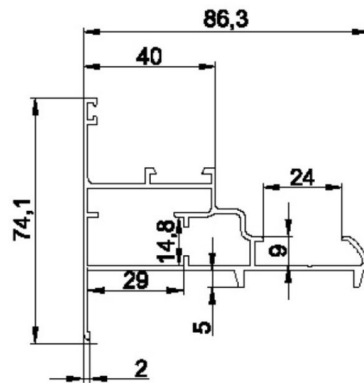

PF03.08  
Peso 1,162kg/m

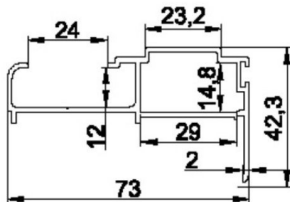

PF03.09  
Peso 0,846kg/m

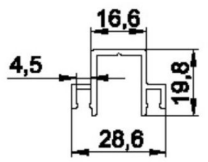

PF03.11  
Peso 0,316kg/m

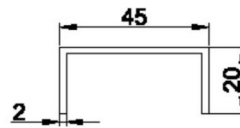

PF03.17  
Peso 0,439 kg/m

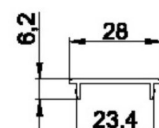

PF03.07  
Peso 0,128kg/m

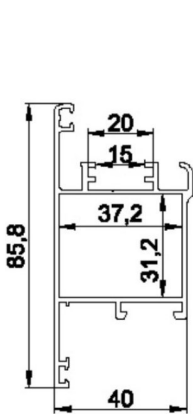

PF03.12  
Peso 1,016kg/m

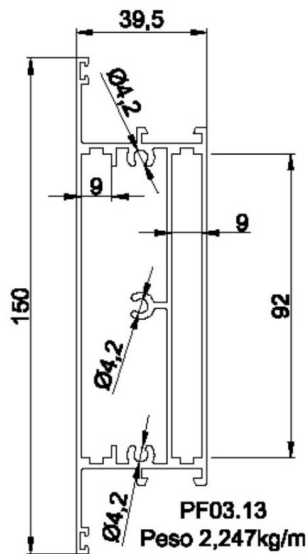

PF03.13  
Peso 2,247kg/m

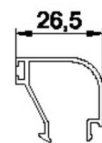

PF03.16  
Peso 0,284kg/m

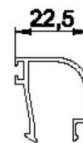

PF03.15  
Peso 0,266kg/m

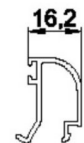

PF03.14  
Peso 0,274kg/m

PF03.01	Sliding wing upright
PF03.02	Sliding wing lower crossbeam
PF03.03	Automatism adapter
PF03.04	False upright on wall
PF03.05	Air seal labyrinth
PF03.06	Transom-window closure plate
PF03.07	Upright caps
PF03.08	Breakaway frame
PF03.09	Standard frame
PF03.11	Sliding wing guide
PF03.12	Breakaway upright
PF03.13	Profile for transom-window
PF03.14	11 mm Glass stop
PF03.15	16 mm Glass stop
PF03.16	22 mm Glass stop
PF03.17	45x20x2 mm "U"

Wing diagrams

Sliding wing

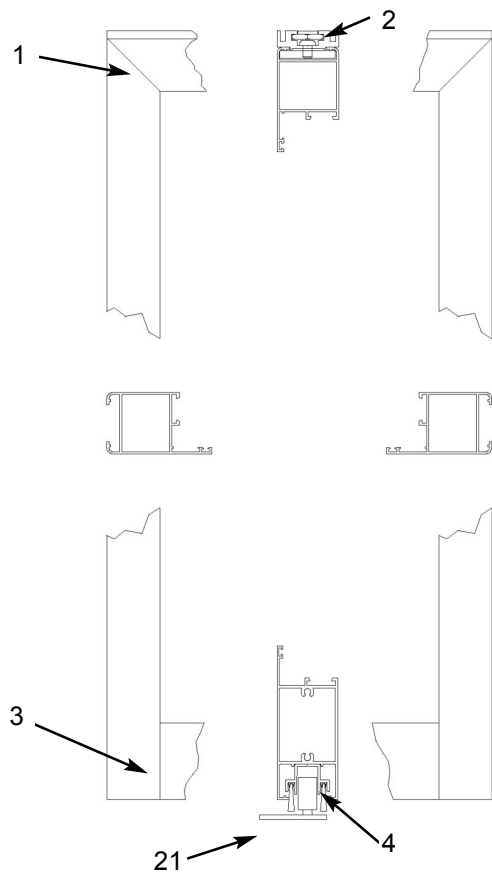

Fixed wing

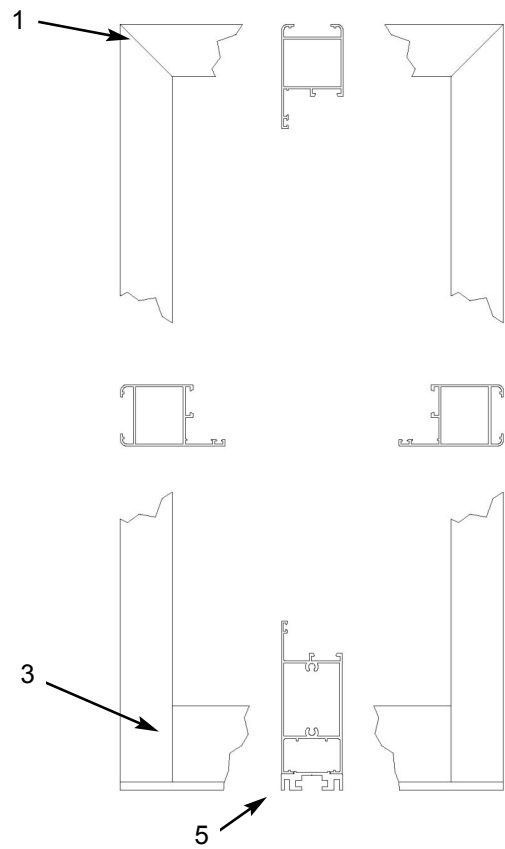

Fixed wing with fascia

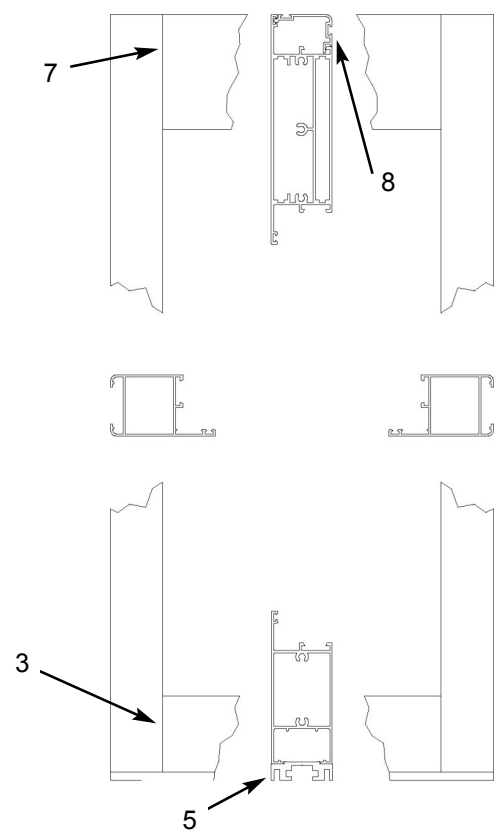

Assembly diagram	Page
n° 1	11
n° 2	11
n° 3	12
n° 4	12
n° 5	12
n° 7	13
n° 8	13
n° 21	18

The profiles can be completed by following assembly diagram n. 6 on page 13.

**Semi-fixed wing**

**Sliding wing with ARIETE**

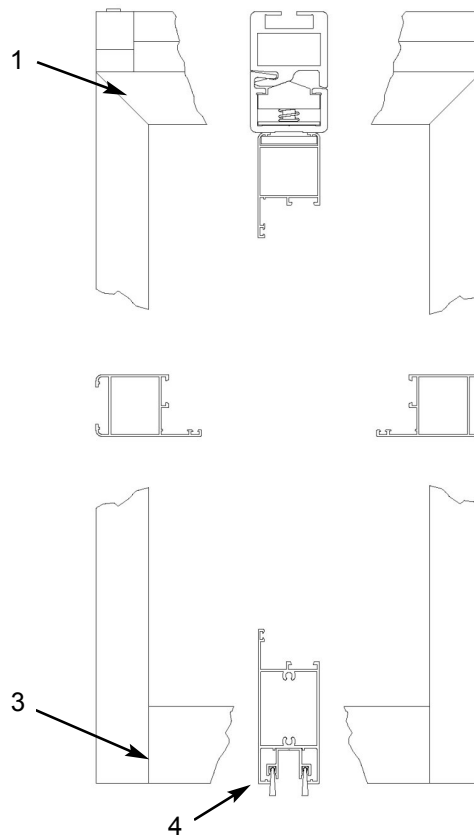
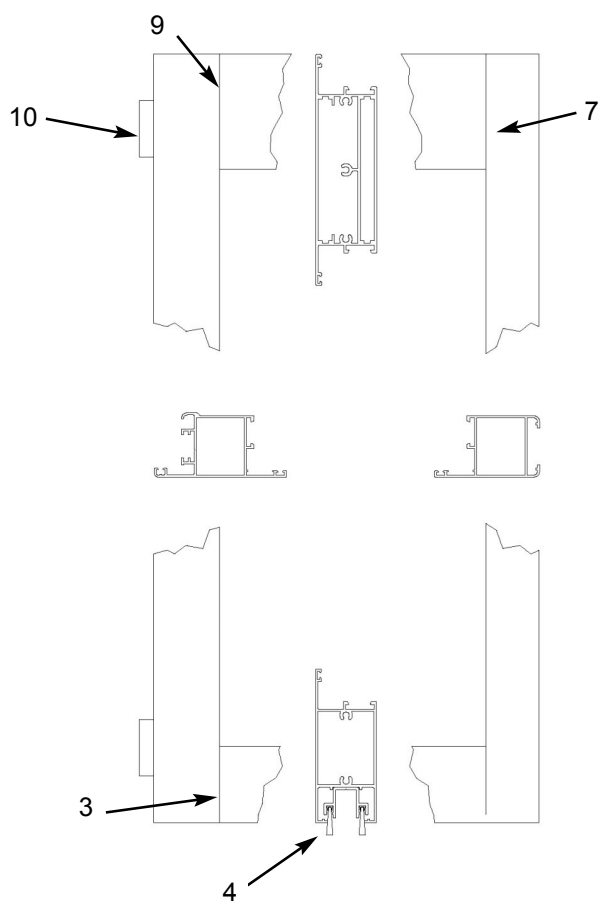

Assembly diagram	Page
n° 1	11
n° 3	12
n° 4	12
n° 7	13
n° 9	14
n° 10	14

The profiles can be completed by following assembly diagram n. 6 on page 13.

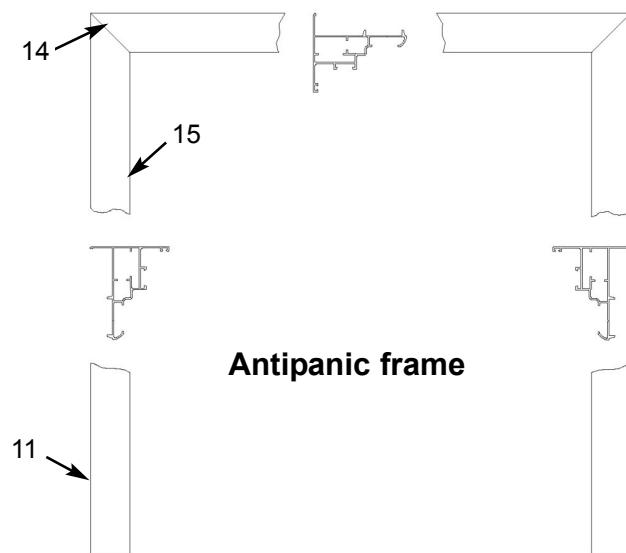
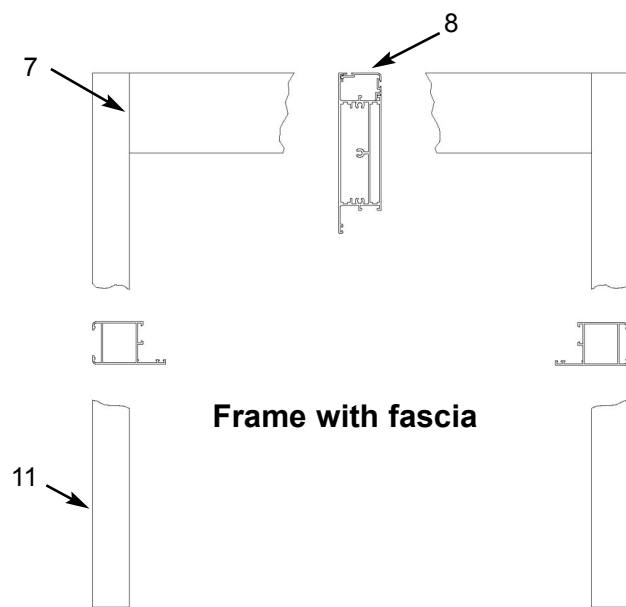
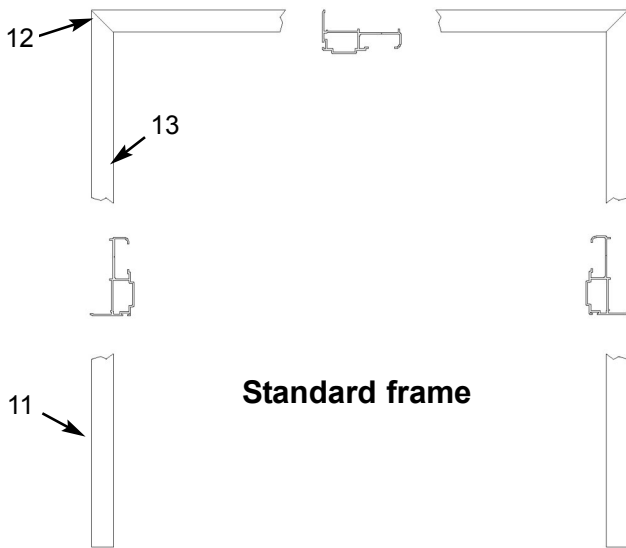

Assembly diagram	Page
n° 7	13
n° 8	13
n° 11	15
n° 12	15
n° 13	16
n° 14	16
n° 15	16

The profiles can be completed by following assembly diagram n. 6 on page 13.

**Standard frame with transom-window**

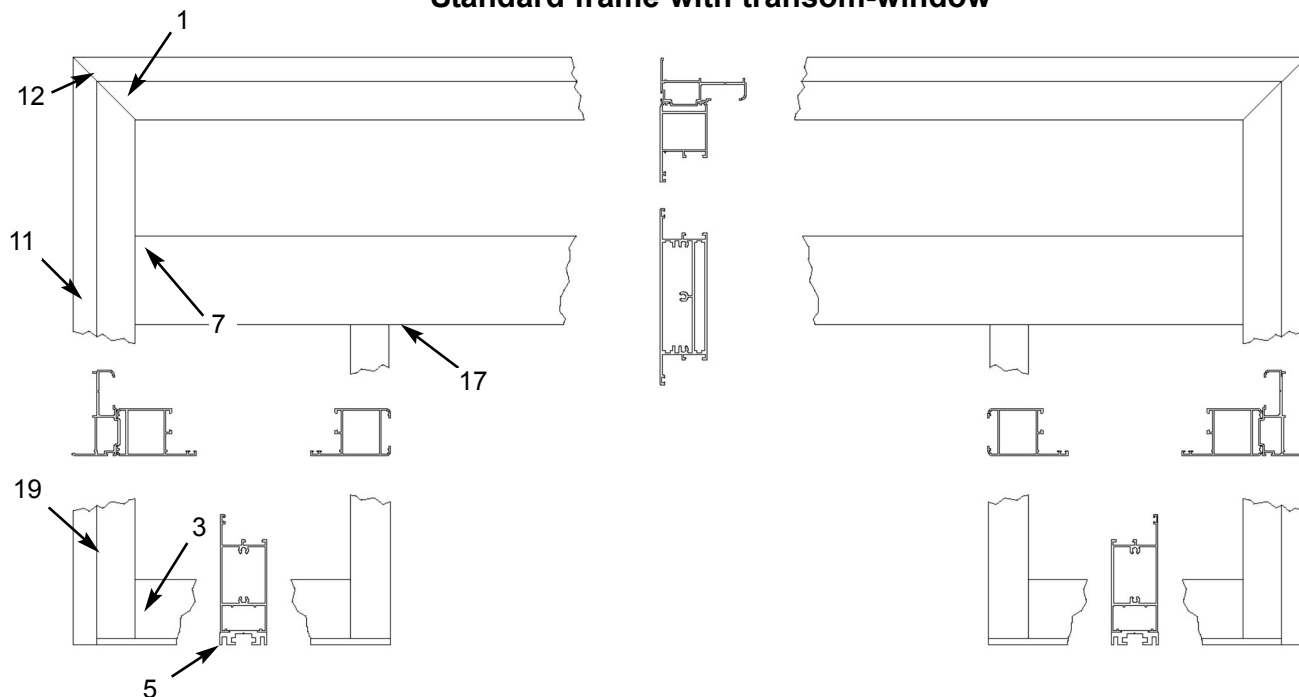

Assembly diagram	Page
n° 1	11
n° 3	12
n° 5	12
n° 7	13
n° 11	15
n° 12	15
n° 14	16
n° 15	16
n° 16	16
n° 17	17
n° 18	17
n° 19	17
n° 20	17

**Antipanic frame with transom-window**

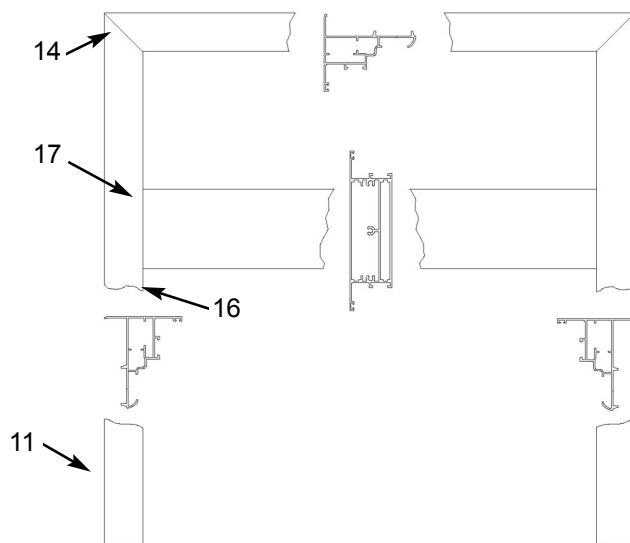

**Accessory profiles**

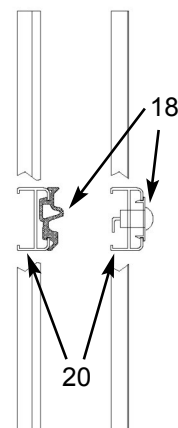

The profiles can be completed by following assembly diagram n. 6 on page 13.

## Assembly diagrams

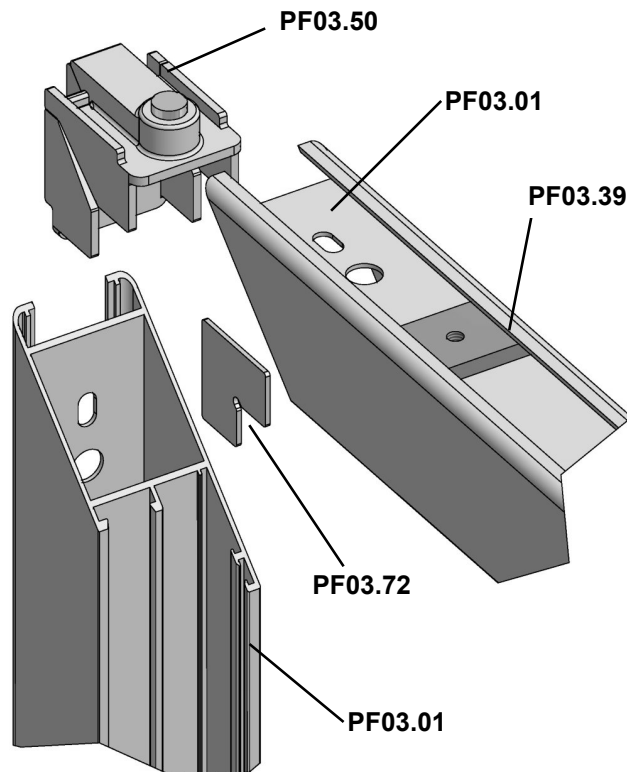

### Assembly diagram 1

Insert part **PF03.72** and part **PF03.50**, by unscrewing the operating screw, into the special seats of one of the profiles **PF03.01**.

Slide the second profile **PF03.01** until it couples with part **PF03.50**. Tighten the operating screw through one of the slots until the assembly of the two aluminium profiles is solid.



#### CAUTION

Before closing the second angle at 45° proceed to the insertion of the plates **PF03.39** as shown in assembly diagram 2.

### Assembly diagram 2

Insert as many plates **PF03.39** inside profile **PF03.01** as there are holes on profile **PF03.03**.

Rest profile **PF03.03** on profile **PF03.01** and, lining up the holes with the previously inserted plates, screw them on with the appropriate screws **PF03.76** so as to fasten the two profiles together.

Insert the parts **PF03.40** that will subsequently be used for fastening the automatism carriages with screws **PF03.75**.

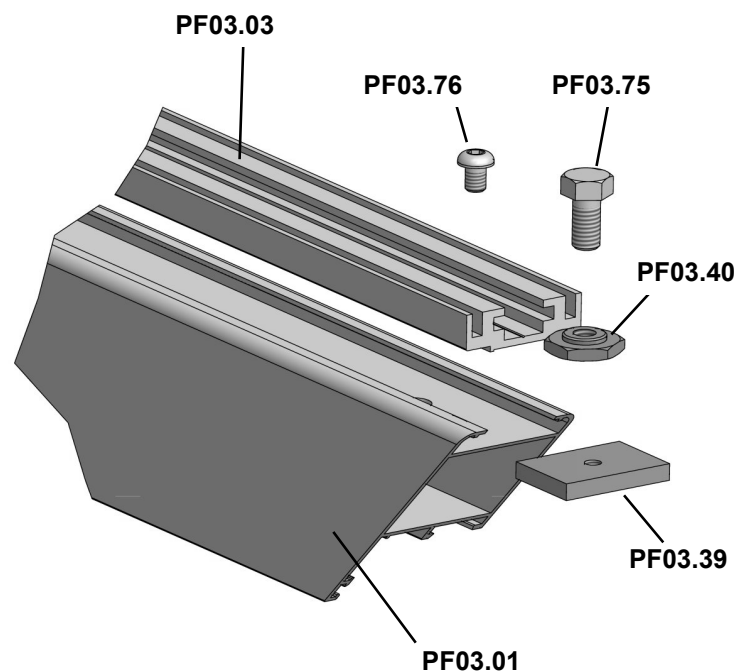

### Assembly diagram 3

Place profile **PF03.01** beside profile **PF03.02**. Insert the screws **PF03.77** into the special holes on profile **PF03.01** and screw them on so as to render the assembly of the two aluminium profiles solid.

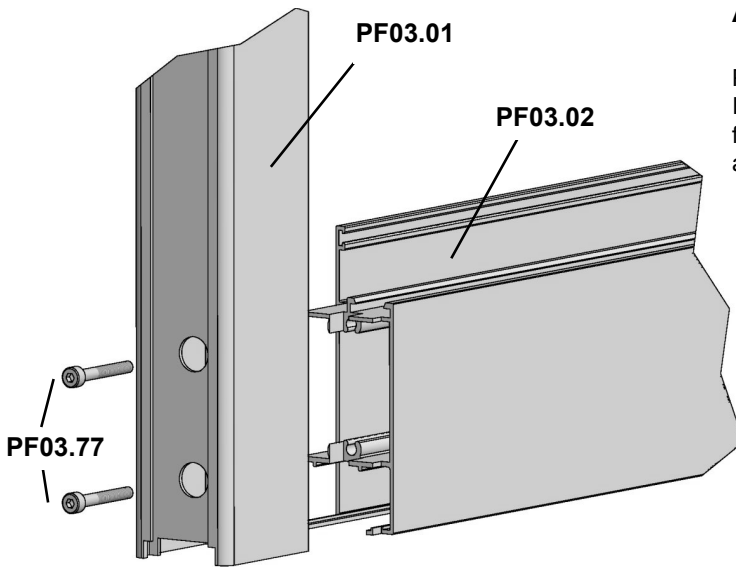

### Assembly diagram 4

Insert the two small brushes **PF01.47** inside the two seats of profile **PF03.11** and carefully block them. Insert profile **PF03.11** inside profile **PF03.02**, positioning it in the centre of profile **PF03.02**, and screw it on with one **PF03.79** screw every 20cm.

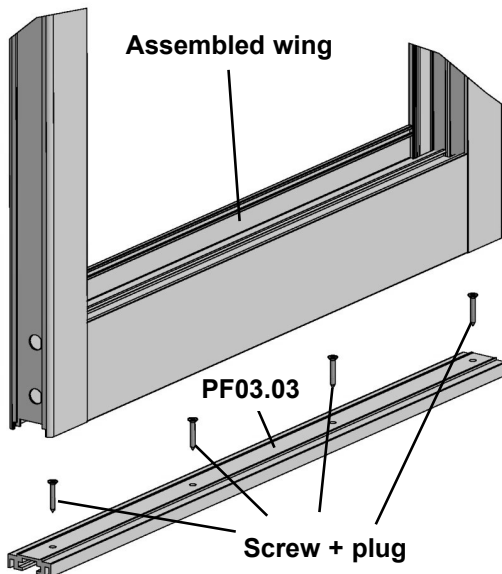
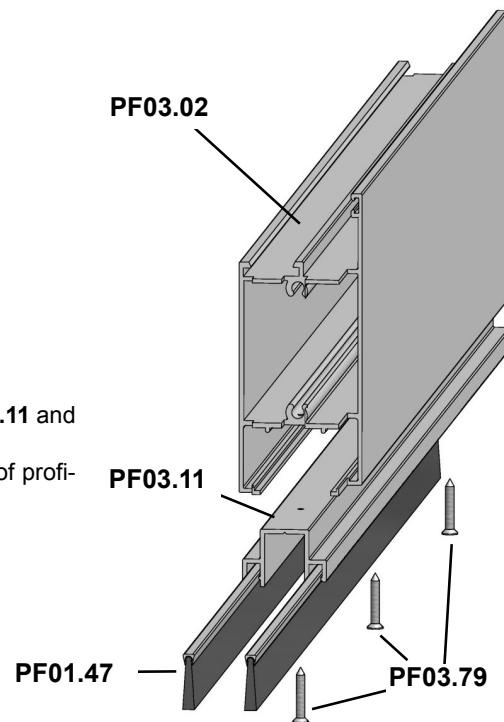

### Assembly diagram 5

Providing for a fastening point every 20cm, screw profile **PF03.03** onto the floor with the screws and plugs chosen according to the floor type. Slip the previously assembled fixed wing over profile **PF03.03**.

### Assembly diagram 6

**A:** Mount profile **PF03.05**, making it snap onto **PF03.01**; bore the two profiles and unite them with screws **PF03.79**. Insert the brush **PF03.27** into the special seat.

**B:** Mount profile **PF03.07**, making it snap onto **PF03.01**, make the assembly more solid if necessary by slightly deforming the fins of **PF03.07** or by spreading a thin layer of silicone sealant.

**C:** Press the gasket **PF03.28** onto profile **PF03.01**.

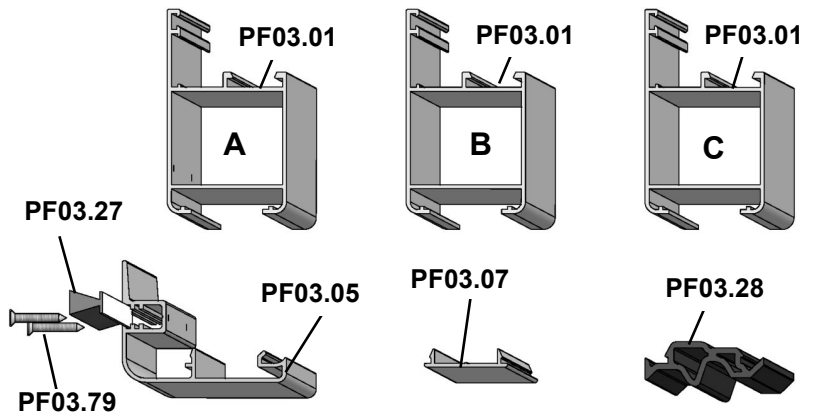

### Assembly diagram 7

Place profile **PF03.01** beside profile **PF03.13**. Insert the screws **PF03.77** into the special holes on profile **PF03.01** and screw them on so as to render the assembly of the two aluminium profiles solid.

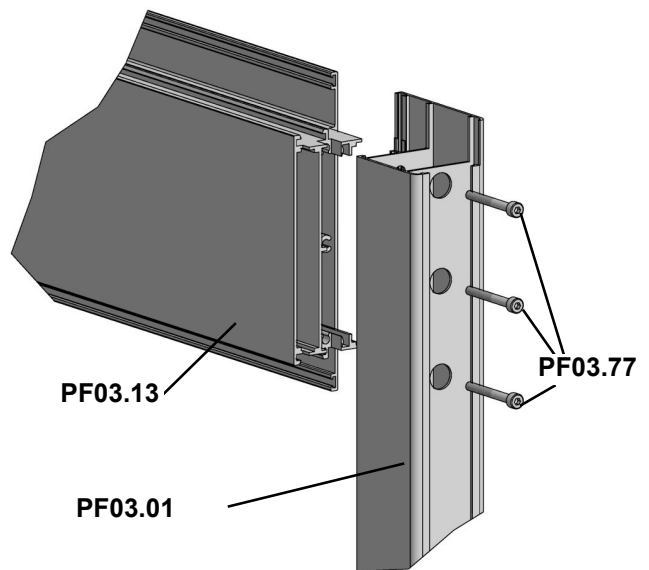

### Assembly diagram 8

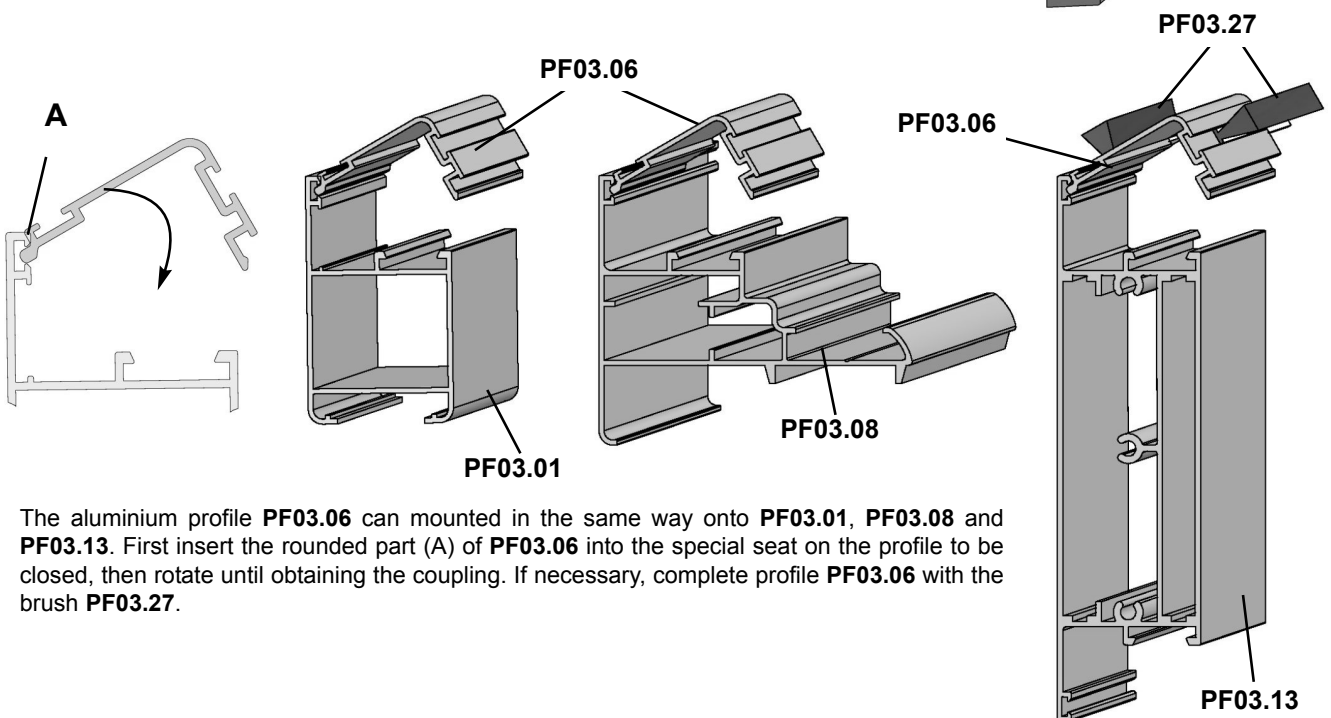

The aluminium profile **PF03.06** can be mounted in the same way onto **PF03.01**, **PF03.08** and **PF03.13**. First insert the rounded part (A) of **PF03.06** into the special seat on the profile to be closed, then rotate until obtaining the coupling. If necessary, complete profile **PF03.06** with the brush **PF03.27**.

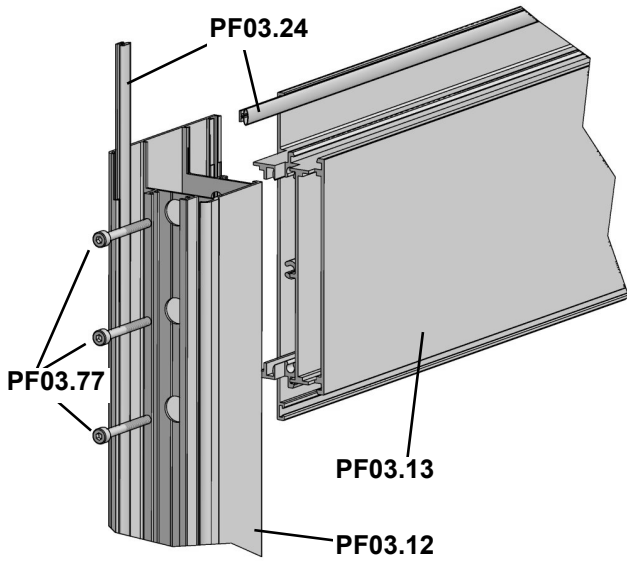

### Assembly diagram 9

Place profile **PF03.12** beside profile **PF03.13**. Insert the screws **PF03.77** into the special holes on profile **PF03.12** and screw them on so as to render the assembly of the two aluminium profiles solid. Complete the assembly by introducing the gasket **PF03.24** into the special seats of the two aluminium profiles.

### Assembly diagram 10

Disassemble the hinge **PF03.53/54** into parts **A** and **B**. Mount part **A** onto the aluminium profile **PF03.12** (semi-fixed wing upright) choosing a temporary position; mount part **B** on the corresponding profile **PF03.01** or **PF03.08** in a temporary position. Slide part **A** and part **B** in the special raceways until obtaining the desired position (approximately at the ends of the aluminium profiles), tighten the screws with metric thread and, after having checked the positioning, complete the assembly by making a 2.5 mm-diameter hole through the central hole of parts **A** and **B** and screwing in the special self-threading screw. It is necessary to mount 2 hinges per wing, but if the wing is very heavy it is best to mount a third hinge.

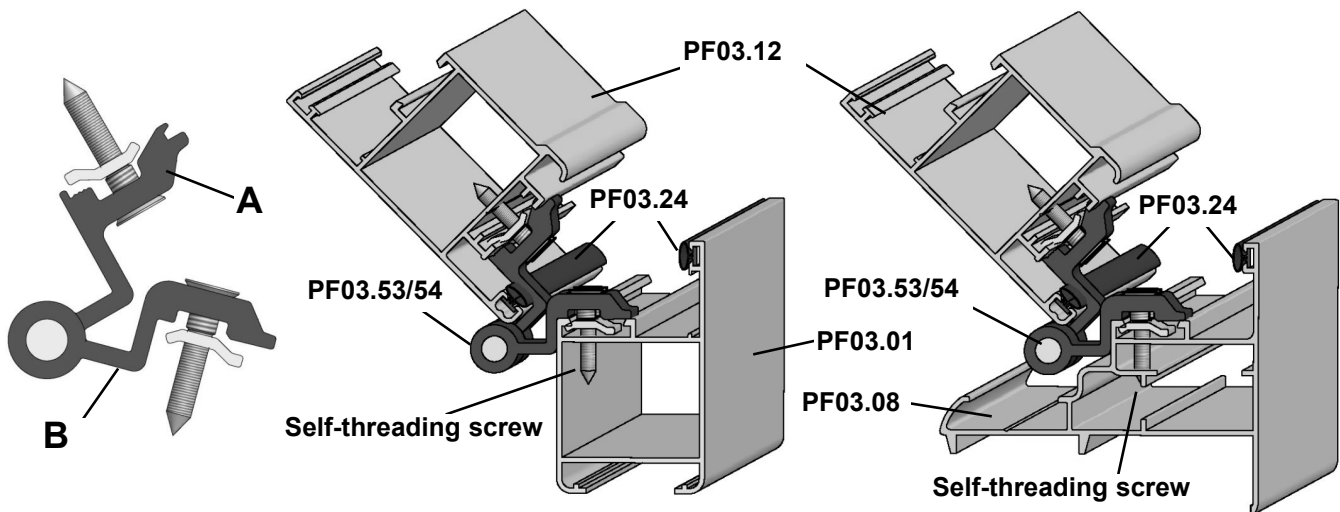

### Assembly diagram 11

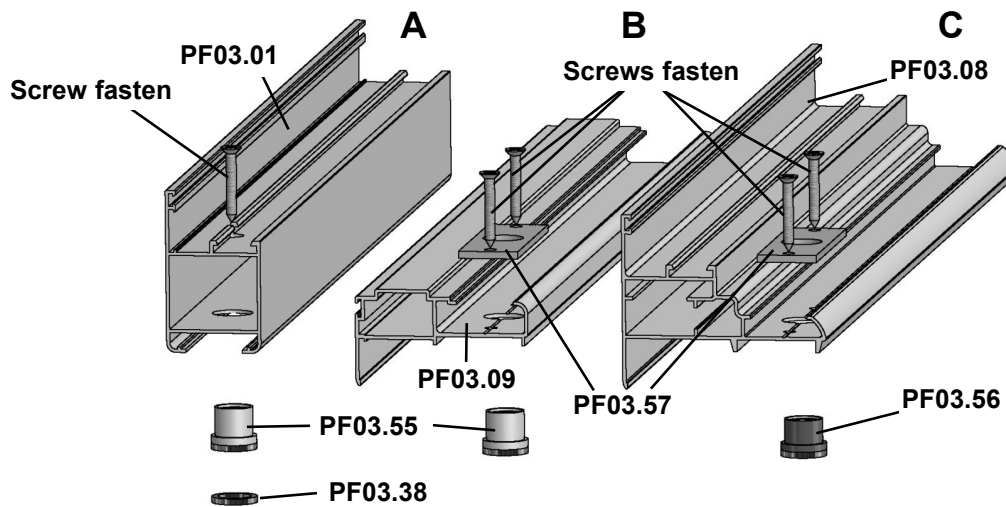

- A** Bore **PF03.01** using the **PF03.59** tip, insert the spacers **PF03.55** and screw them onto the aluminium profile with the spanner **PF03.58**; mount the part **PF03.38** making it snap onto **PF03.55**. Adjust **PF03.55** with the spanner **PF03.58**, offsetting the imperfections of the wall. Choose screws that are suitable for the type of support on which to fasten the aluminium profile, introducing them in the cavity of **PF03.55** and screwing them in.
- B** Bore **PF03.09** using the **PF03.59** tip, insert the spacers **PF03.55** and screw them onto the aluminium profile with the spanner **PF03.58**. Adjust **PF03.55** with the spanner **PF03.58**, offsetting the imperfections of the wall. Choose screws that are suitable for the type of support on which to fasten the aluminium profile, screw them in using the plate **PF03.57** (2 screws per spacer).
- C** Bore **PF03.08** using the **PF03.59** tip, insert the spacers **PF03.56** and screw them onto the aluminium profile with the spanner **PF03.58**. Adjust **PF03.56** with the spanner **PF03.58**, offsetting the imperfections of the wall. Choose screws that are suitable for the type of support on which to fasten the aluminium profile, screw them in using the plate **PF03.57** (2 screws per spacer).

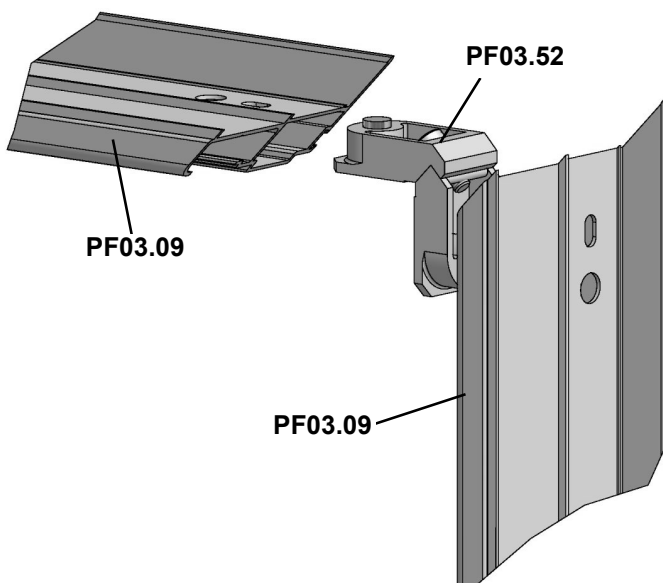

### Assembly diagram 12

Insert part **PF03.52**, by unscrewing the operating screw, into the special seats of one of the profiles **PF03.09**. Slide the second profile **PF03.09** until it couples with part **PF03.52**. Tighten the operating screw through one of the slots until the assembly of the two aluminium profiles is solid.

### Assembly diagram 13

Insert the brush **PF03.27** into the special seat of profile **PF03.09**. Mount profile **PF03.07**, making it snap onto **PF03.09**, make the assembly more solid if necessary by slightly deforming the fins of **PF03.07** or by spreading a thin layer of silicone sealant.

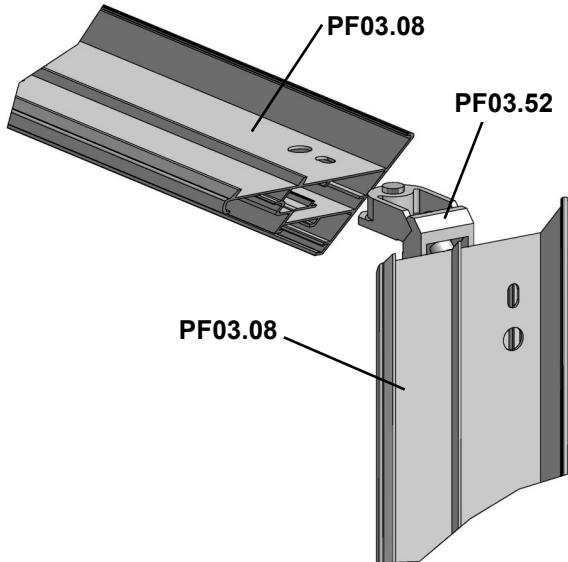
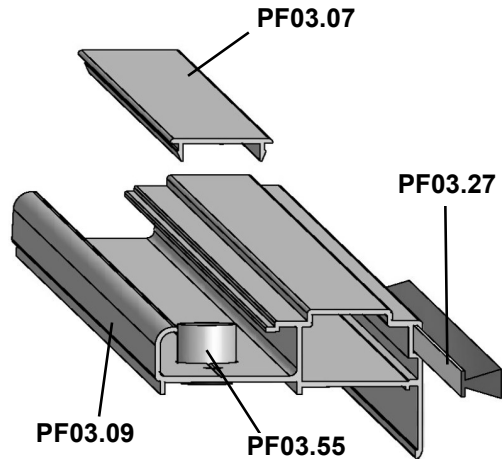

### Assembly diagram 14

Insert part **PF03.52**, by unscrewing the operating screw, into the special seats of one of the profiles **PF03.08**. Slide the second profile **PF03.08** until it couples with part **PF03.52**. Tighten the operating screw through one of the slots until the assembly of the two aluminium profiles is solid.

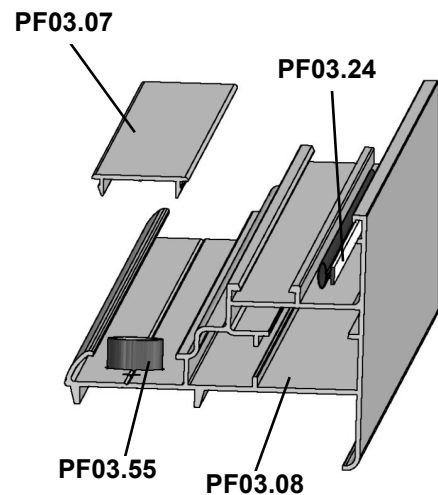

### Assembly diagram 15

Insert the gasket **PF03.24** into the special seat of profile **PF03.08**. Mount profile **PF03.07**, making it snap onto **PF03.08**, make the assembly more solid if necessary by slightly deforming the fins of **PF03.07** or by spreading a thin layer of silicone sealant.

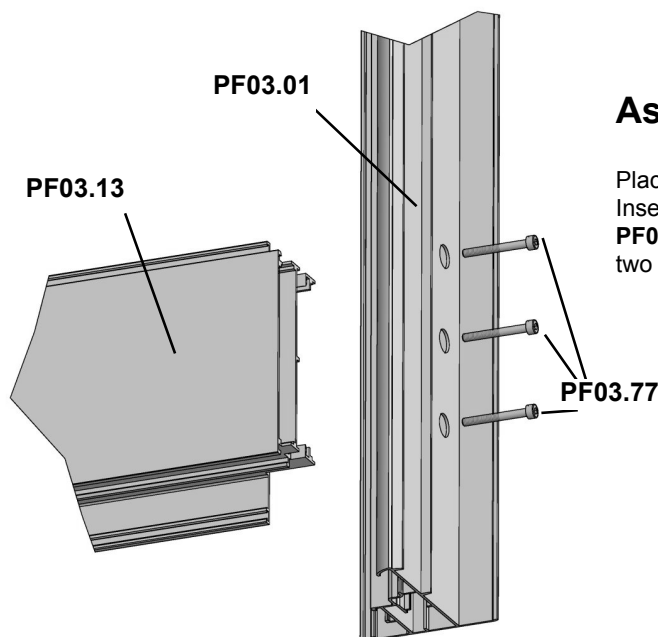

### Assembly diagram 16

Place profile **PF03.01** beside profile **PF03.13**. Insert the screws **PF03.77** into the special holes on profile **PF03.01** and screw them on so as to render the assembly of the two aluminium profiles solid.

### Assembly diagram 17

Introduce two parts **PF03.49** into the special seats on the aluminium profile **PF03.01**. Move **PF03.01** into position, making 2 holes with diameter of 2.5mm on **PF03.13**, centre the holes resting **PF03.49** on the aluminium profile. Screw on the screws until the assembly is solid.

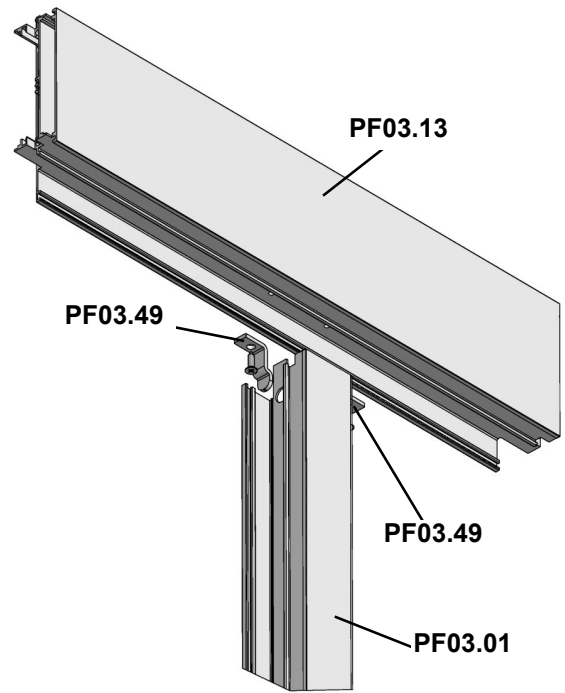
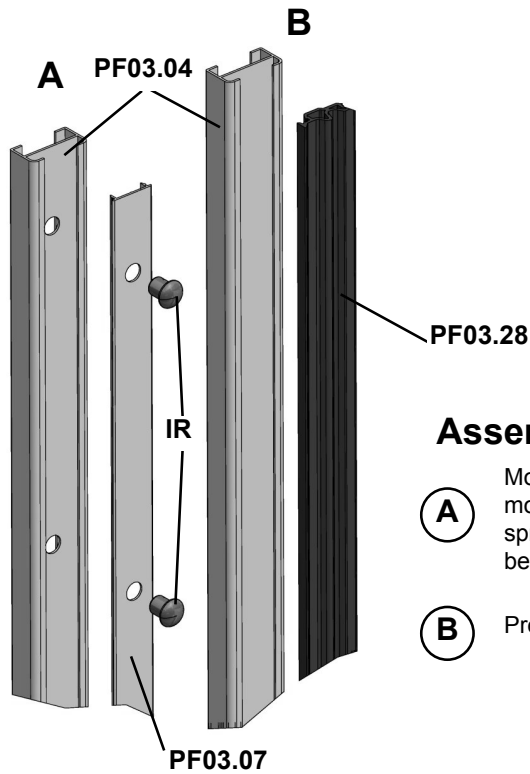

### Assembly diagram 18



Mount profile **PF03.07**, making it snap onto **PF03.09**, make the assembly more solid if necessary by slightly deforming the fins of **PF03.07** or by spreading a thin layer of silicone sealant. For the fastening of the photocell beams, refer to the relative manual.



Press the gasket **PF03.28** onto the aluminium profile **PF03.04**.

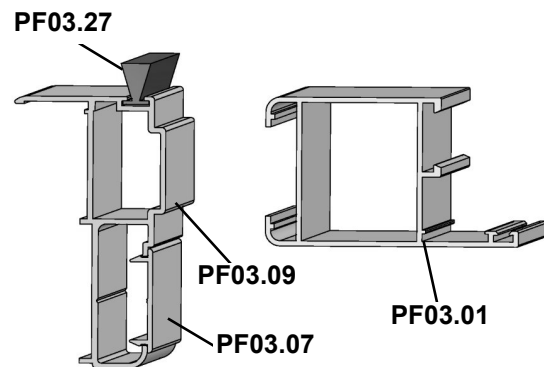

### Assembly diagram 19

Place and constrain profile **PF03.01** against profile **PF03.09**.

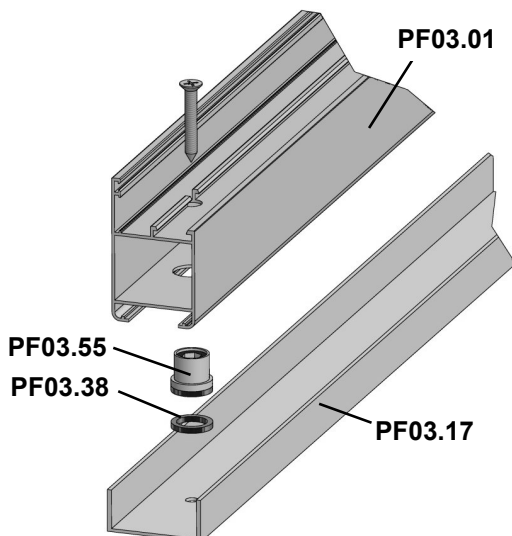

### Assembly diagram 20

Use profile **PF03.17** to offset any irregularities of the wall on which the door is positioned. Profile **PF03.01** is prepared for assembly as shown in assembly diagram n.11. In correspondence with the central hole of part **PF03.55**, make a hole with a diameter of 6mm. Introduce profile **PF03.01** into profile **PF03.17**; rest the latter against the wall and adjust **PF03.55** as indicated in diagram 11 so as to obtain perfect perpendicularity of **PF03.01**. Fasten to the wall using means suited to the type of structure.

Sliding wing positioning

Assembly diagram 21

Adjust the height of the sliding wing so that it is approximately 13mm along the entire run.

Move the wing into the closed position, slip the sliding block into the special seat and set out the position of the ground guide PF03.70 referring to the diagram in the figure. Fasten to the floor with a 6mm plug at the central hole of the plate. The two fastening holes allow to perform a slight adjustment of the position of the sliding block axis by rotating the plate around the axis of the central hole. When the ideal position has been obtained, mark the centre of the hole for the second plug and fasten it.

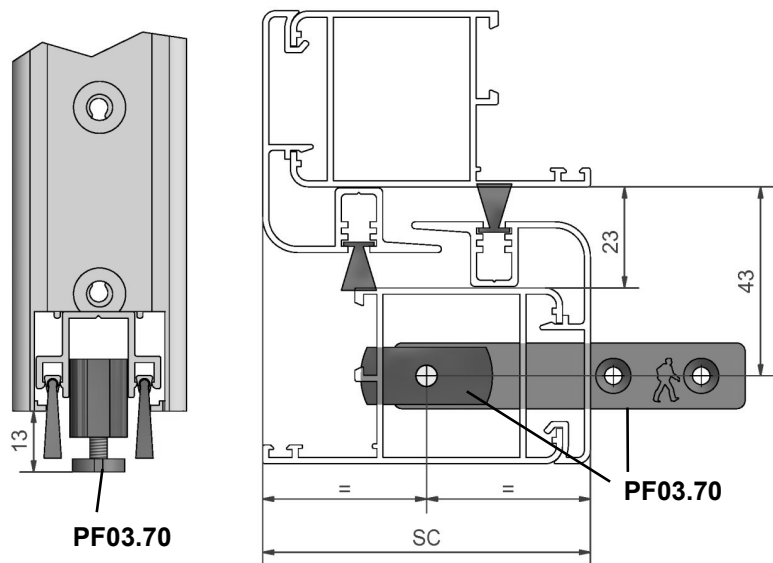

Glass pane assembly diagram

It is possible to install glass panes of variable thickness by combining different gaskets **G** with 3 types of glass stop profiles **FE**. As an example, the assembly of the glass pane onto profile **PF03.01** is illustrated. The instructions remain valid for all profiles that can contain a pane.

- A** Insert the gasket **PF03.30** into the special seat of profile **PF03.01**. Position the spacers **D** (thickness 11mm) on which the glass pane then rests in order to obtain an interpenetration, glass pane/aluminium profile, of 15mm. Mount the glass stop profile **FE**, rotating it until jointing onto the profile **PF03.01**. Insert the gasket **G** into the space between the glass and glass stop.
- B** Position the spacers **D** (thickness 11mm) on which the glass pane then rests in order to obtain an interpenetration, glass pane/aluminium profile, of 15mm. Use silicone sealant to bond the glass to the aluminium profile. Mount the glass stop profile **FE**, rotating it until jointing onto the profile **PF03.01**. Insert the gasket **G** into the space between the glass and glass stop.

For the choice of **G** and **D**, refer to the LABPROFILES calculation program or the following tables:

<b>G</b>	<b>FE</b>	<b>G</b>	<b>FE</b>
PF03.34	PF03.16	PFS802.001	PF03.16
PFS802.06	PF03.16	PFS802.008	PF03.16
PF03.29	PF03.16	PF03.29	PF03.16
PF03.34	PF03.15	PF03.37	PF03.15
PF03.29	PF03.15	PFS802.00	PF03.15
PFS802.06	PF03.14	PFS802.001	PF03.14
		PFS802.008	PF03.14
		PF03.29	PF03.14

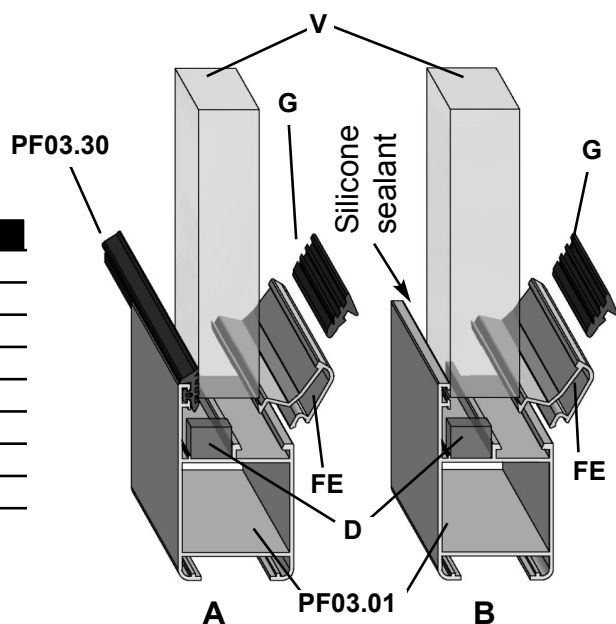

# **MAGNUM**

Aluminium profiles for doors and windows



**SESAMO srl**

Str. Gabannone, 8/10 • 15030 Terruggia (AL) • Italy

Tel: +39 0142 403223 • Fax: +39 0142 403256

[www.sesamo.eu](http://www.sesamo.eu) • E-mail: [info@sesamo.eu](mailto:info@sesamo.eu)