



PL55

**Original
instructions**



Management
System
ISO 9001:2015

www.tuv.com
ID 9105038848



Declaration of Compliance

Rif. DC	TUV IT 26 MAC 516	
Fabbricante	Sesamo s.r.l.	
Oggetto	Porta pedonale motorizzata mod. Powercore PL55, PW100, PW140, PW250, PWT80	
Rif. Doc.	Direttiva 2006/42/CE	

Gruppo di esemplari

I modelli che fanno parte della famiglia POWERCORE, oggetto della presente certificazione, sono i seguenti: PL55, PW100, PW140, PW250, PWT80.

Principali dati tecnici

//

Dati di affidabilità

I circuiti di comando con funzione di sicurezza per i modelli referenziati, raggiungono il PL c, secondo EN ISO 13849-1:2023.

Condizioni di validità

	<p>Il presente documento tecnico è valido solo per l'azienda riportata sullo stesso e per le sue dipendenze.</p> <p>Il diritto di utilizzo del marchio illustrato sul documento copre esclusivamente i prodotti citati nel presente documento.</p> <p>Ciascun prodotto deve essere corredato dalle necessarie istruzioni operative e di assemblaggio. Tutti i prodotti devono chiaramente riportare il nome del fabbricante.</p> <p>Oltre alle condizioni sopra descritte, al presente documento di TÜV Italia si applicano le condizioni effettive del contratto generale.</p> <p>Il documento vale per tutto il tempo in cui si possono ritenere validi i requisiti dello stato d'arte in base al quale è stata eseguita la verifica.</p> <p>Il prodotto preso in esame all'interno del presente documento tecnico non è contemplato dall'Allegato IV della Direttiva 2006/42/CE.</p>
---	---

TABLE OF CONTENTS

0. DECLARATIONS OF INCORPORATION	5
1. INTRODUCTION	6
1.1. INSTRUCTIONS FOR THE INSTALLER (SAFETY OBLIGATIONS) AND RESIDUAL RISKS	6
1.2. WARNINGS FOR THE USER.....	7
1.3. DISASSEMBLY, RECYCLING AND DISPOSAL	8
1.4. SYMBOLS MEANING.....	9
2. PL55 – INTENDED USE / INSTALLATION CONFIGURATION.....	10
2.1. LIMITS OF USE.....	10
2.2. PROHIBITED USE	10
2.3. INSTALLATION CONFIGURATION	11
3. IDENTIFICATION PLATE.....	12
4. TECHNICAL CHARACTERISTICS.....	13
5. OPERATOR COMPOSITION AND INPUT CONFIGURATION	14
6. AUTOMATION INSTALLATION	16
6.1. AUTOMATION TRACK	16
6.2. AUTOMATION FASTENING	17
6.2.1. GETTING STARTED.....	17
6.2.2. TYPES OF SUPPORTS AND FIXINGS	18
6.2.3. OPERATOR FIXING DIMENSIONS.....	18
6.2.4. TRACK FIXING STEPS	27
6.2.5. TROLLEY INSTALLATION.....	32
6.2.6. FINAL ASSEMBLY	38
7. FINAL CHECKS MECHANICAL ASSEMBLY	40
7.1 CONNECTIONS AND COMMISSIONING	40
8. USER MANUAL	41
9. MAINTENANCE MANUAL	49

0. DECLARATIONS OF INCORPORATION

MACHINERY DIRECTIVE

The installer who drives a door becomes the manufacturer of the automatic door machine in accordance with Directive 2006/42/EC and must:

- Prepare the Technical File with the documents indicated in Annex VII of the Machinery Directive and keep it for at least 10 years.
- Draw up the EC declaration of conformity in accordance with Annex II-A of the Machinery Directive and provide a copy to the user.
- Affix the CE marking to the motorised door in accordance with section 1.7.3 of Annex I of the Machinery Directive.

Declaration of Incorporation of partly completed machinery

Machinery Directive 2006/42/EC, Annex II, Part B

Manufacturer: SESAMO S.R.L.

Address: Str. Gabannone 8/10 - 15030 Terruggia – AL – ITALY

Declares that:

The product: Redundant drive for pedestrian sliding doors model **POWERCORE** type **PL55** supplied with serial number XXXX¹

- complies with the essential safety requirements set out in Annex I of the Machinery Directive 2006/42/EC with the exception of the following points: 1.2.4.3, 1.3.4, 1.3.7, 1.3.8.2, 1.5.14, 1.5.15, 1.6.3
- complies with the requirements of the following other European Directives: 2014/30/EU Electromagnetic Compatibility

and that

- the following (parts/clauses of) harmonized standards have been applied:
EN 60335-1, EN 60335-2-103, EN 61000-6-2, EN 61000 -6-3, EN 12100, EN 16005, EN 13849-1, EN 13849-2
and further declares that:

- the relevant technical documentation has been compiled in accordance with Part B of Annex VII; Such documentation, or parts thereof, will be transmitted by post or by electronic means, in response to a reasoned request from the competent national authorities
- the person in charge of preparing the relevant technical documentation is: SESAMO SRL, Strada Gabannone, 8/10 - 15030 Terruggia (AL) - Italy
- it is not permitted to put the product into service until the machinery in which it will be incorporated or of which it will become a component has been identified and its conformity with the conditions of Directive 2006/42/EC and the national legislation transposing it, i.e. until the machinery referred to in this declaration forms a single unit with the machinery.

SESAMO S.R.L.
July 2025



Daniele Amerio
(Administrator)

¹ Refer to the serial number found on the nameplate of the pre assembled operator

1. INTRODUCTION

Thank you for your preference for this product. In order to obtain the best performance from the automation, Sesamo recommends that you carefully read and follow the installation and use instructions in this manual. The installation of this operator must be carried out only by professionally competent persons to whom this manual is addressed. Packaging materials (wood, plastic, cardboard, etc.) must not be dispersed in the environment or left within the reach of children as a potential source of danger. Before starting the installation, make sure that the product is intact and has not suffered damage resulting from transport or poor storage.

Before carrying out any operation, it is necessary to read this manual carefully and follow all its instructions, with particular attention to those marked by the following references:

	DANGER	Indications that, if not scrupulously followed, could generate sources of danger or death
	CAUTION	indications that, if not followed scrupulously, could generate malfunctions

1.1. INSTRUCTIONS FOR THE INSTALLER (SAFETY OBLIGATIONS) AND RESIDUAL RISKS



1A) The operator is supplied with a single package, which can be handled by hand. For handling, refer to the weight indicated on the packaging, considering that for each person the maximum weight that can be handled must not exceed 20 kg.

1B) The doors are supplied packaged on pallets whose weight is indicated on the packaging. The handling of the entire pallet must be carried out with a pallet truck, or by opening the packaging and carrying out the manual handling of the individual pieces as described in point 1 above. In this operation, the use of suitable personal protective equipment is required, at least safety shoes and gloves.

1) It is important for the safety of persons to install the operator in accordance with the instructions. Incorrect installation or incorrect use of the product can cause serious injury to persons. Installation must be done only by qualified and experienced personnel and in full compliance with current regulations.

2) Read the instructions carefully before starting the installation of the product.

3) Keep the instructions for future reference.

4) This product has been designed and constructed solely for the use indicated in this documentation. Any other use not expressly indicated could compromise the integrity of the product and/or represent a source of danger. Every single phase of the installation must be carried out in accordance with the regulations in force and in any TRACK according to the dictates of Good Technique.

5) SESAMO declines any responsibility derived from improper use or use other than that for which the operator is intended and indicated in this documentation.

6) Do not install the appliance in an explosive atmosphere: the presence of flammable gases or fumes constitutes a serious safety hazard.

7) SESAMO is not responsible for non-compliance with Good Technique in the construction of the closures to be motorized, as well as for deformations that may occur during use.

8) Before installing the product, make sure that each architectural and structural element of the entrance (automatic fixing surface, fixtures, etc.) is suitable and robust enough to be automated.

9) Before carrying out any work on the system, disconnect the power supply. Check that there is a residual current circuit breaker with a threshold not exceeding 0.03 A and adequate overcurrent protection upstream of the system. Check that the earthing system is made in a workmanlike manner. Also ensure that it is not possible to restore the electrical supply inadvertently or unintentionally (e.g. padlock switch or plug/socket combination in sight of the technician who is operating the machine).

10) Also disconnect any backup batteries if present.

11) Before connecting the power supply, make sure that the data on the rating plate corresponds to those of the electrical distribution network.

12) Before installing the product, carry out a careful risk analysis and make all structural changes relating to the construction of safety clearances and the protection or segregation of all crushing, shearing, conveying and danger areas in general, in accordance with the provisions of the EN 16005 standard or any local installation regulations. Verify that the existing structure has the necessary requirements for strength and stability

- 13) Fit safety devices of the type in accordance with EN 12978 that allow any danger areas to be protected from mechanical risks of movement in relation to the risk analysis carried out, such as crushing, conveying, shearing. Sesamo declines all responsibility for the safety and proper functioning of the operator if components from other manufacturers are used.
- 14) For maintenance, use only original SESAMO parts. Ask SESAMO for spare parts by indicating the serial number shown on the identification plate.
- 15) Do not make any changes to the components that are part of the automation system.
- 16) The installer must provide all information regarding the manual operation of the system in the event of an emergency.
- 17) The doors to be automated must have a uniform and friction-free opening and closing movement
- 18) Anything not expressly provided for in these instructions is not permitted.
- 19) This manual is intended for professional installers or competent persons only.
- 20) At the end of the installation, give the user this manual, and in particular the WARNINGS FOR THE USER section and any further information for the correct use of the system.
- 21) Upon completion of the installation, apply a door identification plate
- 22) At the end of the installation, assess the possible presence of hazards whose elimination/mitigation is not possible, for example risk of slipping, tripping, falling due to slippery surfaces due to rain, snow, ice and report their presence to the user as residual risks.

1.2. WARNINGS FOR THE USER

 **WARNING** Read and follow the Warnings and Instructions accompanying the product carefully, as improper use may result in damage to persons, animals or property. Keep the instructions for future reference and pass them on to any successors in the use of the system.

This product is intended only for the use for which it was expressly designed. Any other use is to be considered improper and therefore potentially dangerous. The manufacturer cannot be held responsible for any damage caused by improper, erroneous and unreasonable use.

 **GENERAL SAFETY**

Thank you for your preference for this product. In order to obtain the best performance from the operator, Sesamo recommends that you carefully read and follow the instructions for use in this manual

This product complies with recognized technical standards and safety regulations when correctly installed by qualified and experienced personnel (professional installers).

The operator, if installed and used correctly, meets the safety standards in use. However, it is advisable to observe some rules of conduct to avoid accidental inconveniences:

- Keep children out of the range of the automation, particularly during movement.
- Do not allow children to play or stand within range of the automation. Children must not play with the appliance.
- Do not run through the door while the door is closing
- Cleaning and maintenance intended to be carried out by the user must not be carried out by children without supervision.
- Avoid working near hinges or moving mechanical parts.
- Do not oppose the movement of the wing and do not attempt to open the door manually if the actuator has not been unlocked with the appropriate release.
- The breakage or wear of mechanical parts of the door (guided part), such as cables, springs, supports, hinges, guides... could generate dangers. Have the system checked periodically by qualified and experienced personnel (professional installer) as indicated by the installer or door manufacturer.
- Keep the sensor optics clean. Check that objects such as curtains, branches or other objects do not disturb the safety devices.
- Do not use the operator if it needs repair. In the event of a breakdown or malfunction of the automation, disconnect the mains power supply to the automation, refrain from any attempt at repair or direct intervention, and refer only qualified and experienced personnel (professional installers) for the necessary repair or maintenance. To allow exit, turn on the emergency release (if equipped).
- Have the integrity and correct operation of the automation checked by qualified and experienced personnel (professional installers), particularly all safety devices, with the frequency set out in the user manual.
- Installation, maintenance and repair work must be documented, and the relevant documentation must be kept available to the user.
- Failure to comply with the above may create dangerous situations.

1.3. DISASSEMBLY, RECYCLING AND DISPOSAL

WARNING! This product falls within the TRACK of Directive 2012/19/EU concerning the management of waste electrical and electronic equipment (WEEE). The appliance should not be disposed of with household waste as it is made from a variety of materials that can be recycled at the appropriate facilities. Inquire through the municipal authority regarding the location of the ecological platforms suitable for receiving the product for disposal and its subsequent correct recycling. It should also be noted that in the event of the purchase of an equivalent appliance, the distributor is required to collect the product to be disposed of free of charge. The product is not potentially dangerous for human health and the environment, as it does not contain harmful substances as per Directive 2011/65/EU (RoHS), but if abandoned in the environment it has a negative impact on the ecosystem.



Dismantling operations must be managed by qualified and experienced personnel and in full compliance with current regulations. These operations must include:

- Disconnect the mains power supply and batteries if present.
- Disconnect all electrical cables connecting to external devices
- disassembly of sliding and fixed sashes using due care to prevent the fall of the sashes themselves or components such as sliding carriages.
- Dismantling the operator















The symbol of the crossed-out wheeled bin indicates that this product complies with the regulations relating to waste electrical and electronic equipment. Leaving the equipment in the environment or illegally disposing of it is punishable by law.

1.4. SIMBOLI MEANING

	DANGER	Indications that, if not scrupulously followed, could generate sources of danger or death
	CAUTION	indications that, if not followed scrupulously, could generate malfunctions
	WARNING RISK OF ELECTROCUTION	Indicates a risk of electrocution. The operation must be carried out in compliance with safety regulations

	Obligation in TRACK of protection.
	Safety shoes are mandatory.
	Mandatory mask/goggles suitable for eye protection.
	Work gloves are mandatory.
	Ear protections are mandatory.
	Mandatory overalls.

	Hex Wrench + Size		Circular saw
	Allen key + size		Metal drill bit
	Socket wrench		Masonry drill bit
	Flat screwdriver		Thread Tap M...
	Phillips screwdriver		Bubble / Level
	Torque Adjustable Tool  Nm		Wire stripping pliers

2. PL55 – INTENDED USE / INSTALLATION CONFIGURATION

The PW140 operator must only be used for the movement of sliding pedestrian doors.

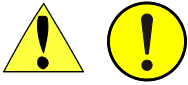

Any other use, other than that stated in the chapter, is NOT PERMITTED by the installer. Sesamo declines any responsibility derived from improper use or use different from that for which the automation is intended.

2.1. LIMITS OF USE

The PL55 operator must not be used under the following conditions:

- Direct exposure to the elements
- Direct exposure to water jets of any size or flow rate
- Outside the prescribed technical limits
- Connections to energy sources other than those prescribed

2.2. PROHIBITED USE

It is forbidden:

- Use automation DIFFERENTLY FROM ITS INTENDED USE.
- Use automation to make entrances for fire and smoke protection.
- Use automation on escape routes unless the window is equipped with a knock-down panic system; conversely, it is necessary to use the automation equipped with a suitable fail safe system in accordance with the product standard
- Use the automation in places where there is a risk of fire/explosion (presence of gases, flammables, etc. the product is not certified with the ATEX directive).
- Integrate unforeseen commercial parts
- Integrate commercial parts for uses not permitted by their respective manufacturers.
- Use commercial devices for use other than as intended by their manufacturers.

2.3. INSTALLATION CONFIGURATION

The operator is designed to work with different configurations of accessories and peripherals. The image shows an example of a complete installation where the possible access points in the track of the operator for the connection of the following peripherals are highlighted.

Fig.1

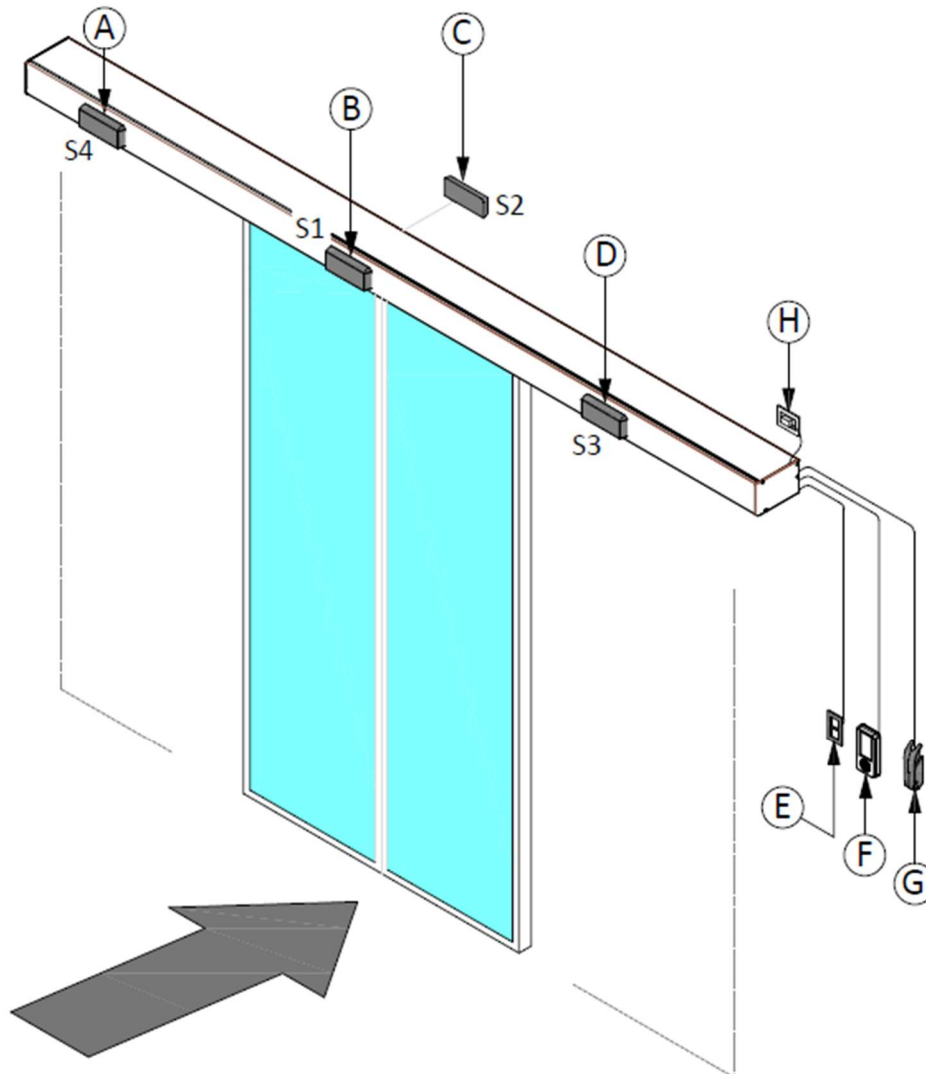

A	Safety sensor on the left side opening.	E	Residual current circuit breaker (230Vac mains power supply). NOT PROVIDED
B	Internal safety sensor when closing and opening control.	F	Icon/Digidor/RotoK3/RotoK5 operating logic selector
C	External safety sensor when closing and opening control.	G	Lever for manual electro-lock release (Optional, with electric lock).
D	Safety sensor on the right side	H	230Vac power supply.

Prepare the access points inside the automation to allow them to be connected with external peripherals. To pass the mains power cable, use the notch provided on the head or make one affixed to the aluminium TRACK profile. Protect the cable with the cable rubber supplied.

WARNING: Do not damage the cable during the fastening tasks described.



3. IDENTIFICATION PLATE

SESAMO s.r.l.
 Strada Gabannone 8/10 15030 TERRUGGIA (ITALY)
 Tel +39 0142 403223 Fax +39 0142 403256
 www.sesamo.eu E-MAIL info@sesamo.eu

PEDESTRIAN SLIDING DRIVE

Series POWERCORE Type PL55

Serial Nr AA1H42-FC40653

Year of manufacturing 2025
 Power supply 230 V ~ 50 / 60 Hz 200 W

AA1H42-FC406530

- Automatism Model (Type): AA = PL55
- No. of doors: 1 = 1 leaf, 2 = 2 doors
- Month of production: A = January, B = February, C = March,
- Year of production: 42 = 2025, 43 = 2026, 44 = 2027,
- Code generated by the system that makes the cross beam UNIQUE.

The label will be applied as shown in the image to the right or left ends depending on the arrangement of the components:

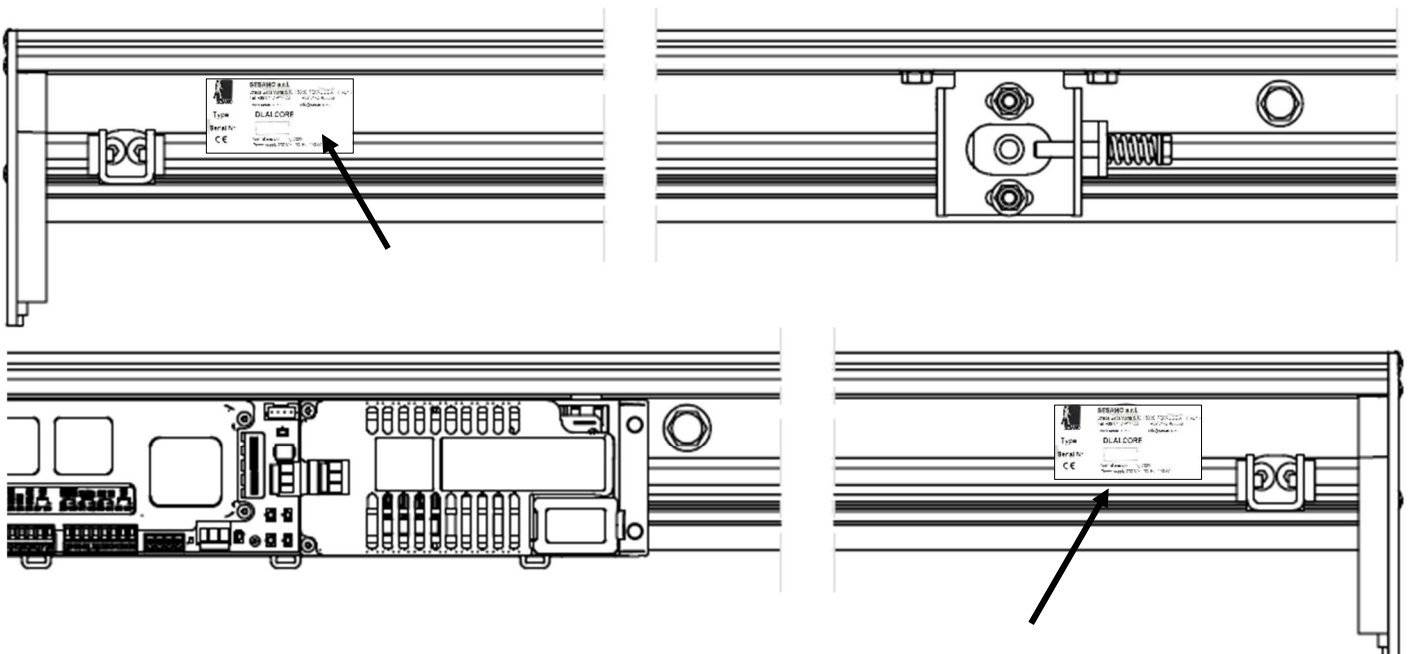

4. TECHNICAL FEATURES

Dimensions	
Allowed dimensions mm	<p>1 Wing PL55 = passage compartment 700 minimum ÷ 3000 maximum – maximum height 3000</p> <p>2 Wings PL55 = passage compartment 900 minimum ÷ 3000 maximum – maximum height 3000</p>
Automation weight	11 kg/m approx.
Flow rate	<p>1 Wing PL55 = 55 kg</p> <p>2 Wings PL55 = 55+55 kg</p>
Power supply	230V ±10% AC 50/60Hz
Rated power	130 W
Service	Intensive
Main engine	Powered by 40Vdc
External devices	Powered 12Vdc - 12W MAX
Auxiliary power system	Battery – 24Vdc
Traction	By drive belt
Opening speed	<p>1 Wing = 70cm/s</p> <p>2 Wings = 140 cm/s</p>
Anti-crush	Automatic force limitation in the presence of obstacles
Operating Temperature	-10°C +55°C
Protection	IP20
Emitted noise	< 70 dB (A)

5. OPERATOR COMPOSITION AND INPUT CONFIGURATION

A	Extruded aluminum track
B	Extruded aluminum scovere rail
C	Anti-vibration rubber for scovere rail
D	Extruded aluminum cover
E	Gasket for extruded cover
F	Brush (Optional, available in 3 sizes)
G	Extruded aluminium gap closer profile (Optional)
H	POWERCORE Control Module
I	Gear motor with encoder - type 63x55 SG80 gearbox
L	Belt support and tensioning screw
M	Range of electric locks (Optional)
N	Door limit switch
O	Adjustable carriages complete with wheel and anti-derailment wheel
P	Belt clamp with toothed drive belt
Q	Electric lock Striker (Optional)
R	Drive belt
S	Battery module – auxiliary back up power (Optional)
T	Digidor, Icon and key switch logic selectors

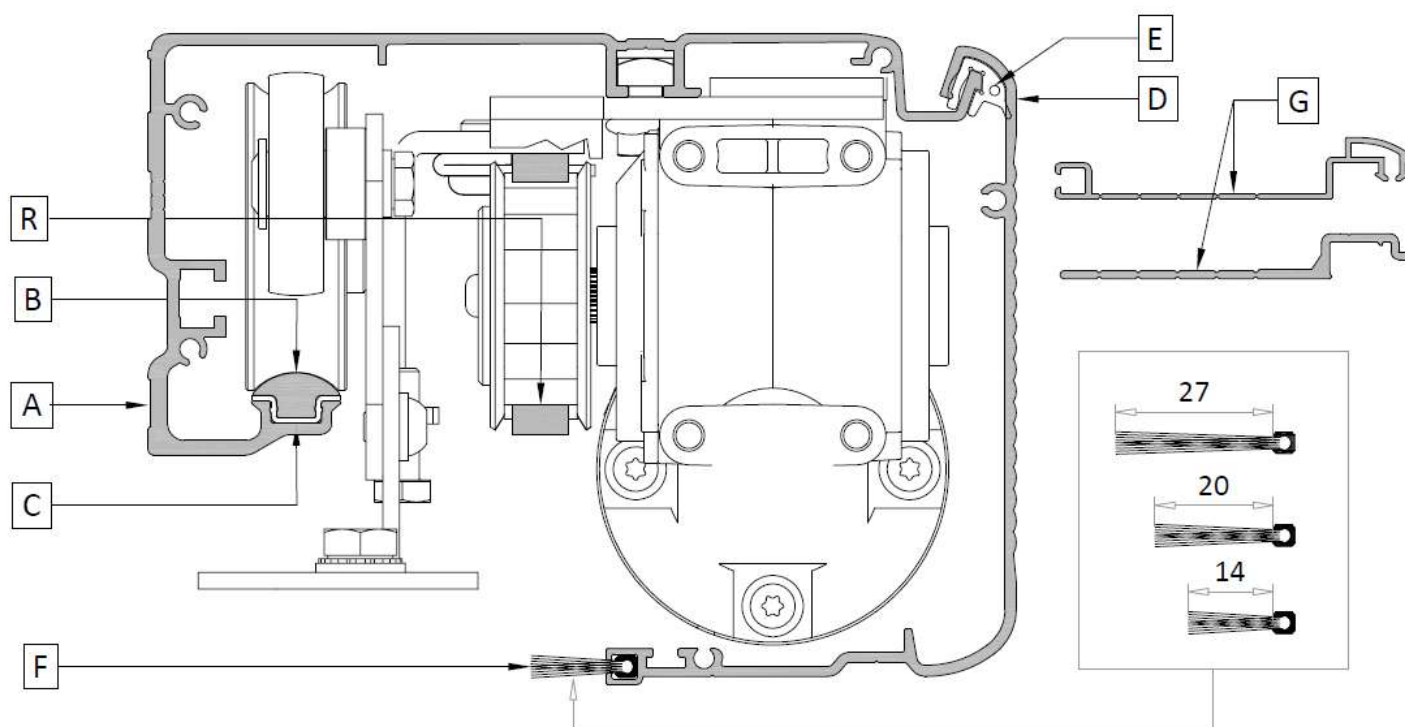

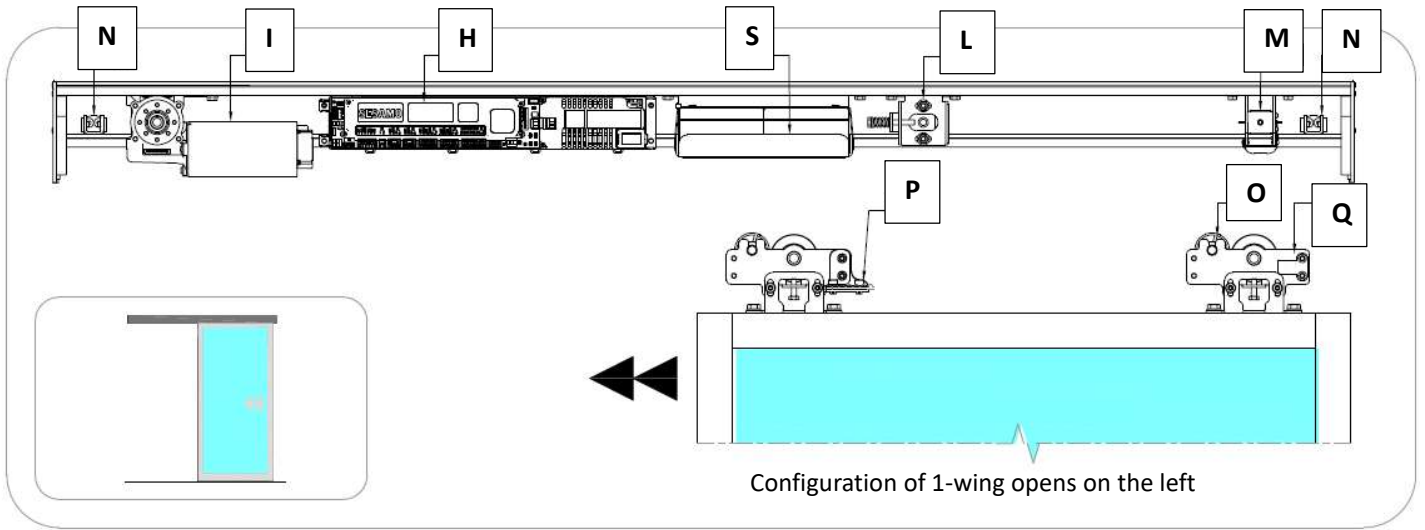

Configuration of 1-wing opens on the left

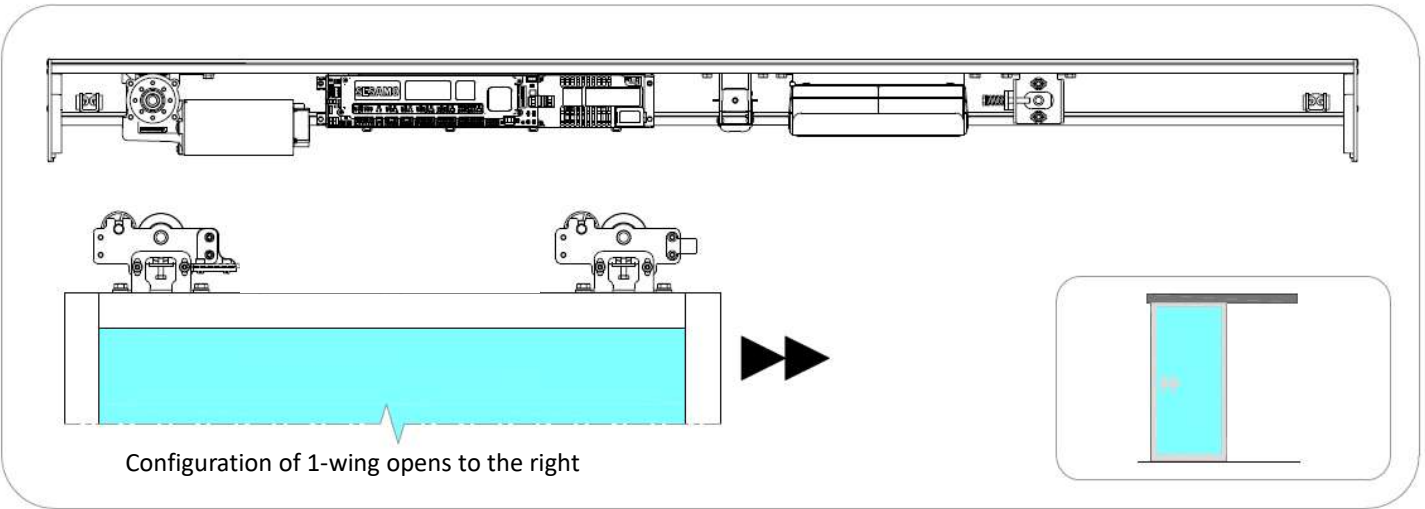

Configuration of 1-wing opens to the right

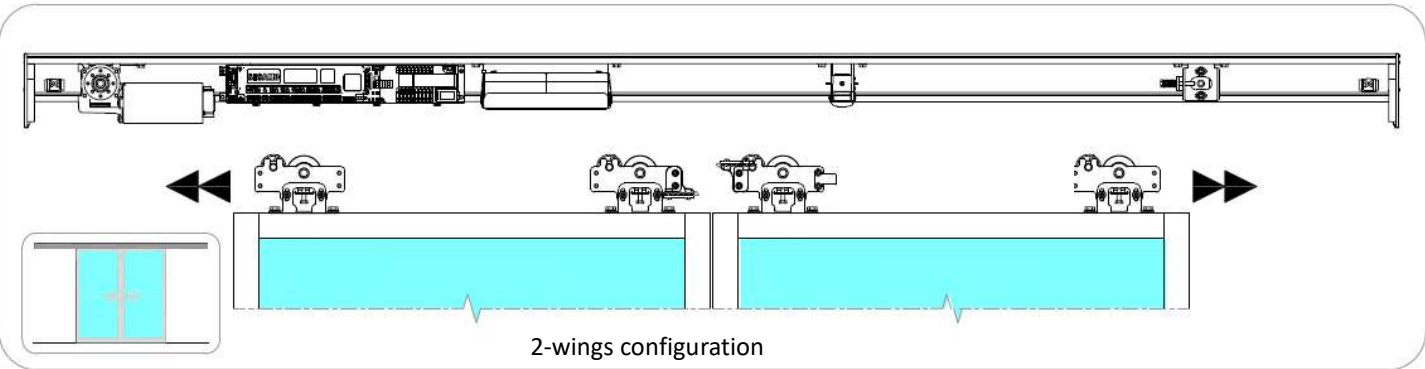

2-wings configuration

T







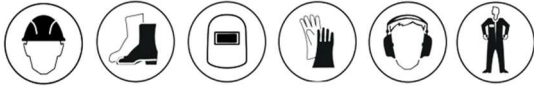



6. INSTALLATION OF OPERATOR

Individual devices for all operating phases:



List of equipment needed:

	Measurements: 8-10-13
	Measurements: 8-10-13
	Size: 0.8
	Type: Ph n.2

	Sizes: 3-5
	Measurements: $\varnothing 6$
	Sizes: $\varnothing 6.5 - \varnothing 10$
	-

6.1. OPERATOR'S TRACK

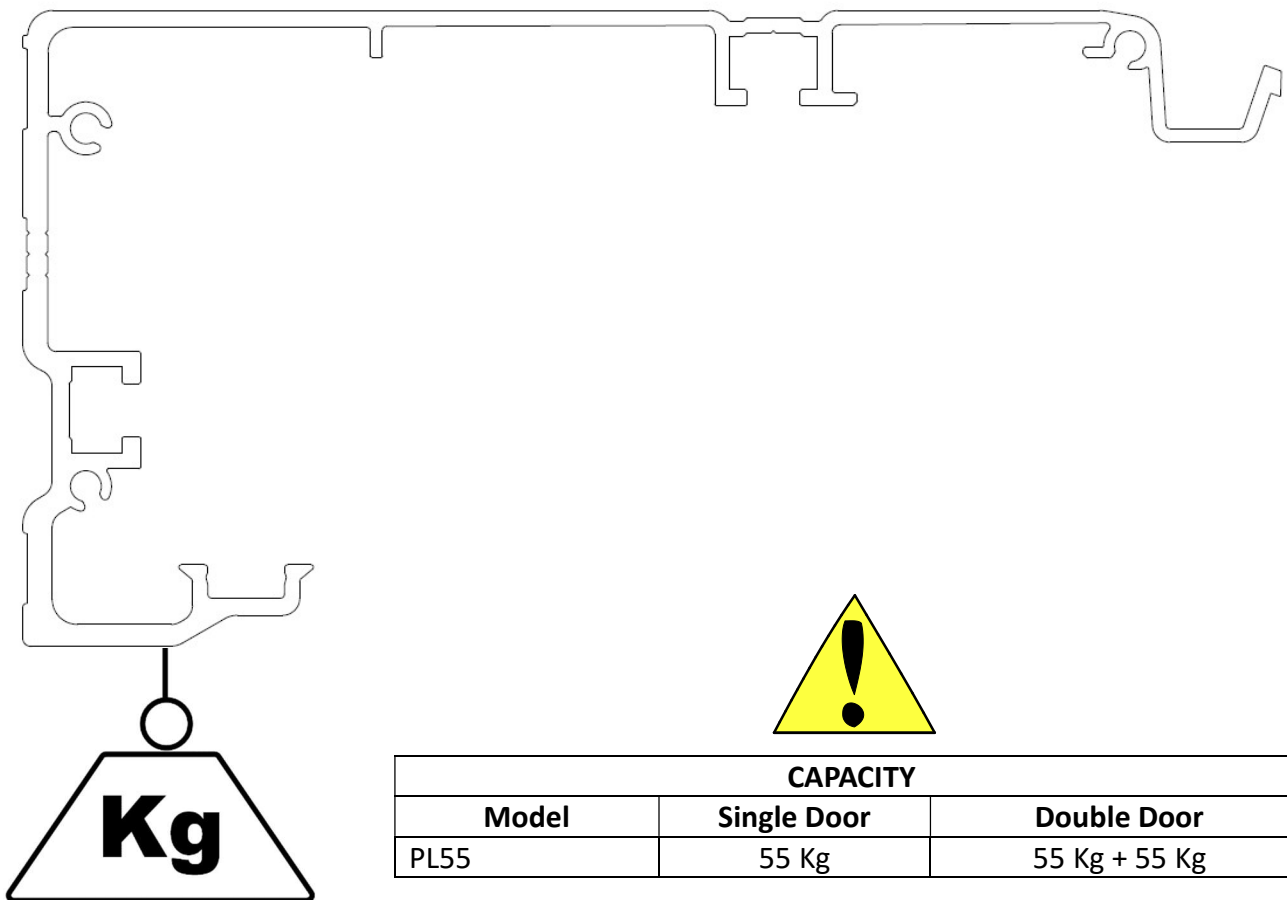

CAPACITY		
Model	Single Door	Double Door
PL55	55 Kg	55 Kg + 55 Kg

6.2. OPERATOR'S FASTENING

6.2.1. GETTING STARTED



The installation and fixing phases of the operator require the handling of heavy parts and tools at a height of more than 2 or 3 meters. Accidental falling of heavy parts and tools is a serious source of risk to people or property in the vicinity. To reduce this risk, before any installation or maintenance work, it is necessary to fence off a sufficiently large area around the work area and prevent access to all persons not involved in the work, as well as remove any objects that could be damaged. To reduce the risk to workers, it is necessary to wear personal protective equipment and in particular a head helmet, safety shoes and cut-resistant gloves.

Remove the fixing screws and open the cover as shown in the pictures:



Type: Ph n.2 - Half-round head screw with cross notch + 4.2x16 self-tapping

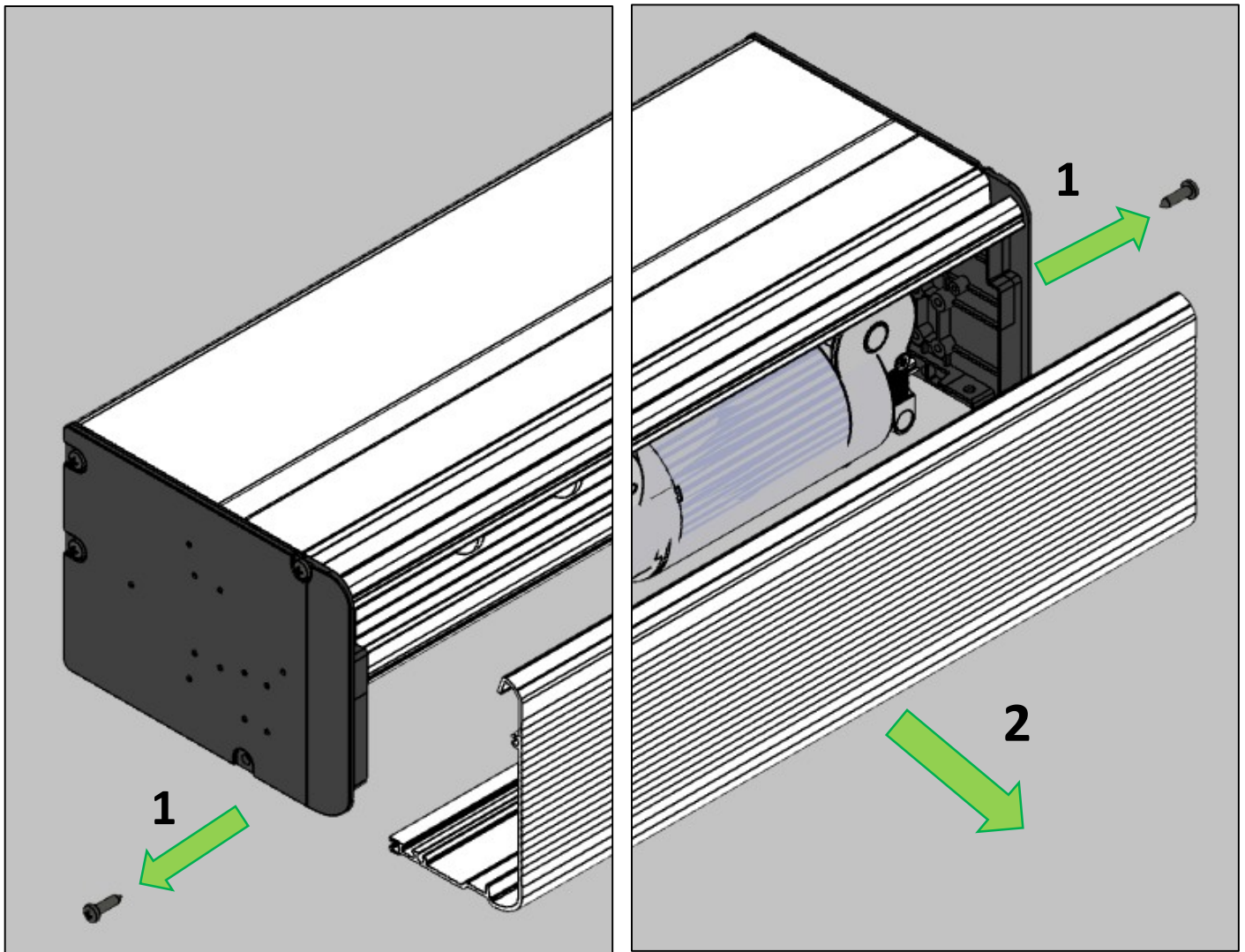

To facilitate the wall fixing of the track, it is possible to move (A) or remove the internal components simply by acting on the screws that fix it (B).

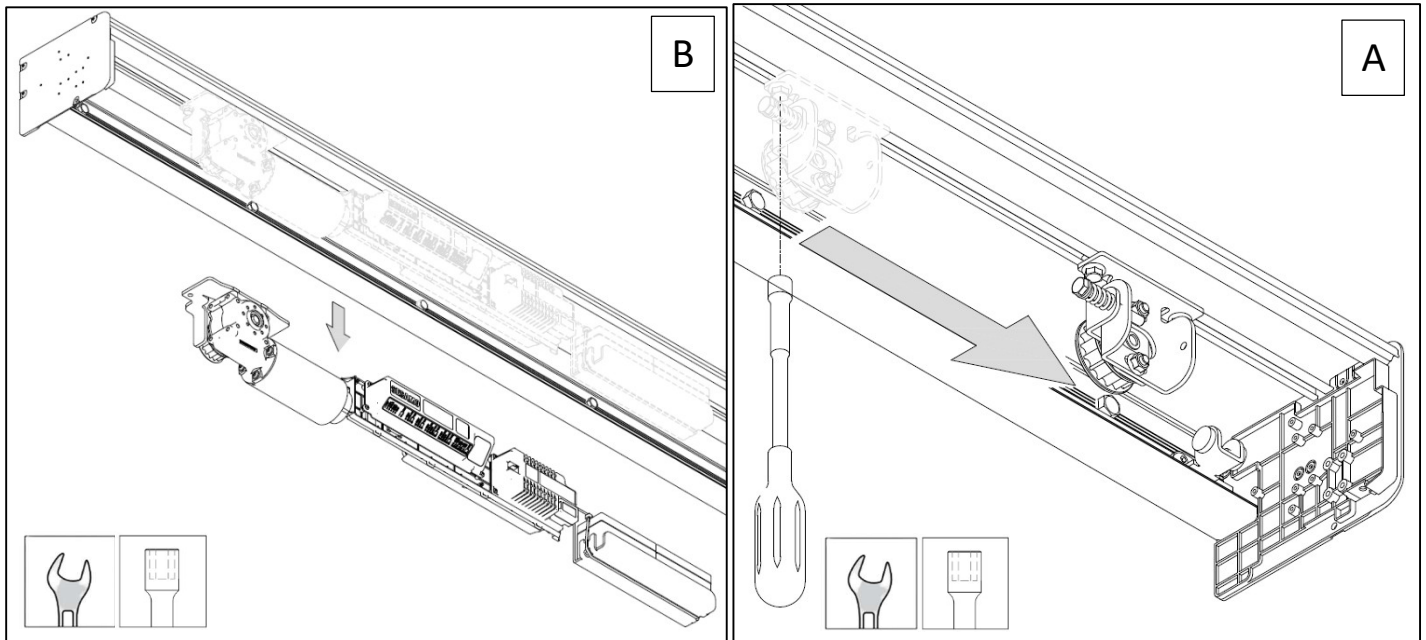

Before moving or removing internal components, take note of their positions or draw reference marks on the track so that they can be correctly positioned.

6.2.2. TYPE OF SUPPORTS AND FIXINGS

Wall mounting support:

Inspect the plane on which the operator will be fixed. If the surface is not smooth enough, level it by interposing shims. If the operator is fixed on a plane that is too uneven, it can be deformed. Make sure that the masonry to which the track and subsequently the sliding doors will be fixed is sufficiently strong and is anchored to the building in an adequate way.

Support for fixing to aluminium structures:

It is possible to use one of the fixing structures made with Sesamo Twenty, S30 or Magnum series profiles with the indications given in the appropriate manual. Do not use any other type of fastener.

Type of fixings:

Fix the track using all the slots and holes made on the casing profile with screws of the following type. If there are no holes or slots on the profile, drill every 300mm.

Fixing on aluminium self-tapping screw Hexagonal head with flange C15 DIN 6928 UNI 6950 measures 6.3 x 22. Wall fixing: M8 dowels of suitable type in relation to the masonry.

6.2.3. OPERATOR FIXING DIMENSIONS

6.2.3.1 DOOR FIXING



Carefully check the weight of the wings so that they fall within the maximum capacities allowed by the automatism; in TRACK of doubt, do not proceed further in the installation phases; if wings are installed with a weight at the limit of the system's capacity, shorter maintenance intervals and periodic checks must be provided to assess the state of wear and tear of the parts of the system; Always replace parts that show signs of wear, even slight.



Incorrect fastening could affect the correct functioning of the operator and constitute a source of danger.

6.2.3.2 HORIZONTAL POSITION

N.1 door opens on the left

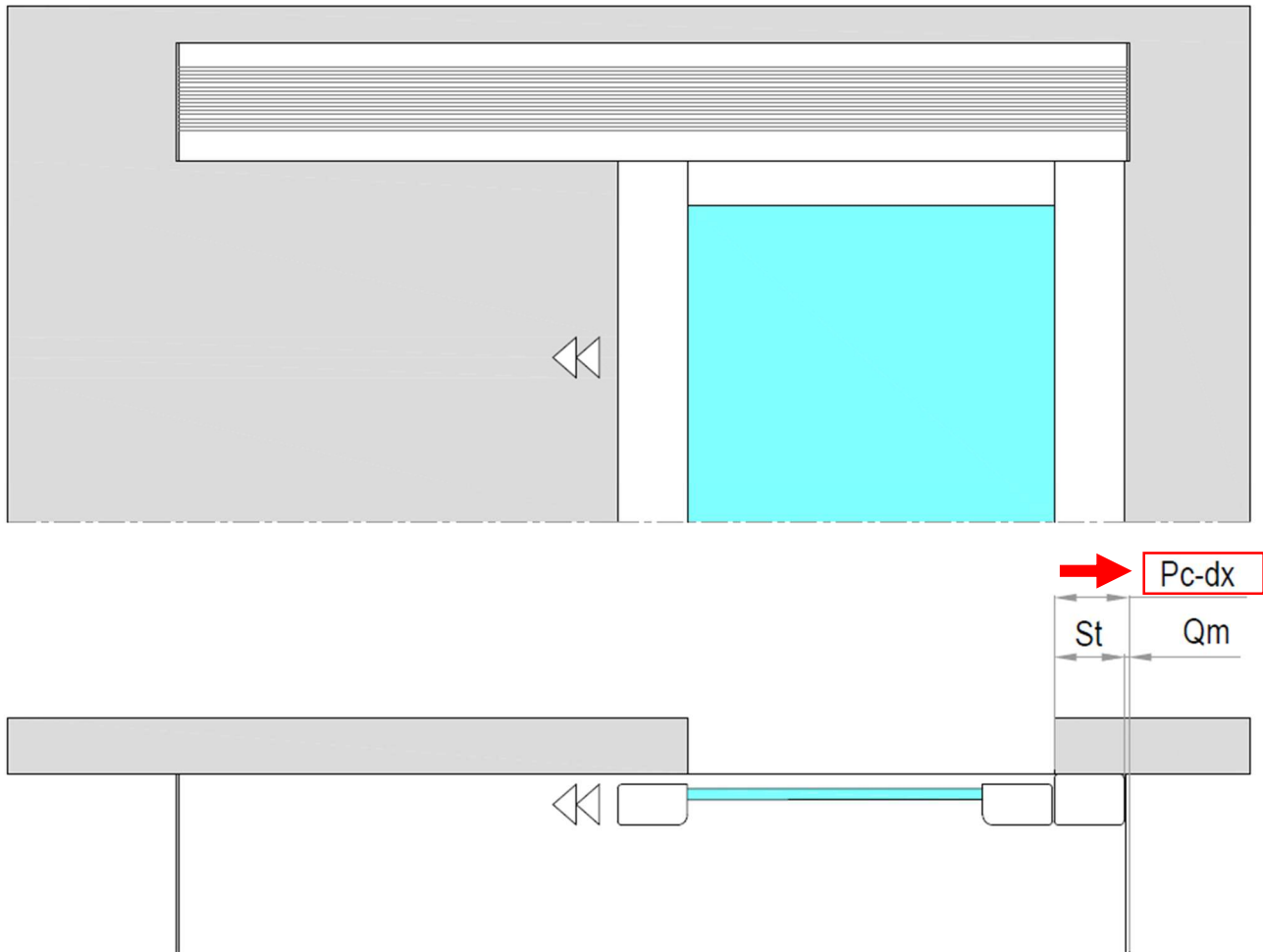

LEGEND	DESCRIPTION	FORMULA
Pc_Dx	Right Cash Position	$St + Qm$
Qm	Machine Quotient	Depending on the selection Min. 5mm
St	Overlapping	Dependent on profiles series

N.1 door opens on the right

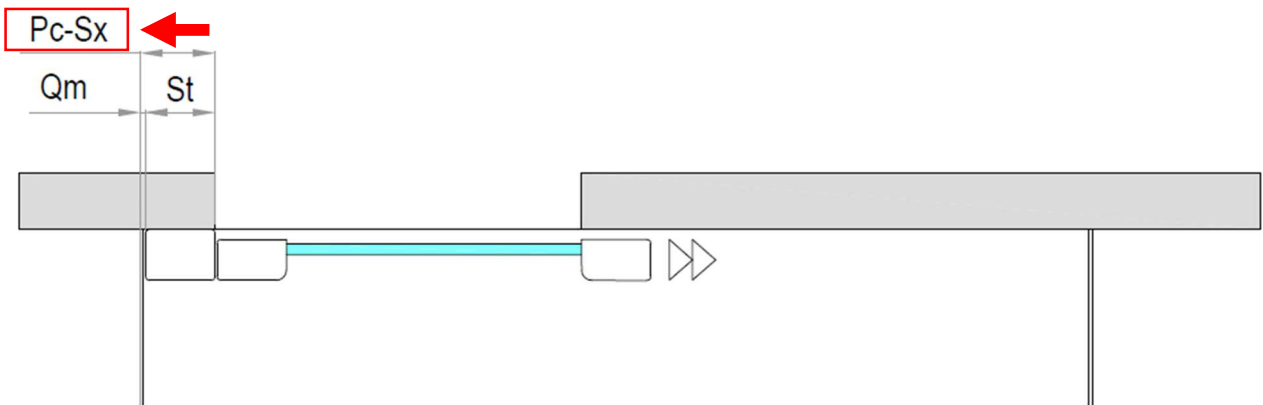

LEGEND	DESCRIPTION	FORMULA
Pc_Sx	Left Cash Position	$St + Qm$
Qm	Machine Quotient	Depending on the selection Min. 5mm
St	Overlapping	Dependent on profiles series

N.2 doors

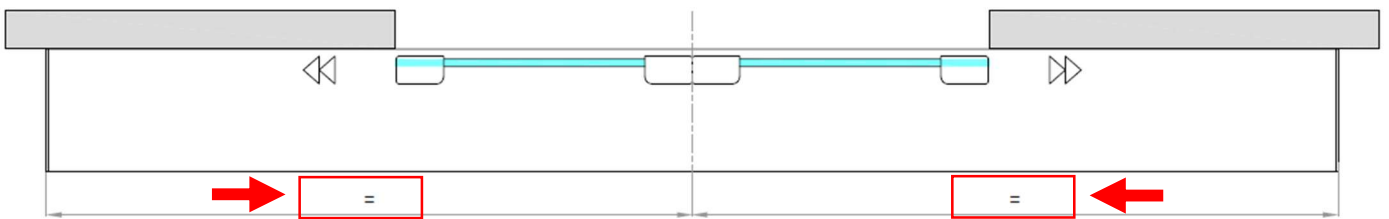
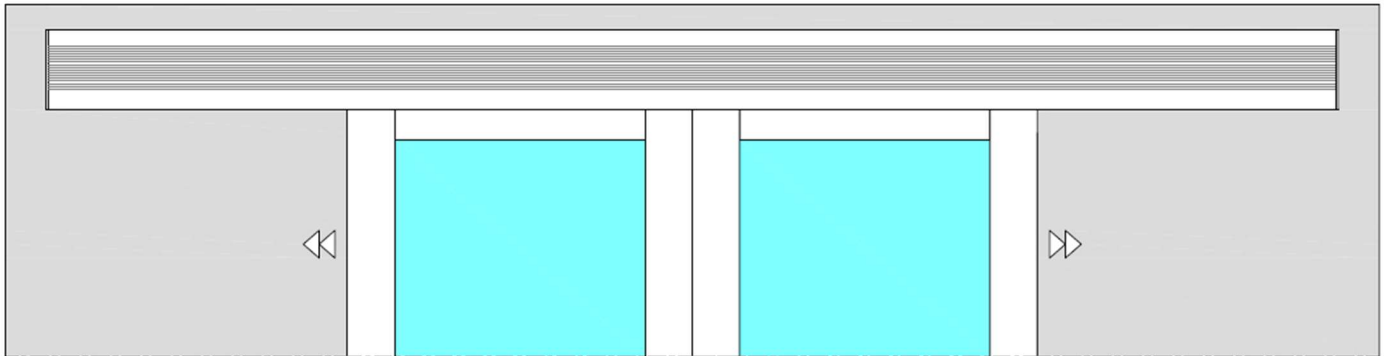

LEGEND	DESCRIPTION	FORMULA
=	Checkout position	Centered in the clear opening
Qm	Machine Quotient	Depending on the selection Min. 5mm

6.2.3.3 VERTICAL POSITION

The vertical position varies from the type of window installed and the type of assembly, below is the table with all the formulas TRACK by TRACK. From the table it will be possible to obtain the height of the sliding door.



In order to remove the cover for inspection, the automation must have a space of at least 10mm from above the casing.

LEGEND	DESCRIPTION
H	Wall opening height
HUP	Useful passage height
HCA	Track height
HF	Track fixing hole height

SAWING	FIG.	H	HUP	HCA	HF
Commercial	1	By relief	H=HUP	HUP+40	HCA+46,5
Twenty on the wall	2	By relief	H=HUP	HUP+46	HCA+46,5
Twenty on the wall with fixed door	3	By relief	H-11	H+35	HCA+46,5
Twenty with band and fixed door	4	By relief	H-125-IH	HUP+40	HCA+46,5
S30 with fixed wing	5	By relief	H-40	H+17	HCA+46,5
S30 sliding only	6	By relief	H=HUP	H+50	HCA+46,5
Magnum sliding only	7	By relief	H-26	HUP+46	HCA+46,5
Magnum with band and fixed door	8	By relief	H-152-IH	HUP+46	HCA+46,5

Fig.1 – Commercial profiles and Sesamo adapter

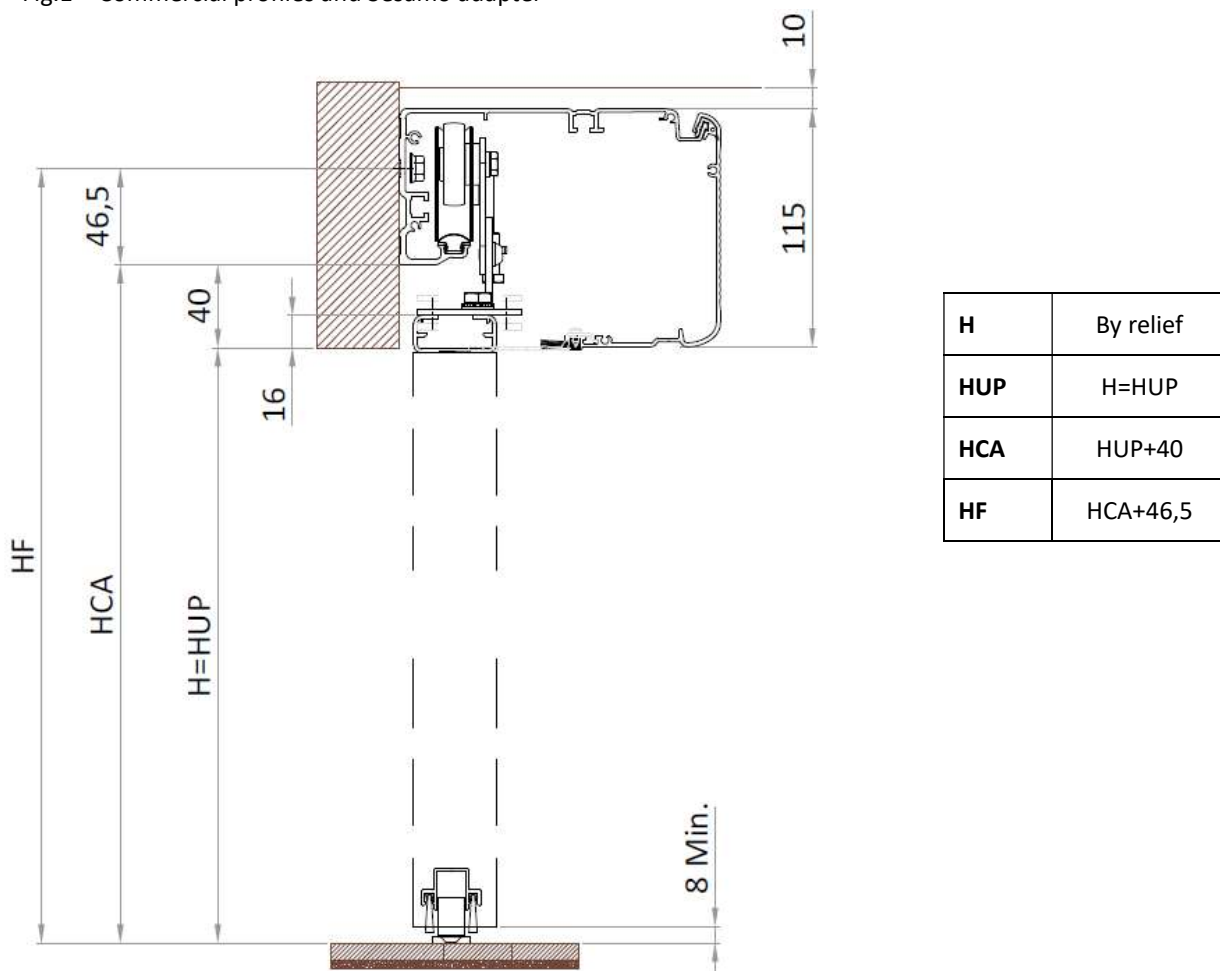
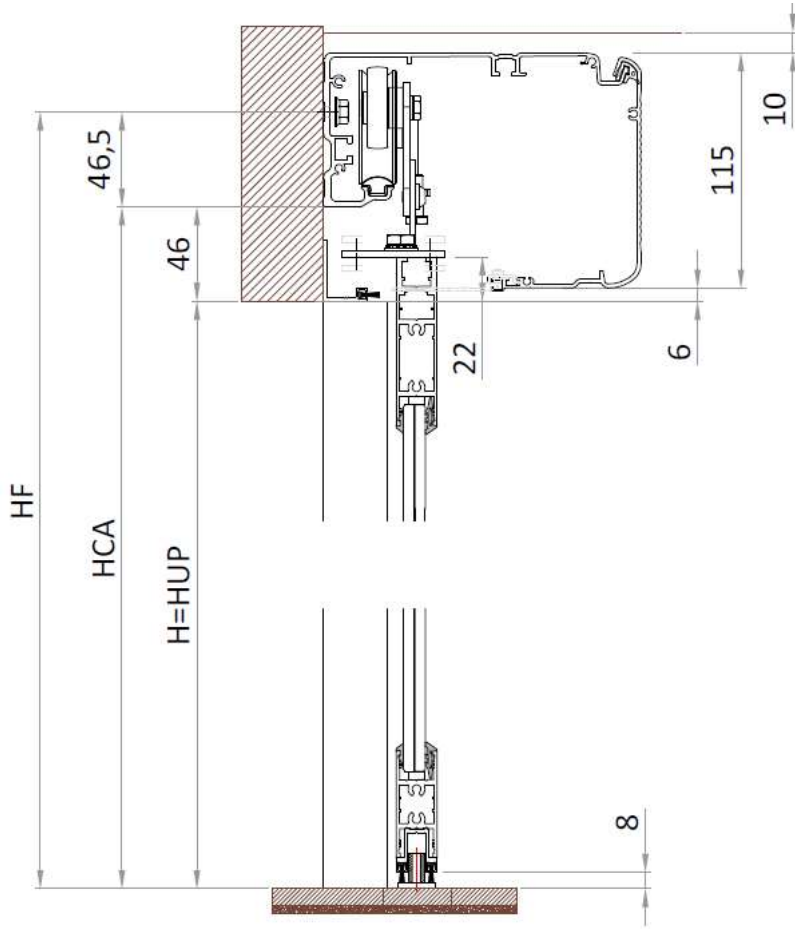
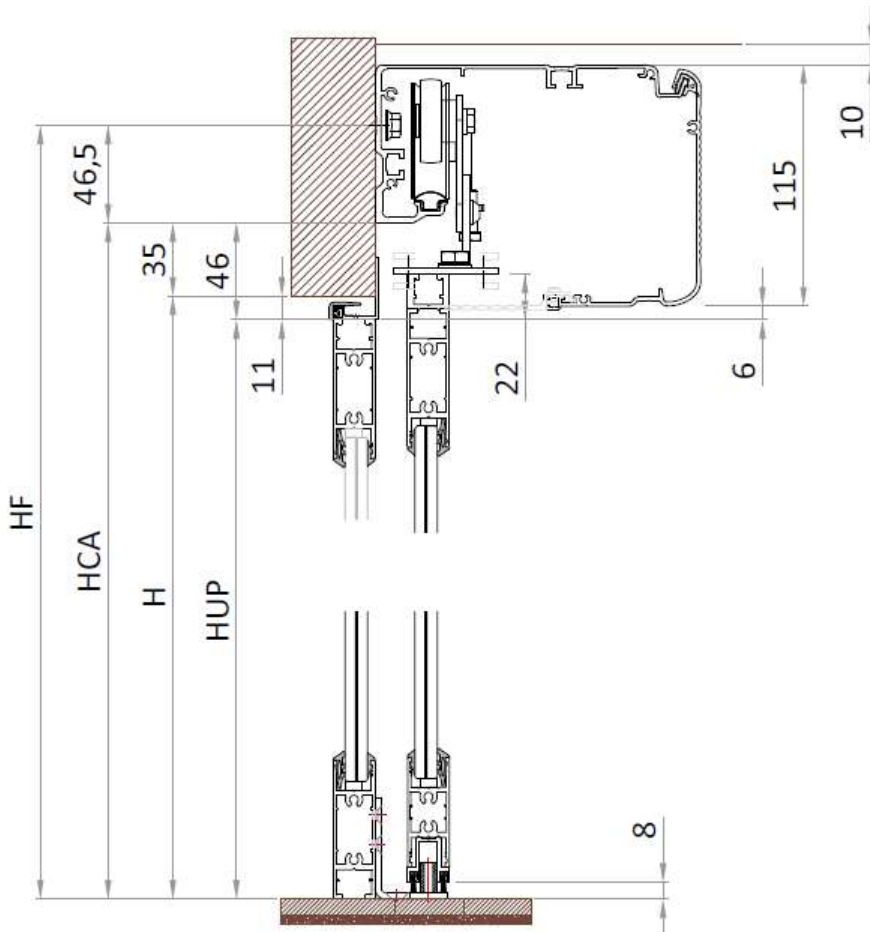

Fig.2 -Twenty on the wall



H	By relief
HUP	H=HUP
HCA	HUP+46
HF	HCA+46,5

Fig.3 – Twenty on the wall with fixed wing



H	By relief
HUP	H-11
HCA	H+35
HF	HCA+46,5

Fig.4 – Twenty with band and fixed wing

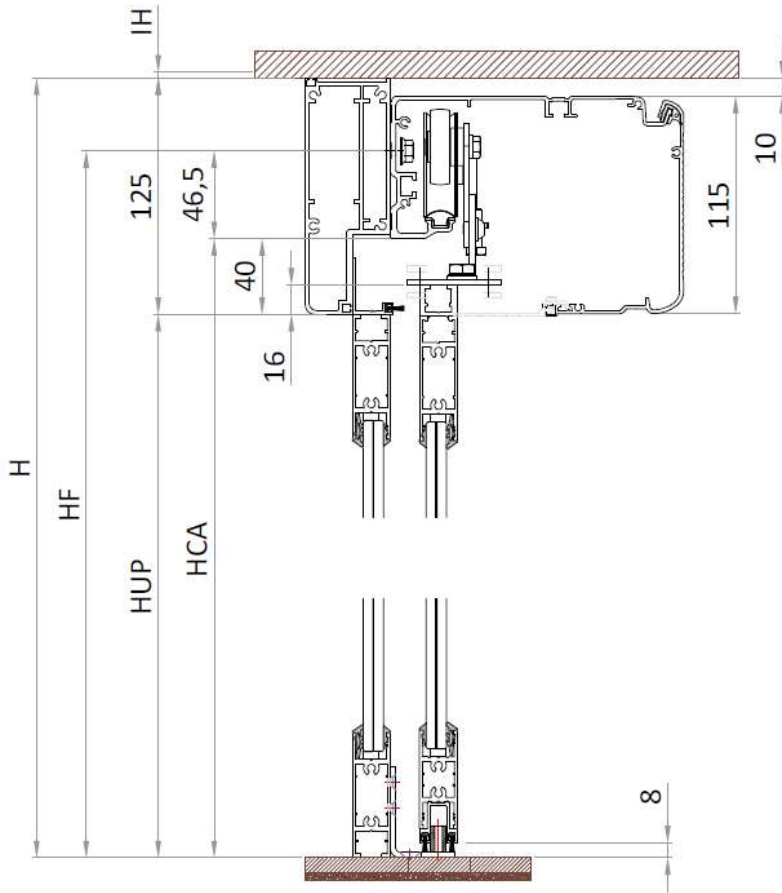

H	By relief
HUP	H-125-IH
HCA	HUP+40
HF	HCA+46,5

Fig.5 – S30 with fixed wing

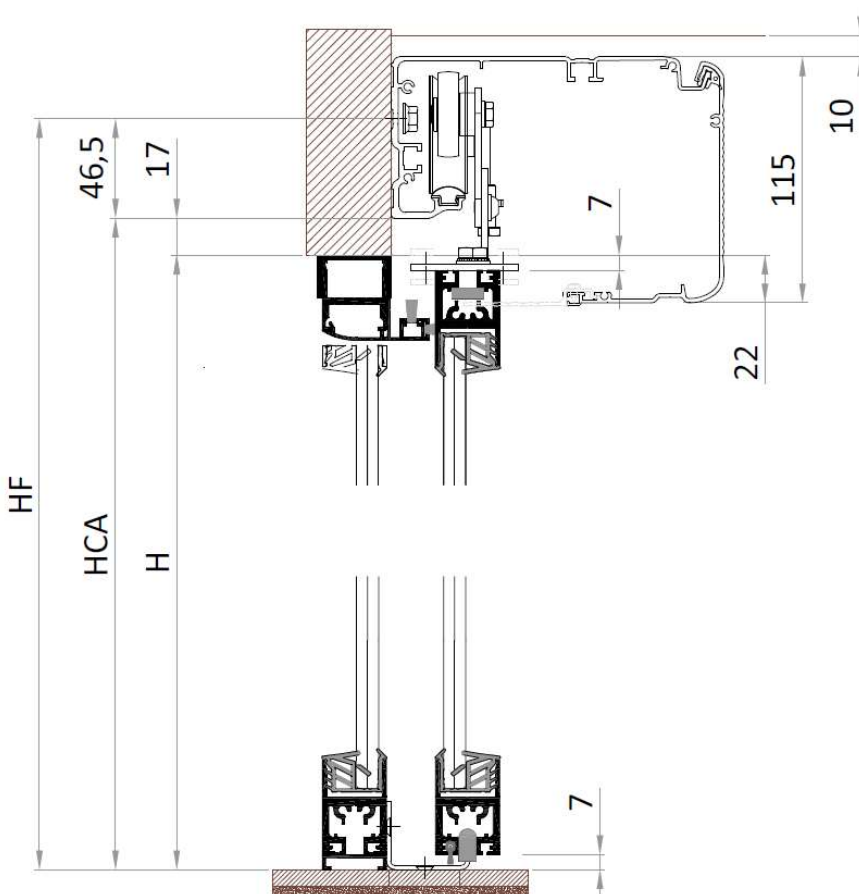

H	By relief
HUP	H-40
HCA	H+17
HF	HCA+46,5

Fig.6 – S30 sliding only

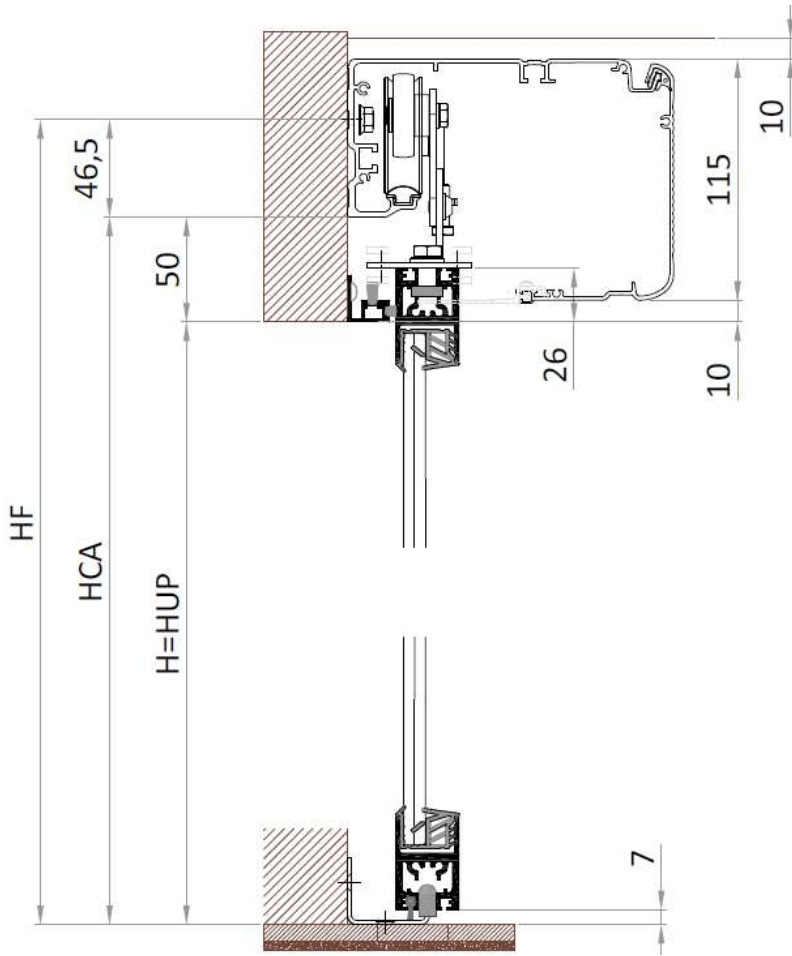

H	By relief
HUP	H=HUP
HCA	H+50
HF	HCA+46.5

Fig.7 – Magnum sliding only

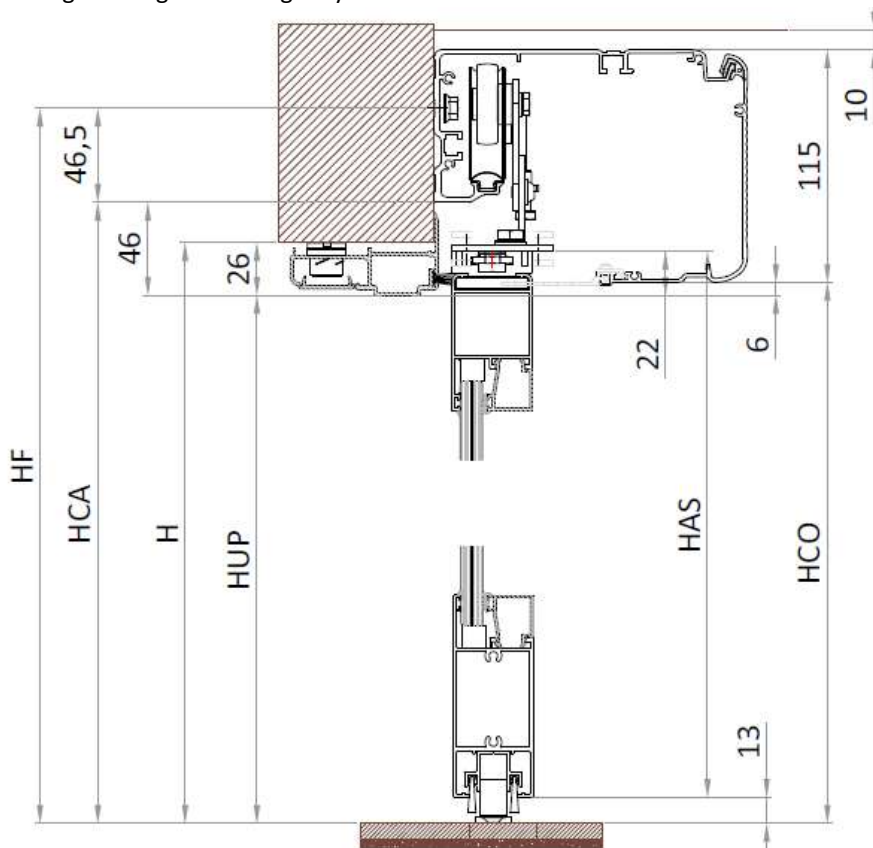

H	By relief
HUP	H-26
HCA	H+46
HF	HCA+46.5

Fig.8 - Magnum with band and fixed wing

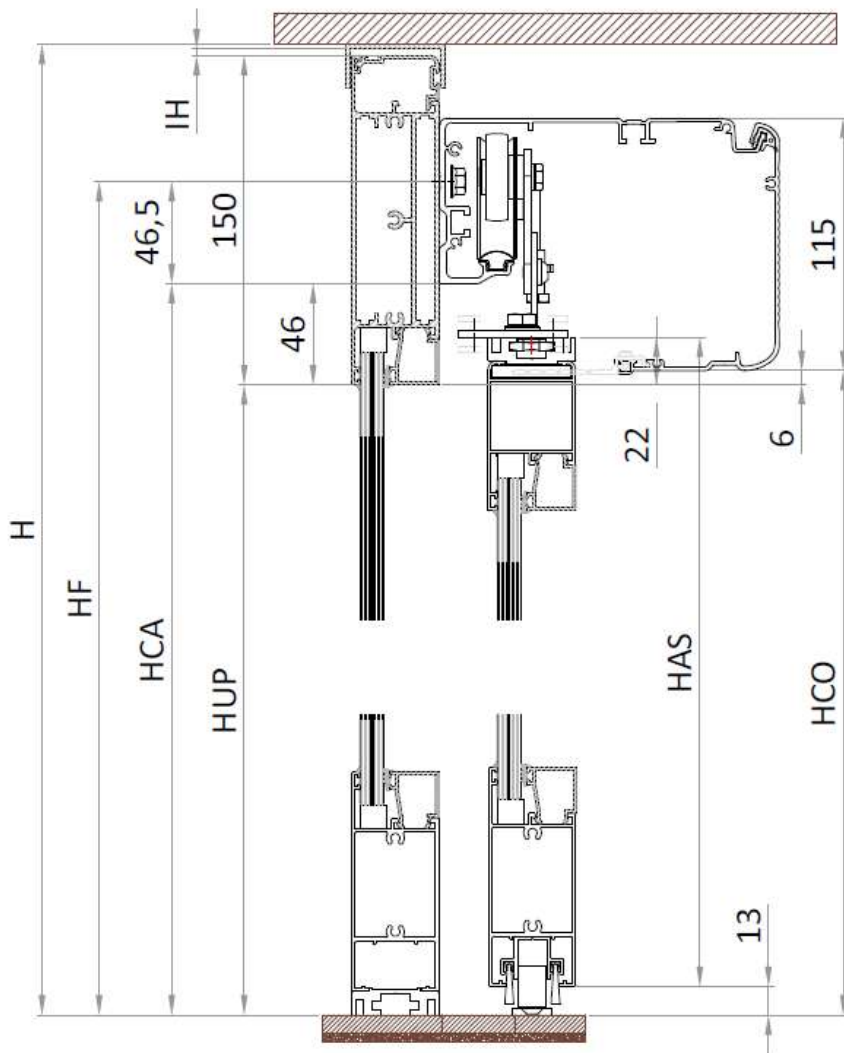

H	By relief
HUP	H-152-IH
HCA	HUP+46
HF	HCA+46.5

6.2.4. TRACK FIXING PHASES



Failure to comply with the instructions relating to the fixing of the track may compromise the stability of the fixing itself with consequent detachment and fall of parts. It is necessary to carefully check the support structure, the tightness of the fixing screws or dowels and in TRACK of doubt, stop the installation and carry out more in-depth investigations.

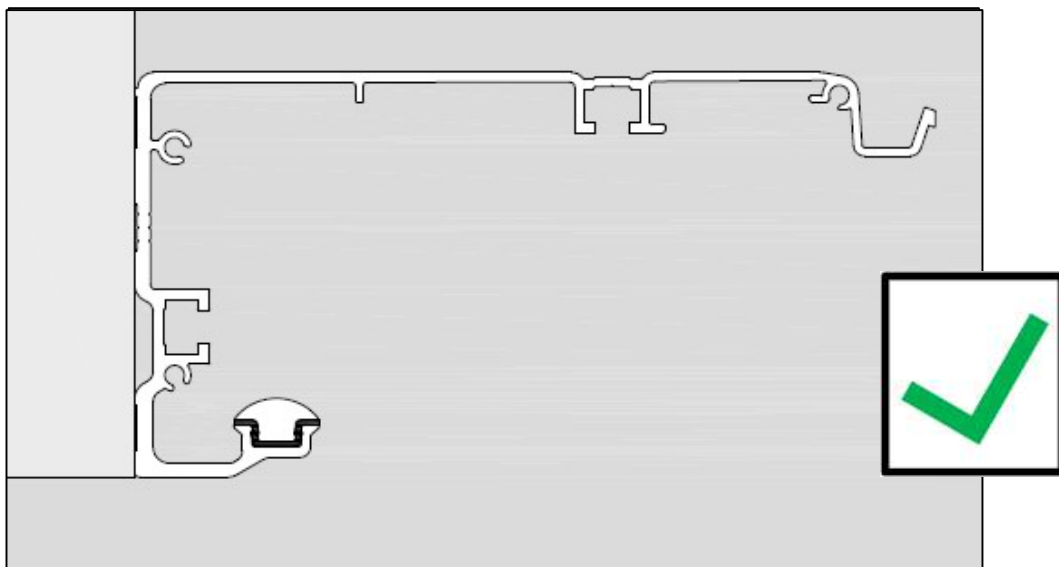
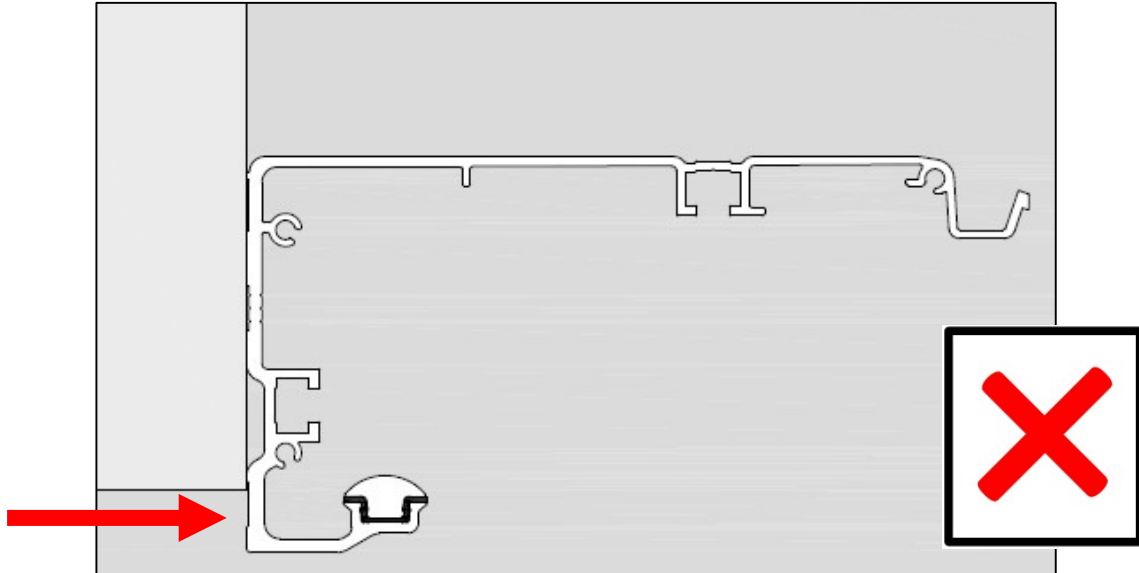

Before tightening the track fixing screws, make sure that the beam is "level" in the direction of length and depth as shown in the figure. Positioning errors could compromise the correct functioning of the operator and constitute a source of danger.

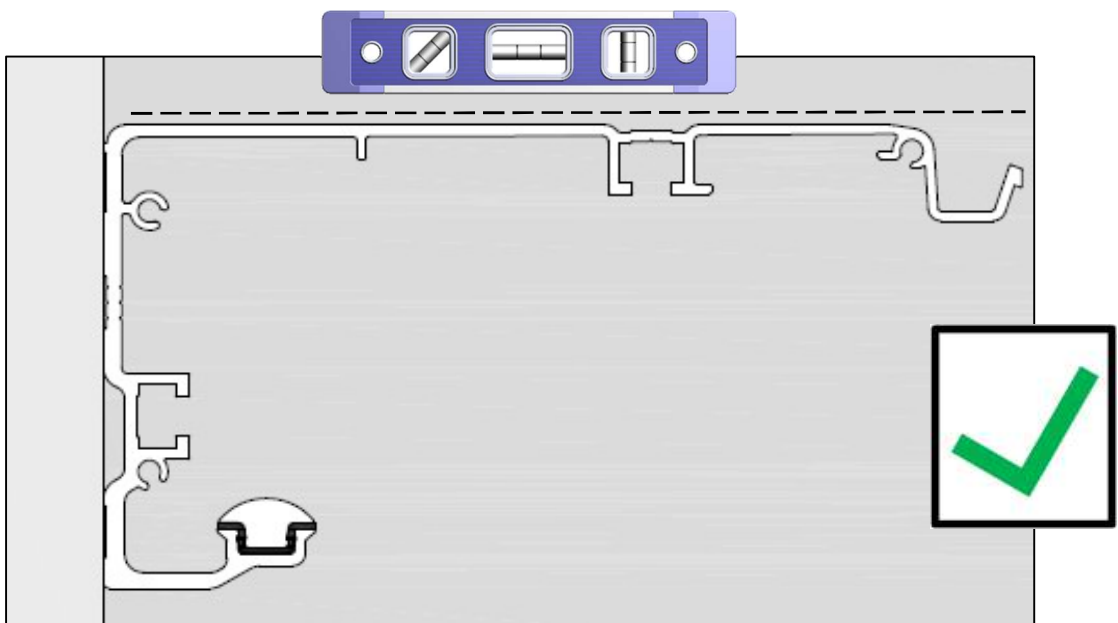
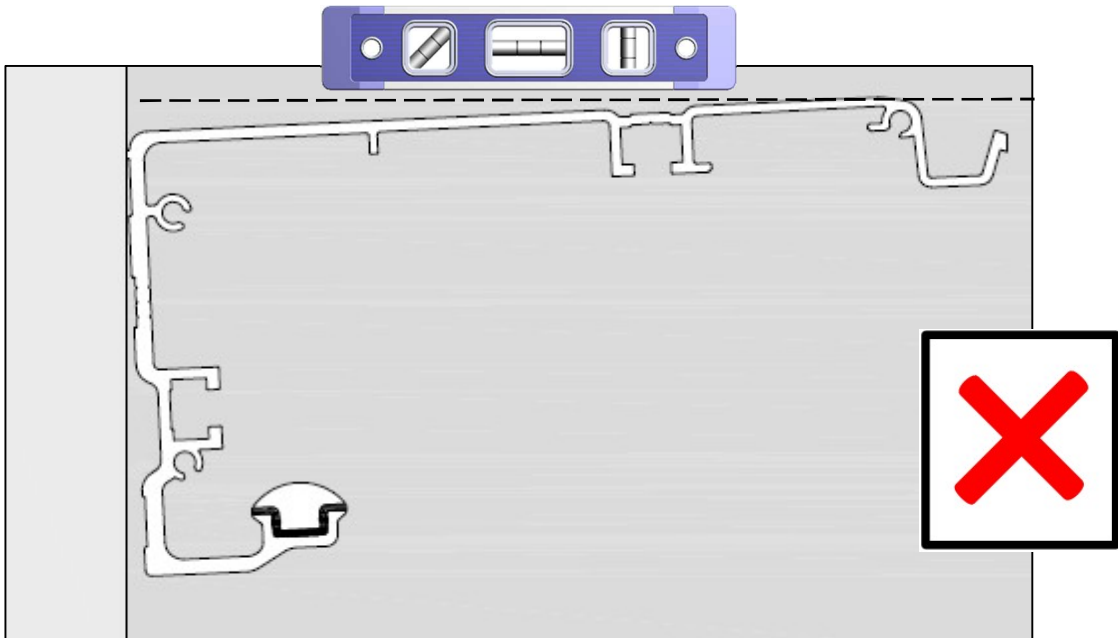
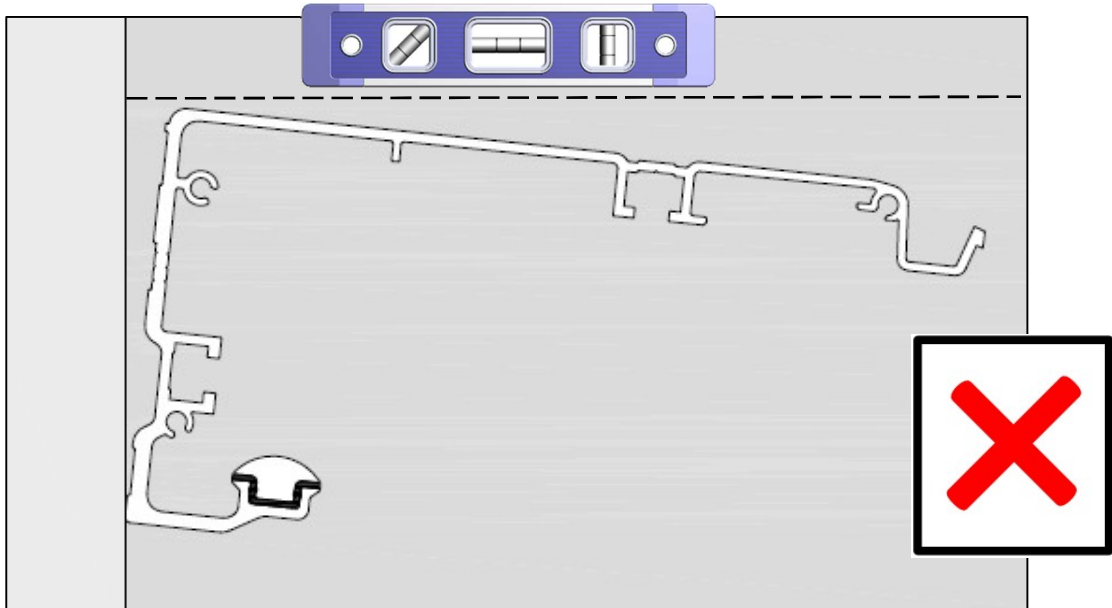

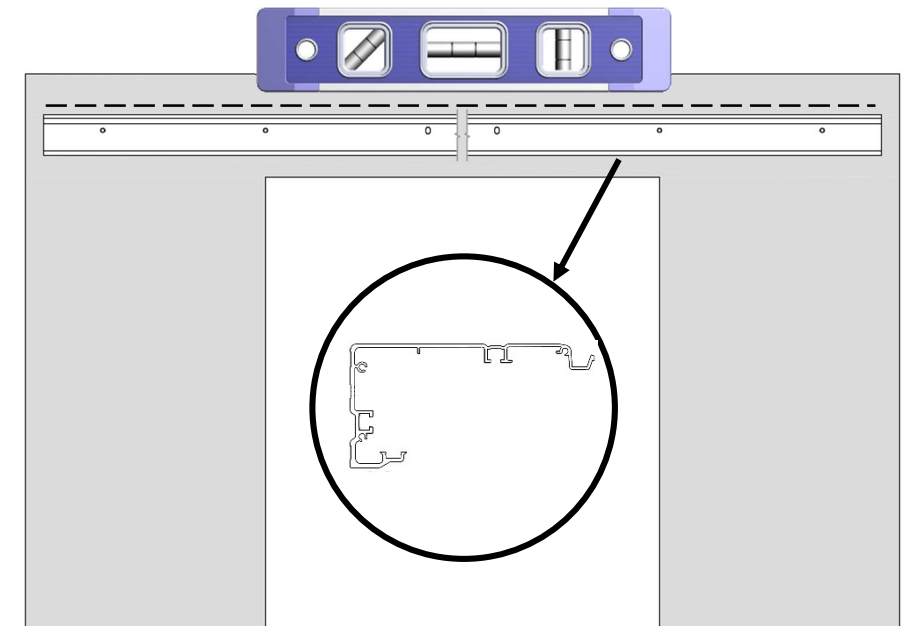
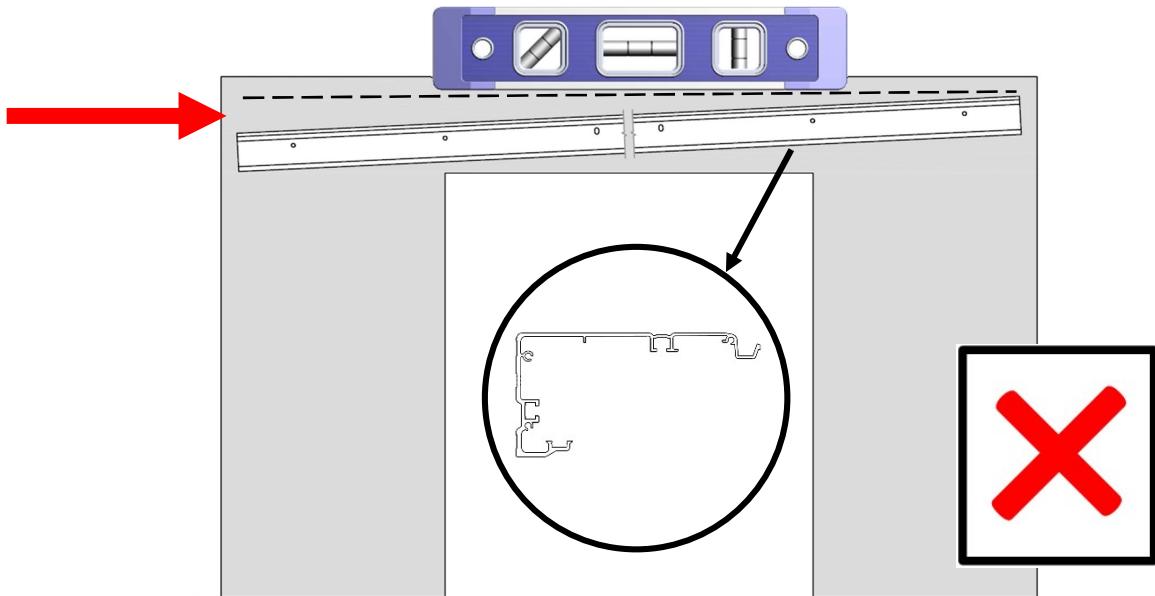
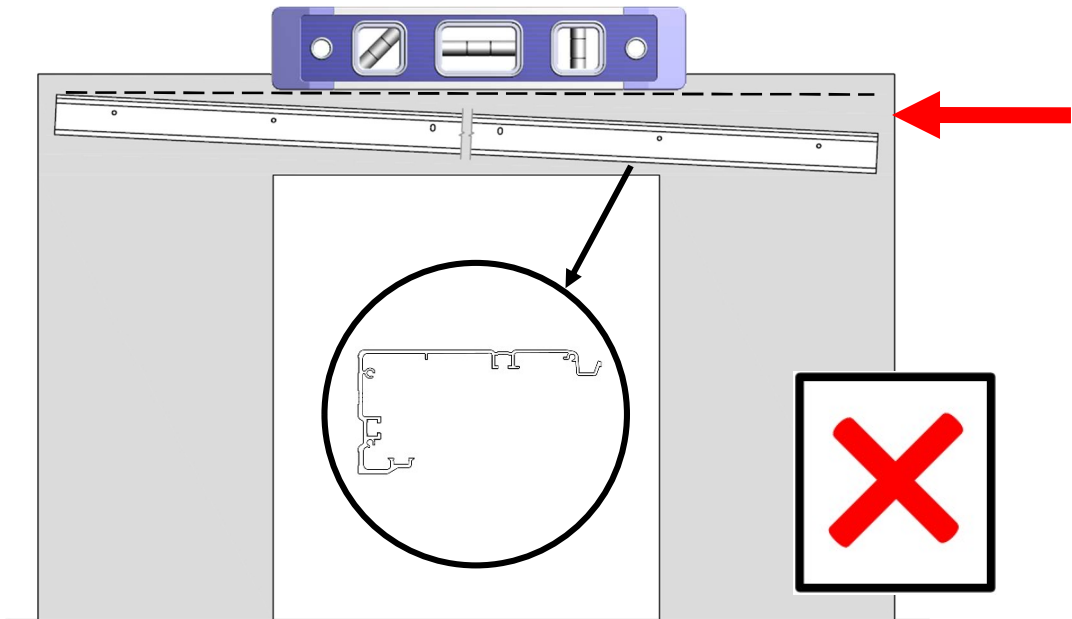



The track must not follow the deformations of the wall, Insert spacers in the fixing points to maintain straightness

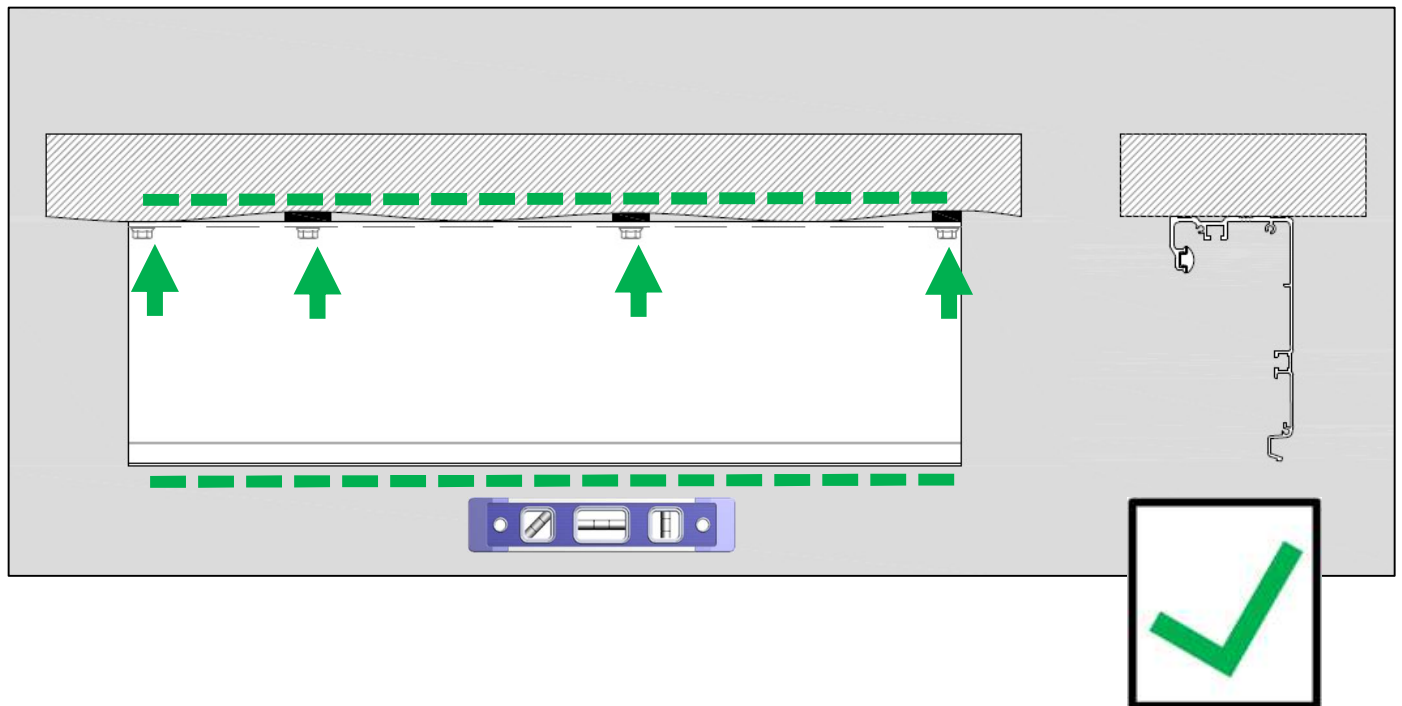
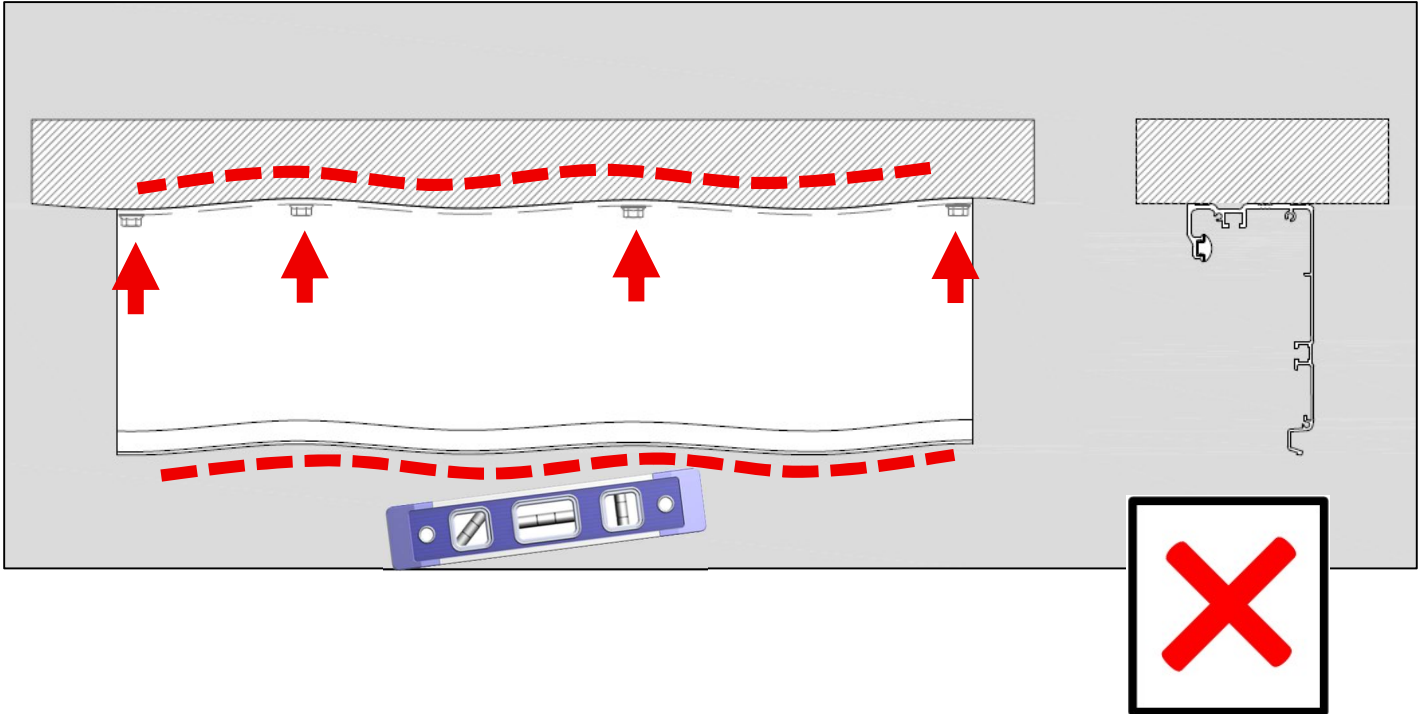



The track must be fixed using all the slots/holes provided in the aluminium.

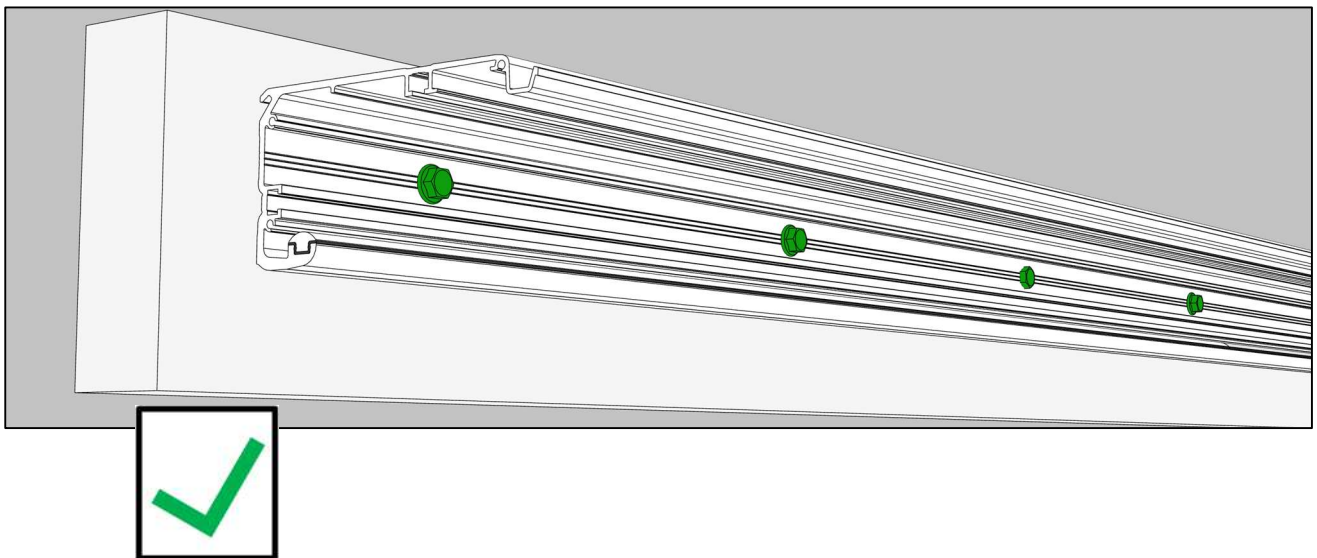
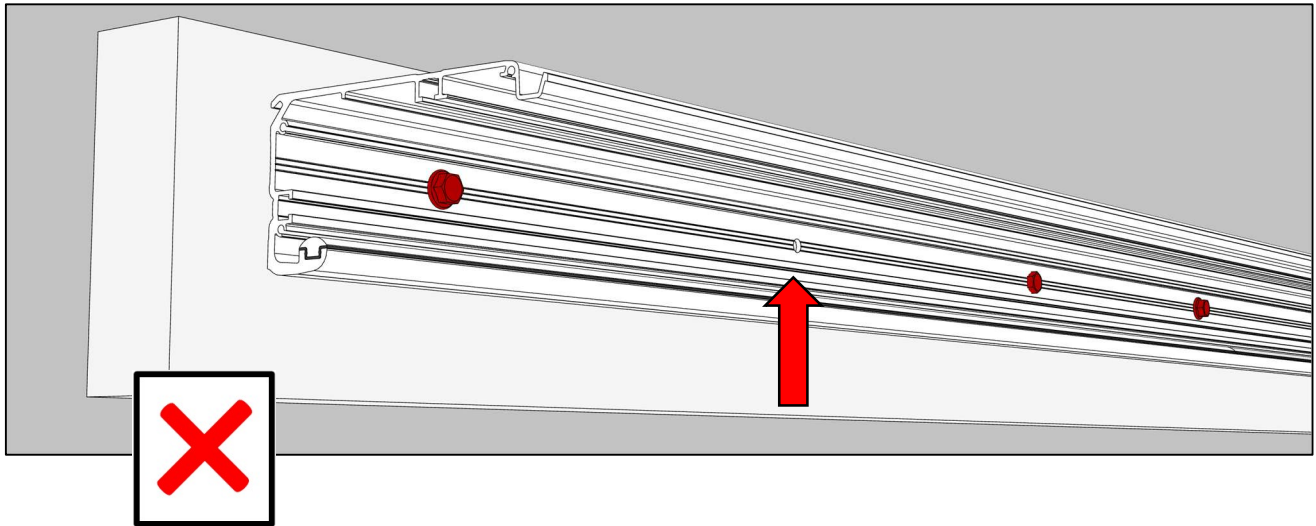

After attaching the track to the wall, replace the disassembled/moved components in their original position (refer to the reference marks made earlier).

6.2.5. CARRIAGE INSTALLATION

6.2.5.1 CAPACITY

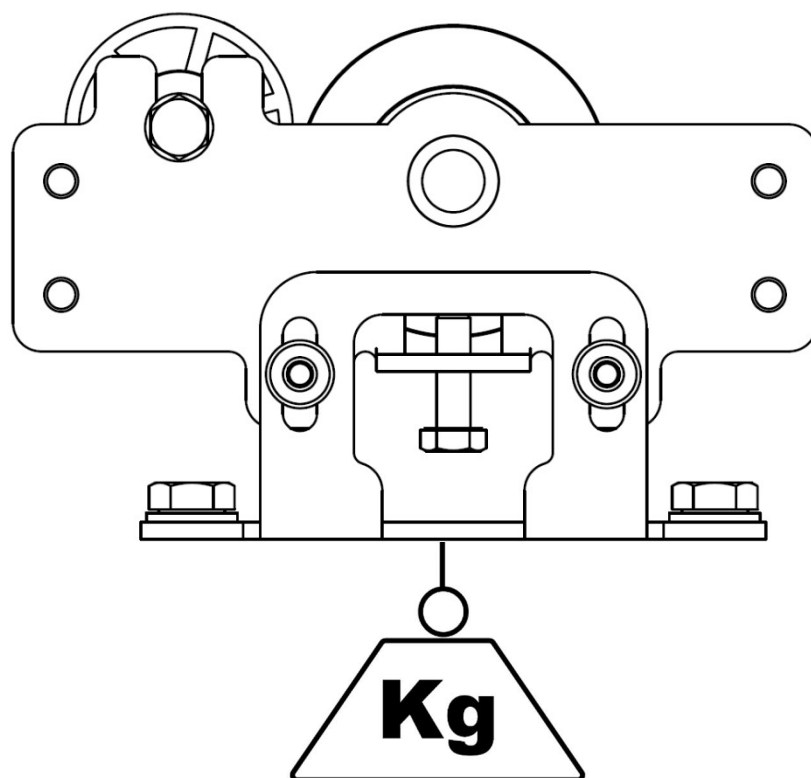

Max capacity 27.5Kg/trolley

6.2.5.2 INSTALLATION OF CARRIAGES ON WING

- Fixing:**
! Fix the carriages on the doors using the appropriate M8 screws.
- Note 1:**
! The dimensions shown in the picture refer to wings seen from the inspection side of the operator (cover side).
- Note 2:**
! For doors equipped with a breakout panic device or glass doors frameless, follow the assembly dimensions given in the manuals of the relevant accessories.

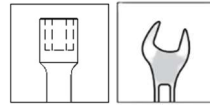
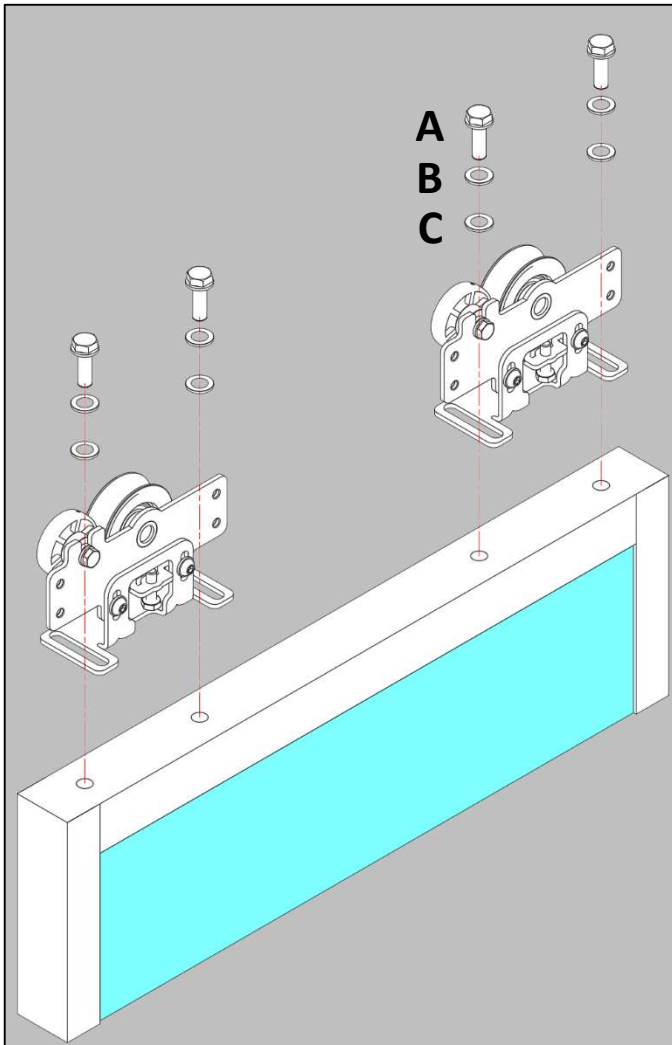

13 ÷ 20.41Nm

A	Hex Head Screws M8x1x16-25
B	M8 serrated washers
C	Plane Washer M8

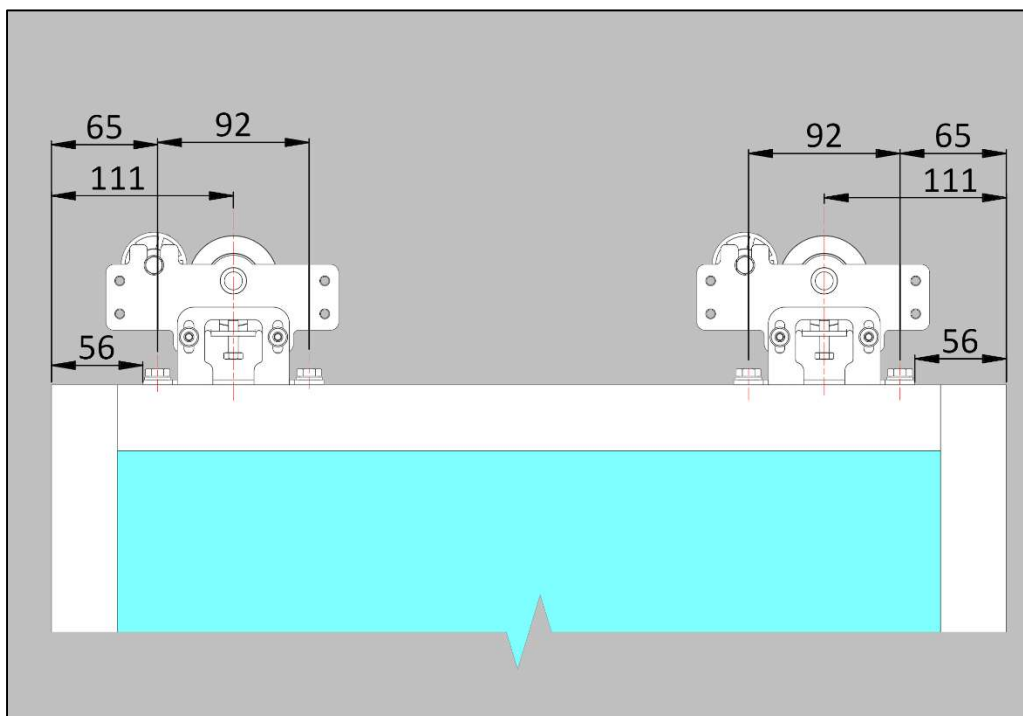

6.2.5.3 POSITIONING OF THE DOOR IN THE TRACK

Lower the anti-derailment wheels completely.

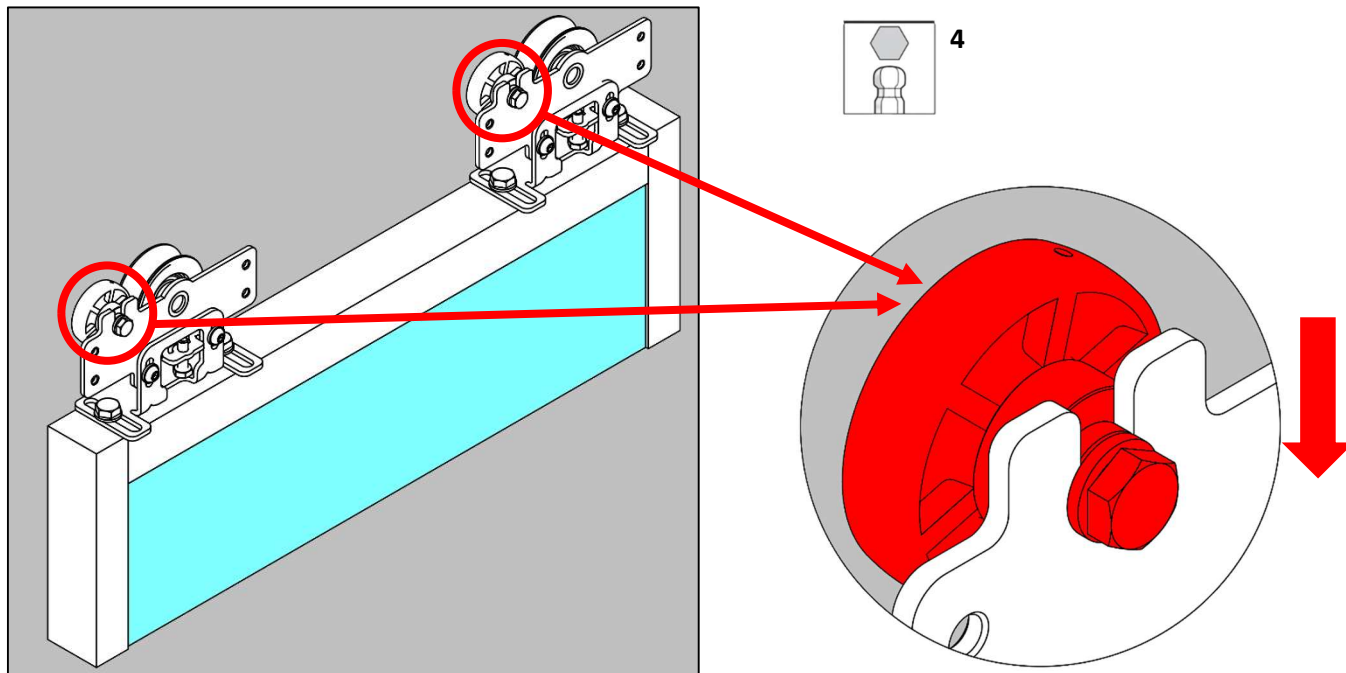

Lift the door and gently position the wheel of the carriages on the sliding guide, taking care not to damage parts with violent impacts.

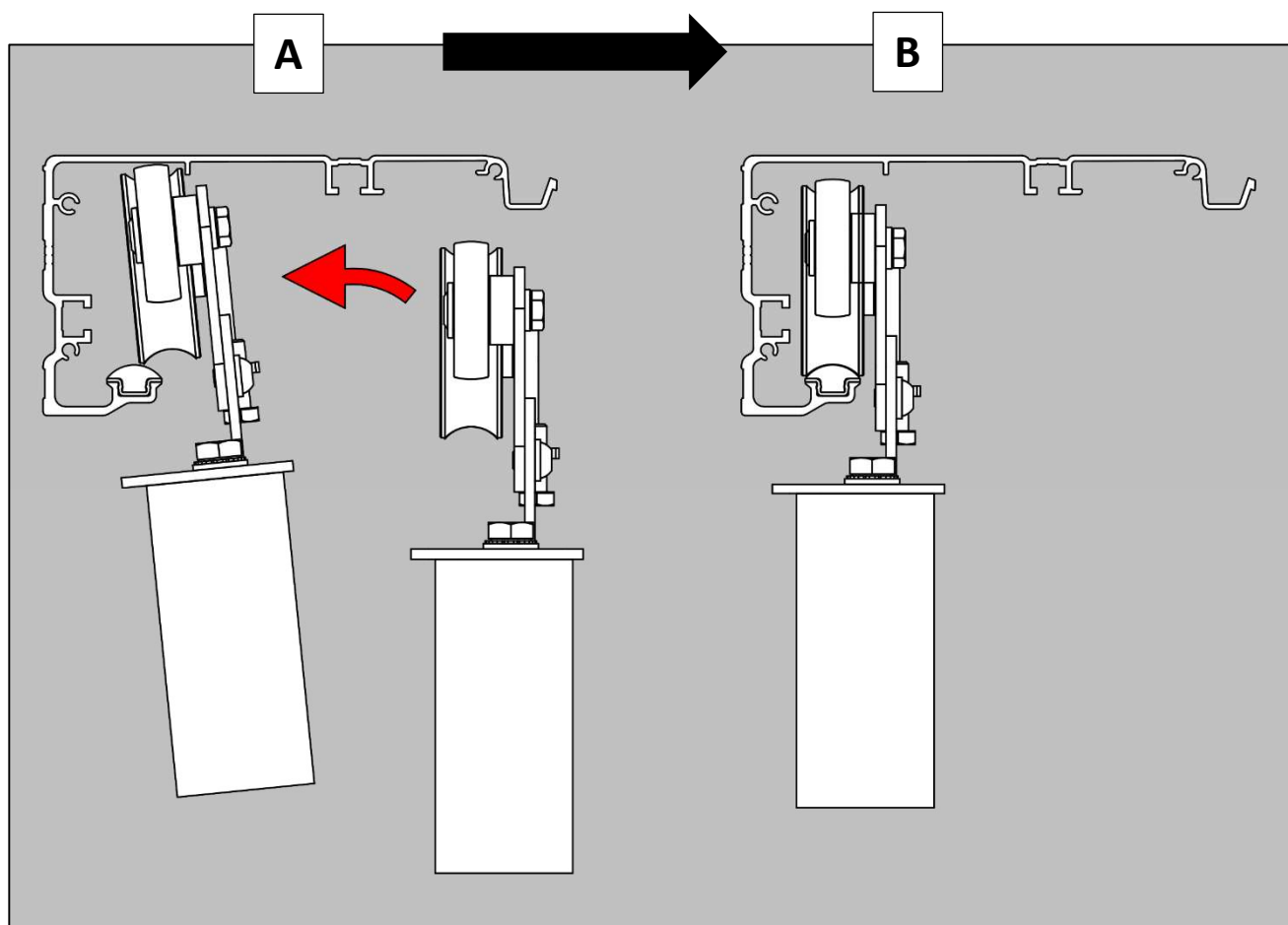

6.2.5.4 DOOR ADJUSTMENT

The wings can be adjusted separately on the two axes (y, z) depending on the installation requirements.

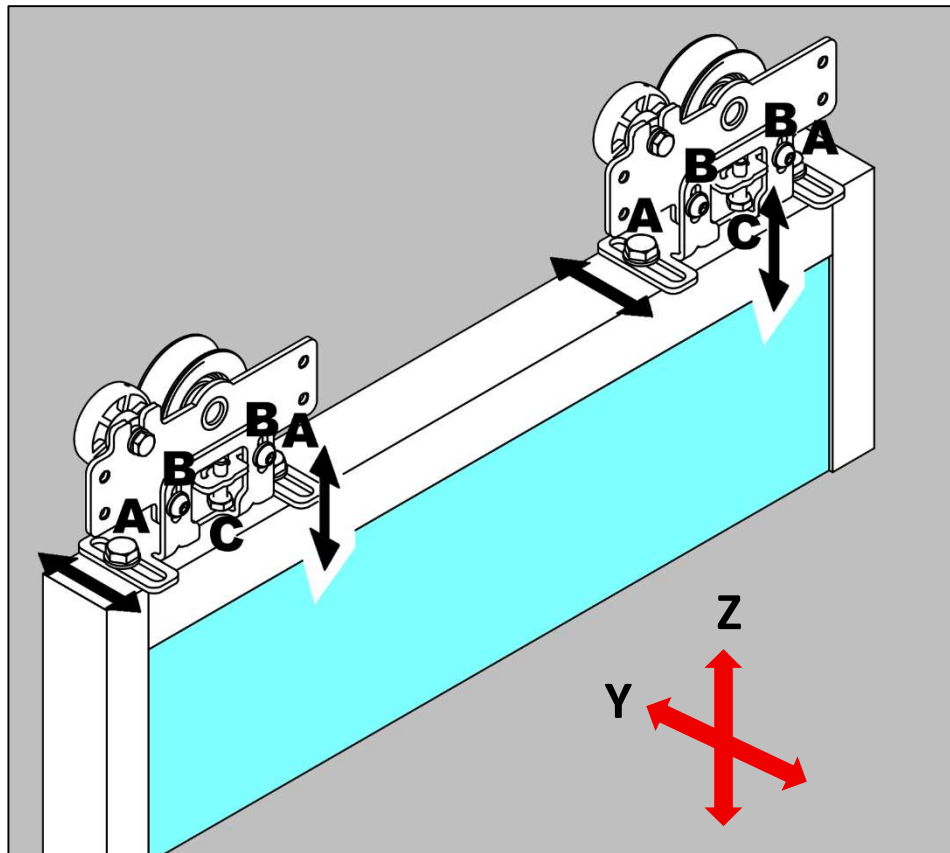

Transverse adjustment (Y): Loosen the fastening screws A and move the wing in the Y direction until it reaches the position necessary for correct operation.

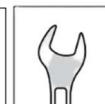
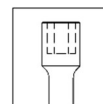
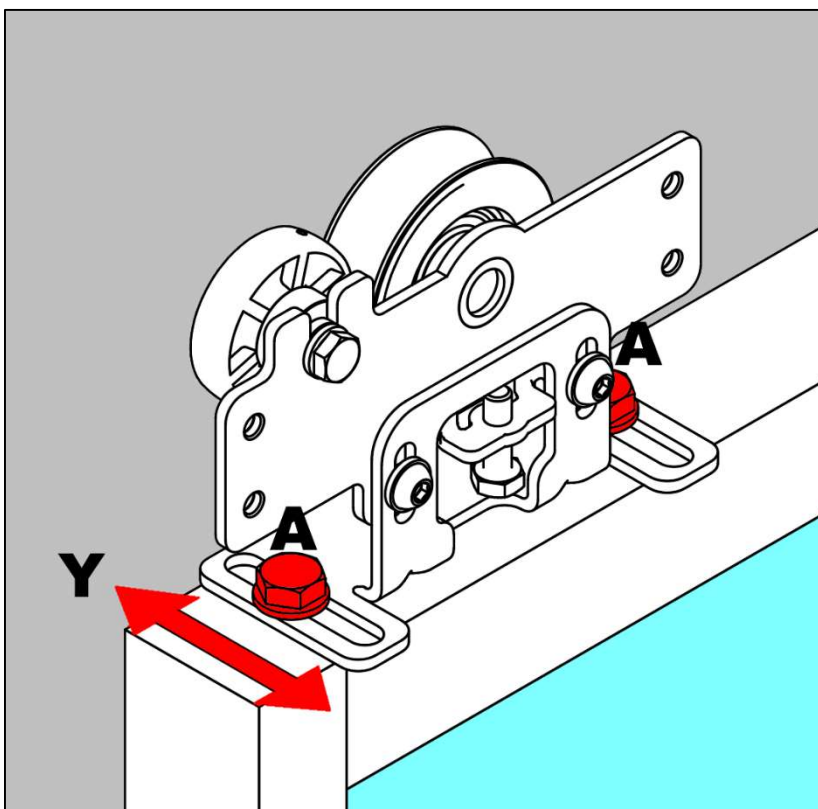

13 ÷ 20.41Nm

Pay attention to the correct alignment of the carriages and their parallelism with respect to the sliding guide. To check the correct alignment, simply make sure that the "E" dimensions measured between the wing and the carriage coincide for all carriages on both the left and right sides. As further proof of correct alignment, move the doors manually: sliding must take place with minimal effort without any type of impediment or abnormal friction. With the wings in the correct position, tighten the screws A progressively and alternately until they are completely tightened.

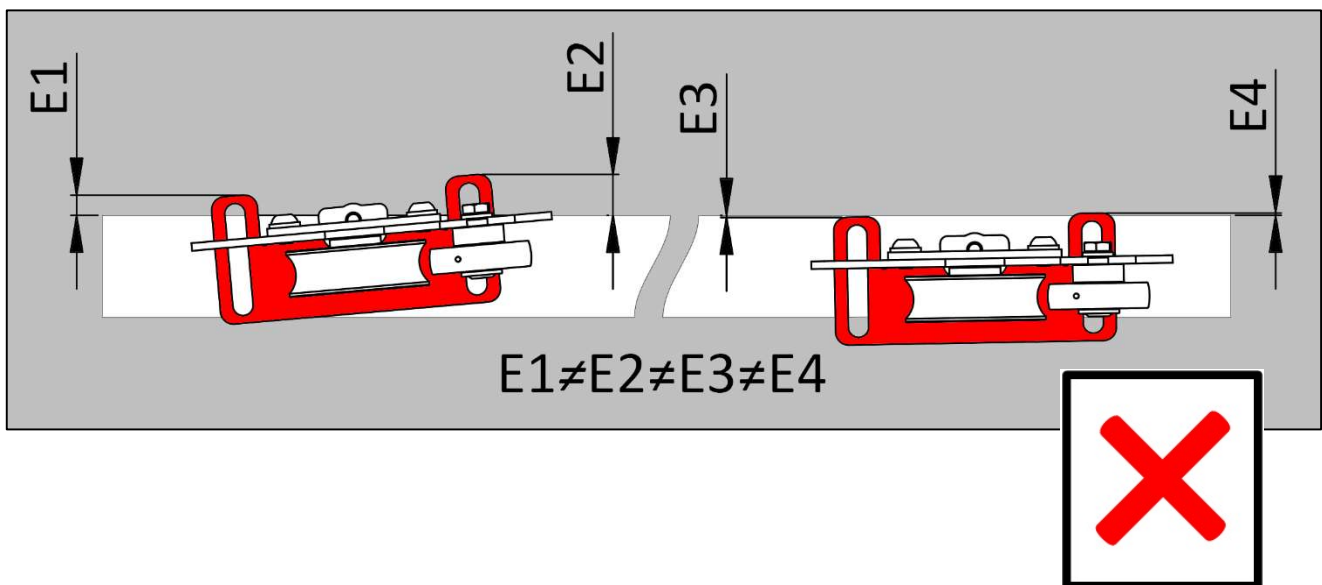
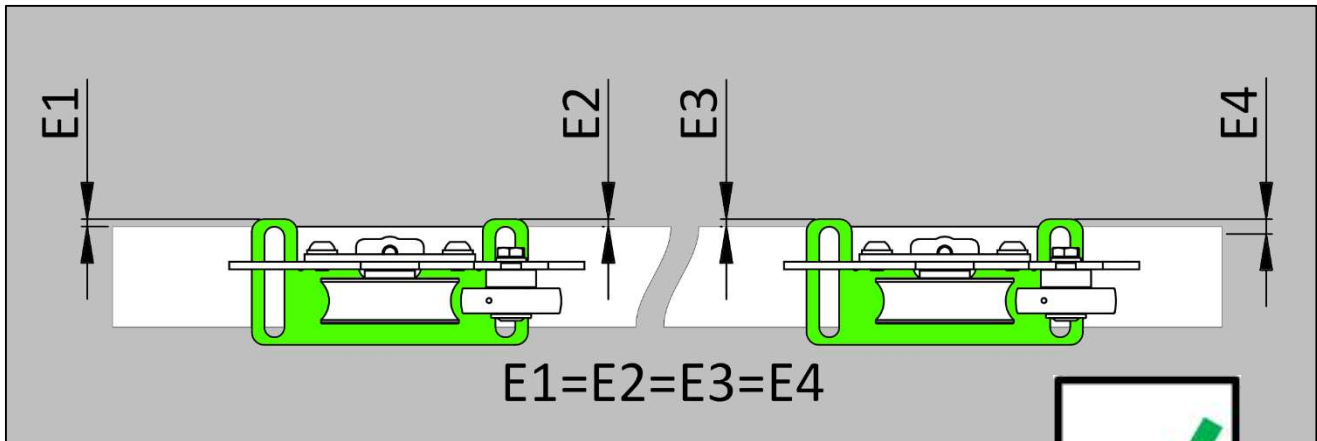

Turning screw A during tightening may cause the carriage to become misaligned. To avoid this inconvenience, tighten the screws progressively and alternately A. Misalignments between the carriages and the sliding guide can cause wear, excessive noise and malfunctions of the operator.

Vertical adjustment (Z): To adjust the door, follow these steps:

1. Loosen the screws B slightly.
Do not completely unscrew the screws B to prevent the door from falling completely.
2. Use the C-level screw to adjust the height of the wings.
3. Tighten the screws G securely, taking particular care not to alter the alignment obtained.

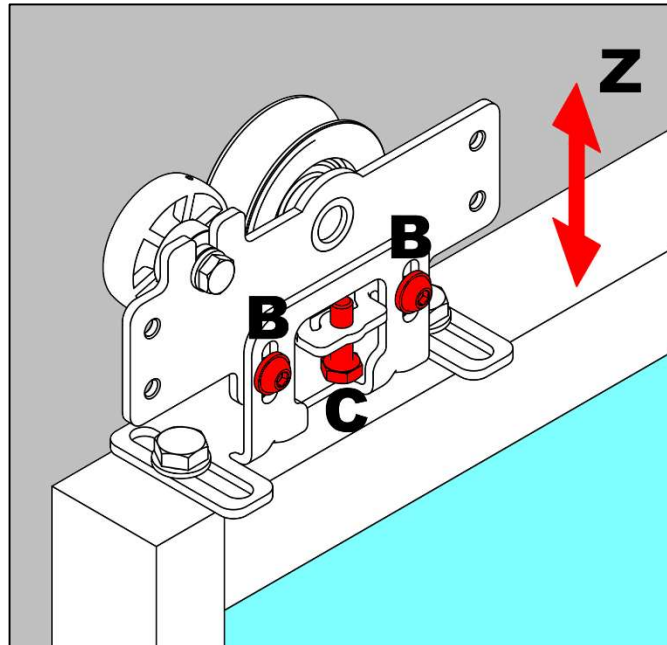
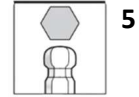

6.2.5.5 COMMISSIONING OF CARRIAGES

Adjust anti-derailment so that the roller wheel is not in contact with the aluminum profile during sliding, maintaining a clearance of 0.5 ± 1 mm. Tighten the screw without altering the chosen setting.

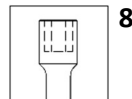
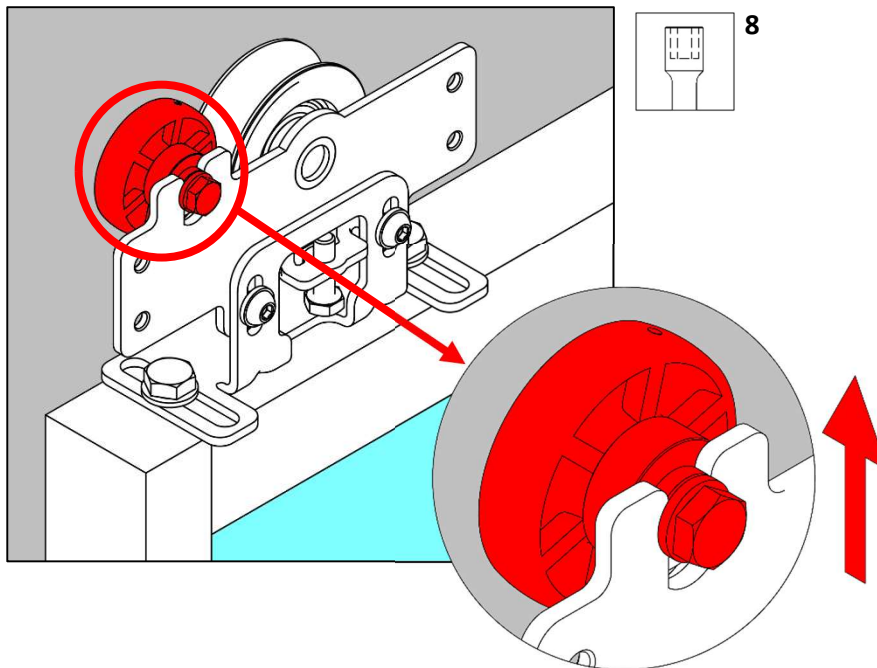

Incorrect adjustment of the derailment device that brings the wheel into contact with the aluminum profile causes excessive wear and noise during operation.

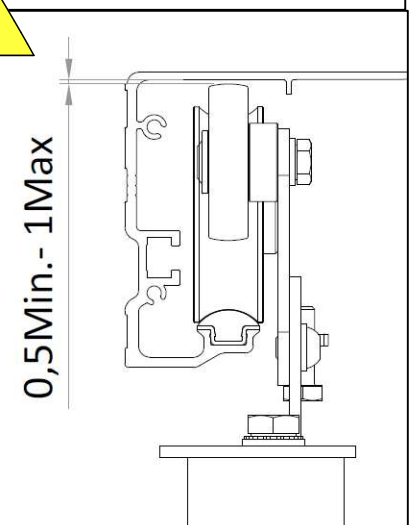

Once the anti-derailment has been adjusted, carefully check that all the screws on the carriages are correctly tightened.



Poorly tightened carriage screws can unscrew, causing parts to come off, the sashes fall or the belt to detach, with the possibility that the sash may be out of control when it is in motion and constitute a serious source of danger.

6.2.6. FINAL ASSEMBLIES

Once the crossbar has been fixed and the wings have been fitted, carry out the last mechanical assembly operations as follows:

1. Reassemble, **in the positions previously indicated**, the components moved during the fixing of the enclosure to the wall.
2. Reassemble and re-tension the belt (if it has been disassembled):
3. Attach the belt clamp to the carriage(s) following the instructions below:

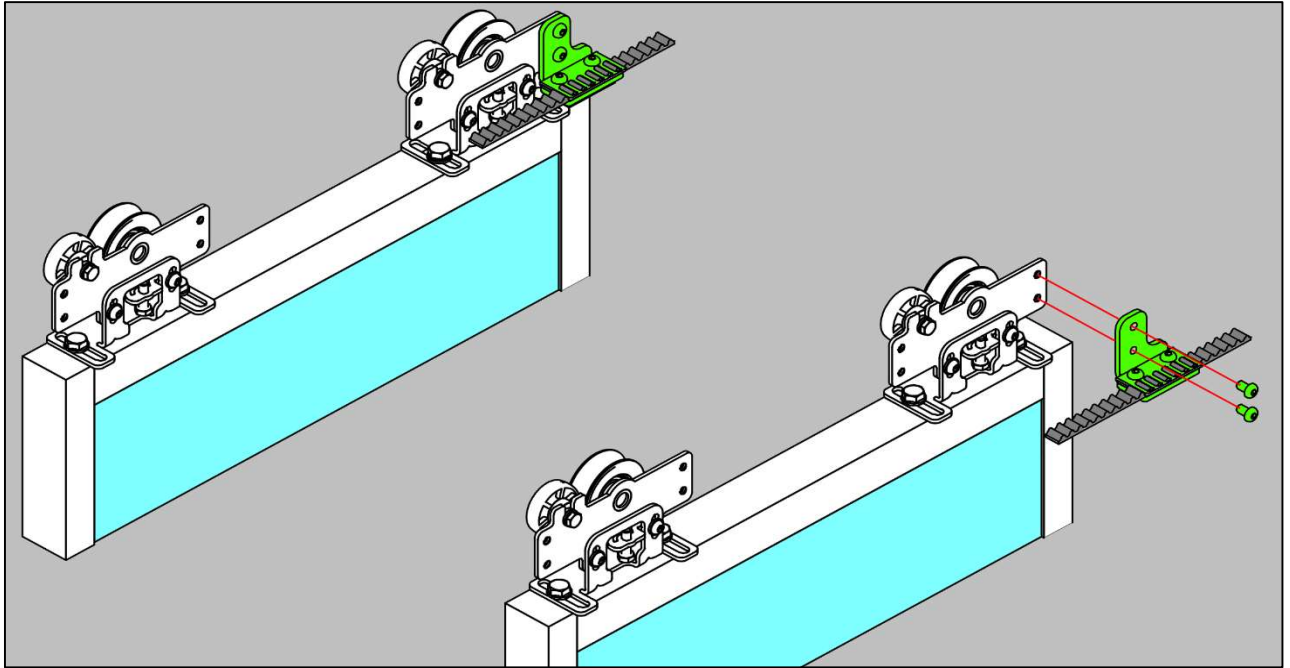

 4 – 10,3Nm - Screws TBEI M6x10

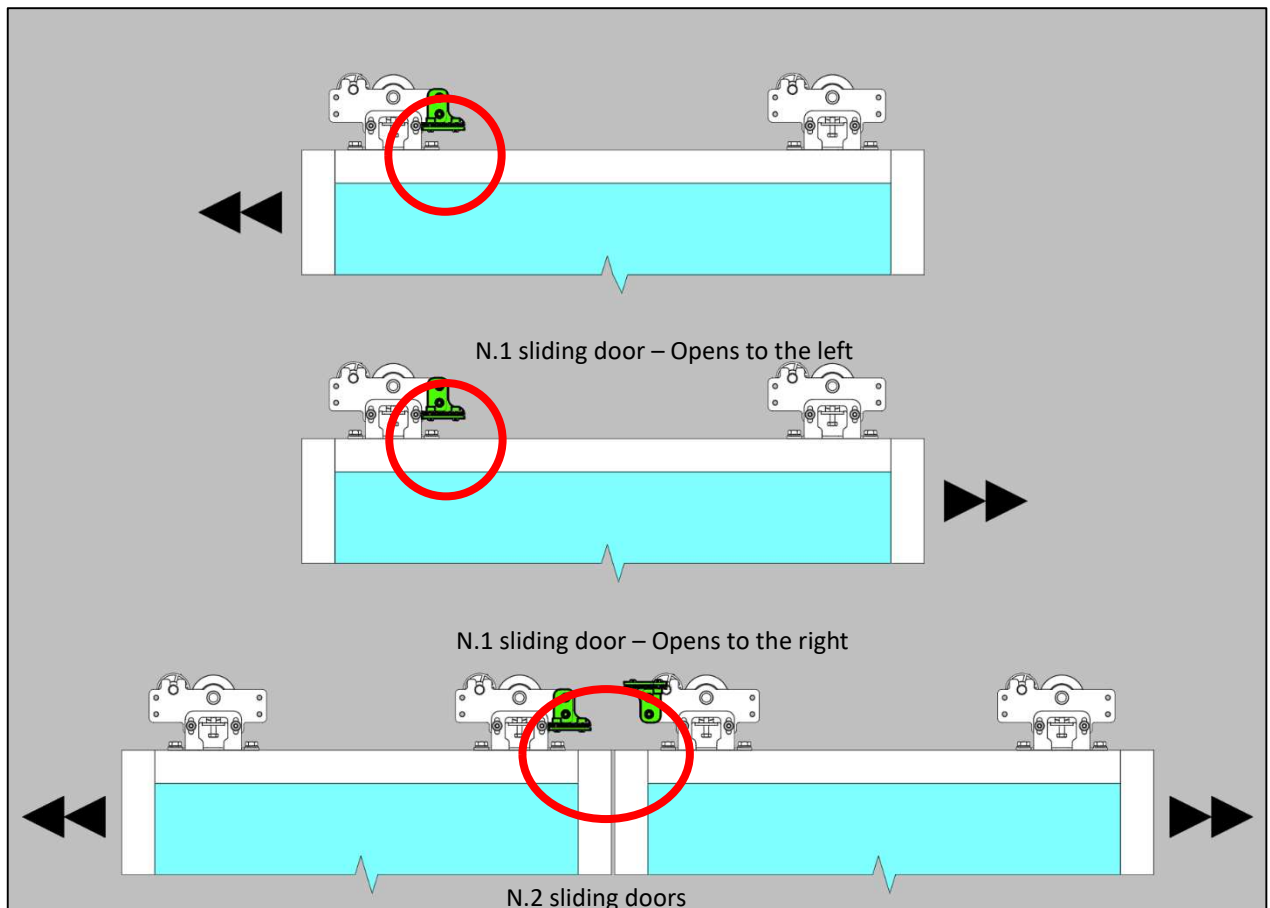

4. Adjust the limit switches with the doors:

- N.1 sliding door (Left-Right): slightly loosen the screws "A", bring the door to close first and move the limit switch until it touches the pad on the carriage, then tighten the screws "A". Repeat the same operation by opening the door.
- N.2 sliding doors: slightly loosen the screws "A", bring the doors to close first and move the limit switch until the pad on the right carriage touches, then tighten the screws "A". Repeat the same operation by bringing the doors open.



Before starting the operator, check that the screws "A" of the limit switches are correctly tightened

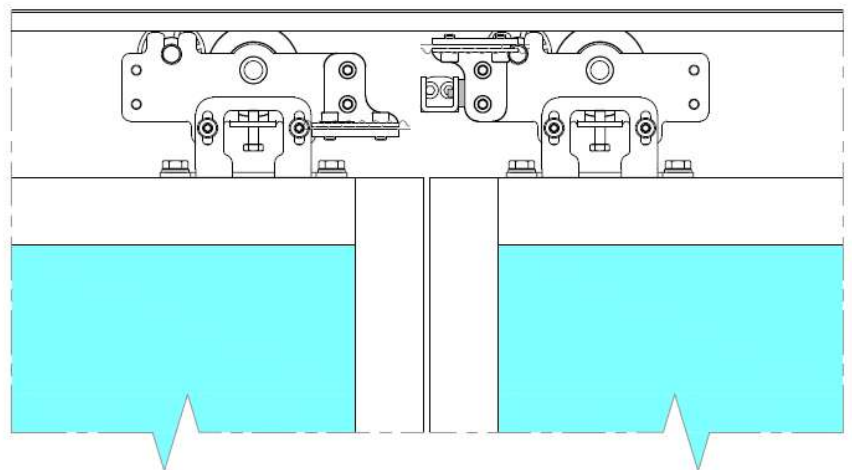
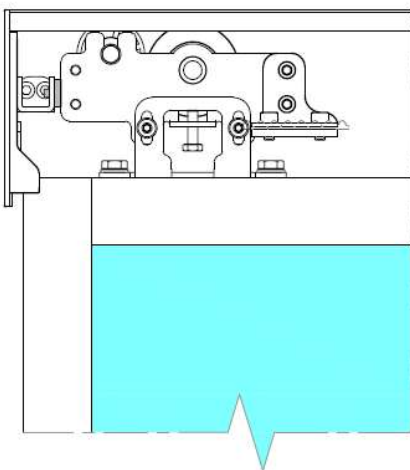
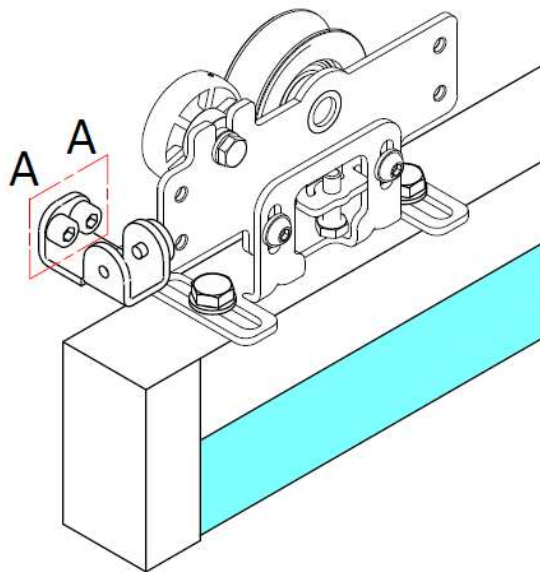

5. Close the cover by repeating the steps on page 16 but in reverse.

7. FINAL CHECKS MECHANICAL ASSEMBLY

Before starting the operator, check and perform the following operations:

- Carefully remove any dust or chip residues from the runway and carriage wheels
- check the correct tightening of the screws of all the components of the operator
- check the correct belt tension
- check that the wiring harnesses are fixed and there are no cables running near the sliding area of the carriages or the belt
- Check that the limit switches are correctly positioned and that the belt clamps do not come into contact with the toothed pulleys
- If necessary, spread a light film of common bearing grease on the runway and on the drive belt



The sliding rail and the transmission belt can work without lubrication without wearing phenomena. However, light lubrication prevents noise from occurring if there is no perfect alignment between the parts.



For correct operation, it is very important that there are no mechanical impediments or friction that hinder movement throughout the sliding area of the doors: if in doubt, perform a manual handling test with a dynamometer to identify any points with excessive friction and eliminate them.

7.1 CONNECTIONS AND COMMISSIONING



For mains connections, all accessories and commissioning, use the POWERCORE electronic manual.

8. USER MANUAL

Recipient and use of the manual:

These instructions are intended for the operator or user of a SESAMO POWERCORE SERIES automatic door system. In order to obtain the best performance from the operator, Sesamo recommends that you read and carefully follow the instructions for use in this manual. This device is designed for the automation of sliding doors. Any other use will be considered contrary to the intended use by the manufacturer who, therefore, cannot be held liable. Do not tamper with or alter the internal equipment of the automation system and all the safety devices provided in the control unit for any reason. The manufacturer declines all responsibility if internal parts of the operator are altered or tampered with or safety devices are used in the system other than those indicated by the manufacturer itself.

Operation Description:

the opening of the wings can be controlled by detection sensors, selectors (see functionality depending on the selector installed) and buttons for manual control;

The opening cycle can be followed by a stop or automatic reclosing depending on the chosen logic.

The stop of the wings in the open position facilitates the passage of people according to the customer's needs, the dwell time can be adjusted at the time of installation.

The doors close automatically at the end of the parking time, with a slower speed than opening.

The safety of the automation is entrusted to the active safety sensors that detect the presence of any obstacles in the sliding area and possibly prevent the reclosing of the wings.

As an additional safety, the operator is equipped with a sophisticated microprocessor device that limits the pushing force of the wings in the event of danger, so as not to be a source of danger for people in transit.

For safety reasons, the operator is designed so that it is always possible, even in the absence of mains and battery, to move the wings manually after unlocking the door locking device if installed with the appropriate key.

Logics – Logic selection:

To select the logics described, follow the explanations in the following paragraphs based on the selector switch installed (rotary, Icon, Digidor). The meaning of the logics is as follows:

- **Automatic:** The door works in entry and exit mode automatic.
- **Exit Only:** The port operates in exit-only mode. Any electric lock device, if installed, locks the movement of the wings in the closed position.
- **Stop closed:** the doors remain permanently closed Any electric lock device, if installed, locks the movement of the wings in the closed position.
- **Stop open:** the doors remain permanently open.
- **Manual:** the automatic opening controls are deactivated and the door can be moved manually.
- **Patial opening only exit:** The door operates in exit only mode with reduced opening.
- **Automatic partial opening :** the door operates in entry and exit mode with reduced opening.
- **Partial opening in Stop Open:** The door operates in entry and exit mode with reduced opening.
- **Settings menu:** for calendar setting or adjustments. [See Digidor manual](#)
- **Diagnostics menu:** to view the input diagnostics. [See Digidor manual](#)



For specific functions other than the basic functions, check the manual of the selector installed.

Range of operating logic selectors:

Rotary:

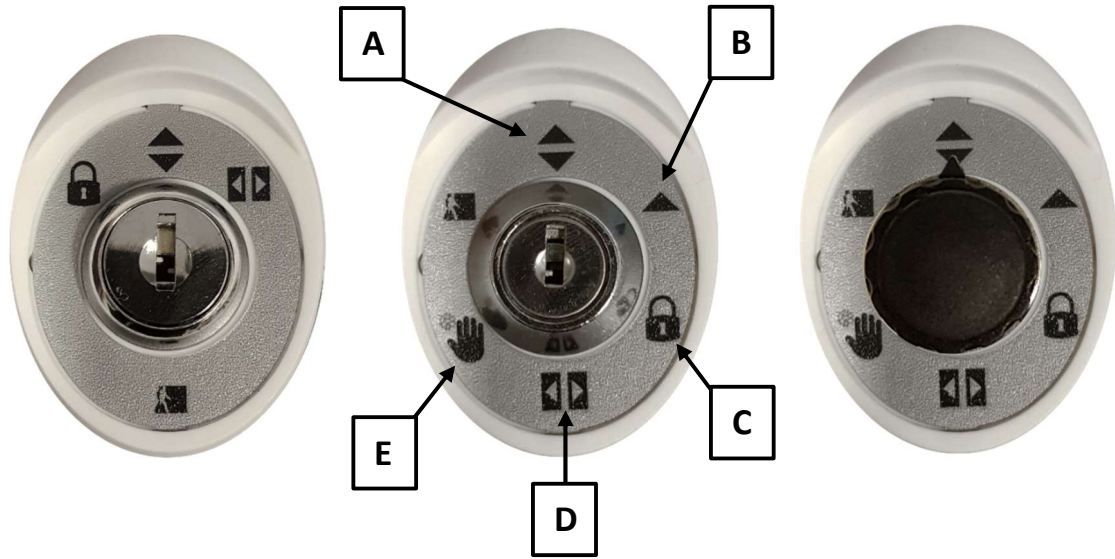

- A. Automatic
- B. Exit Only
- C. Stop closed
- D. Stop open
- E. Manual

RESET

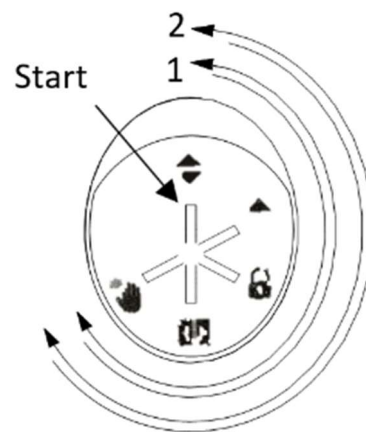
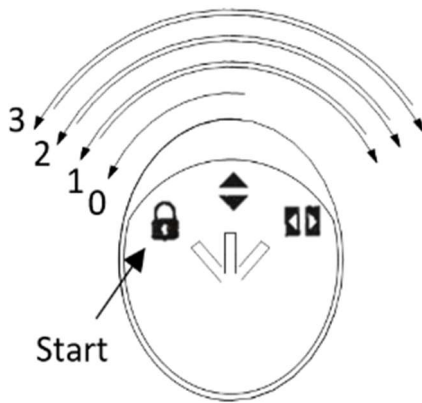

- 0. Automatic
- 1. Exit Only
- 2. Stop closed
- 3. Stop open

Icon:

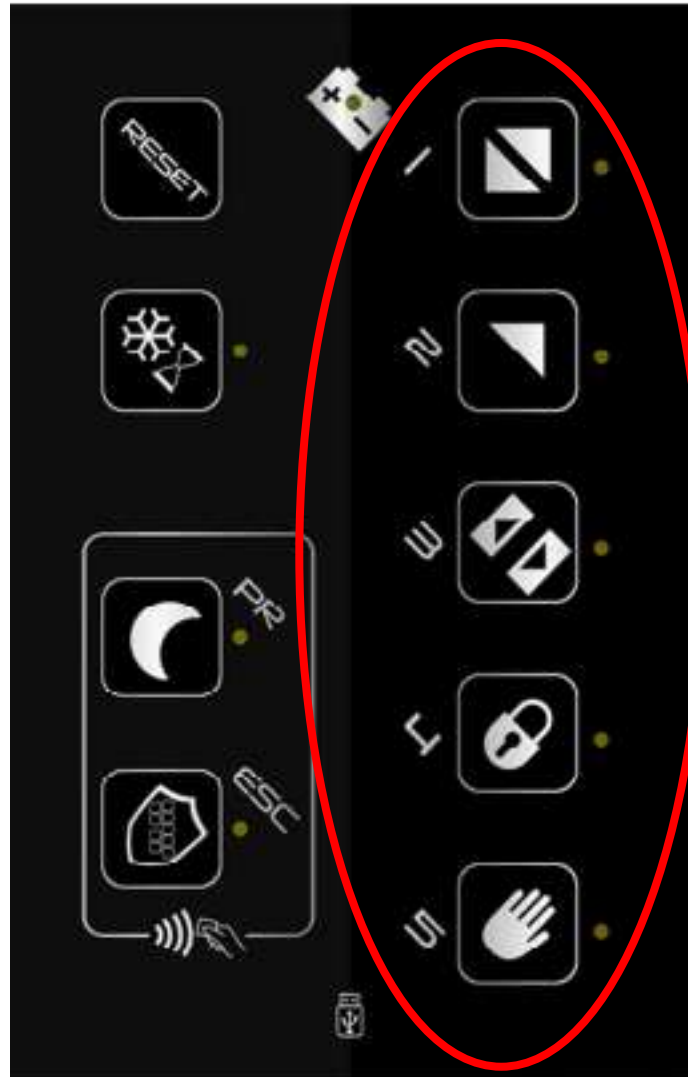

Settable logic list:

1. Automatic
2. Exit only
3. Stop open
4. Stop closed
5. Manual

Actions to be performed in order to set the chosen logic:

1. Place your finger in the desired key area for 1".
2. You will hear 1 beep.
3. The LED will light up steadily.
4. Set logic.

Service key functionality:

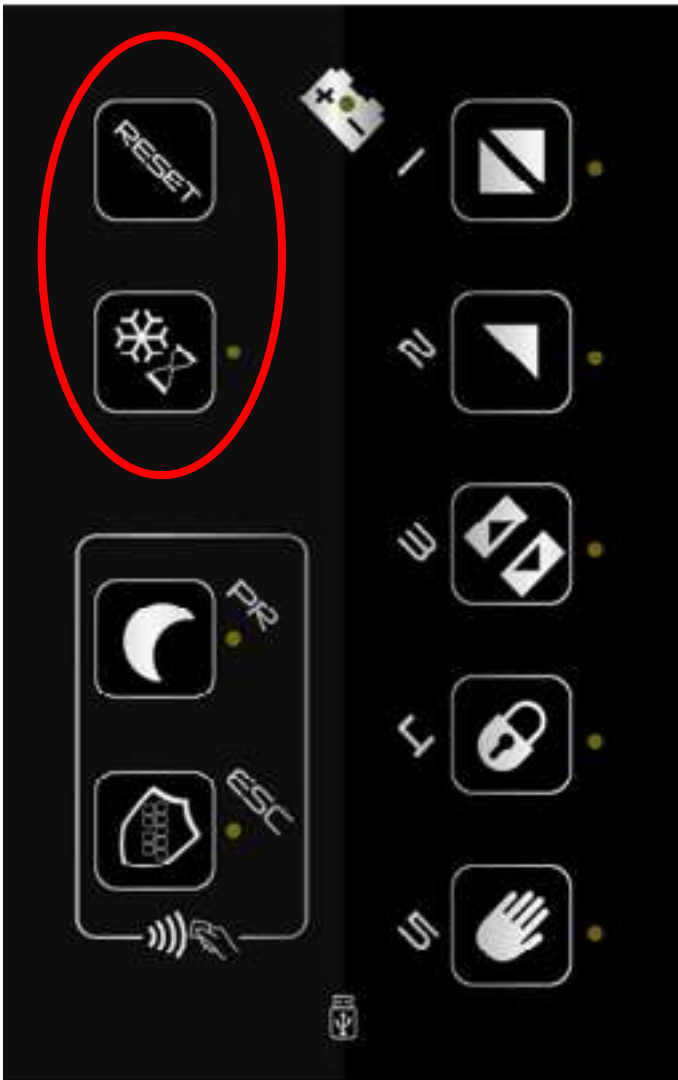
**Read the warnings carefully!!!**

1. In case of partial opening selection with the Open Stop logic already active, it will be necessary to have the automation perform a complete cycle to make the partial opening settings active.

2. In case of Reset, the partial opening is deactivated, unless a logic after reset is set (via Digidor) that requires it.

3. The closed stop logic is the only logic that cannot be combined with the partial opening.





RESET – by resting my finger for 3" I send a reset to the card



For sliding: by resting my finger (1 beep plus fixed LED) I combine the "partial opening" logic with the Previously preset (on the selector I will find two LEDs on, one on the logic and the other on the snowflake icon)







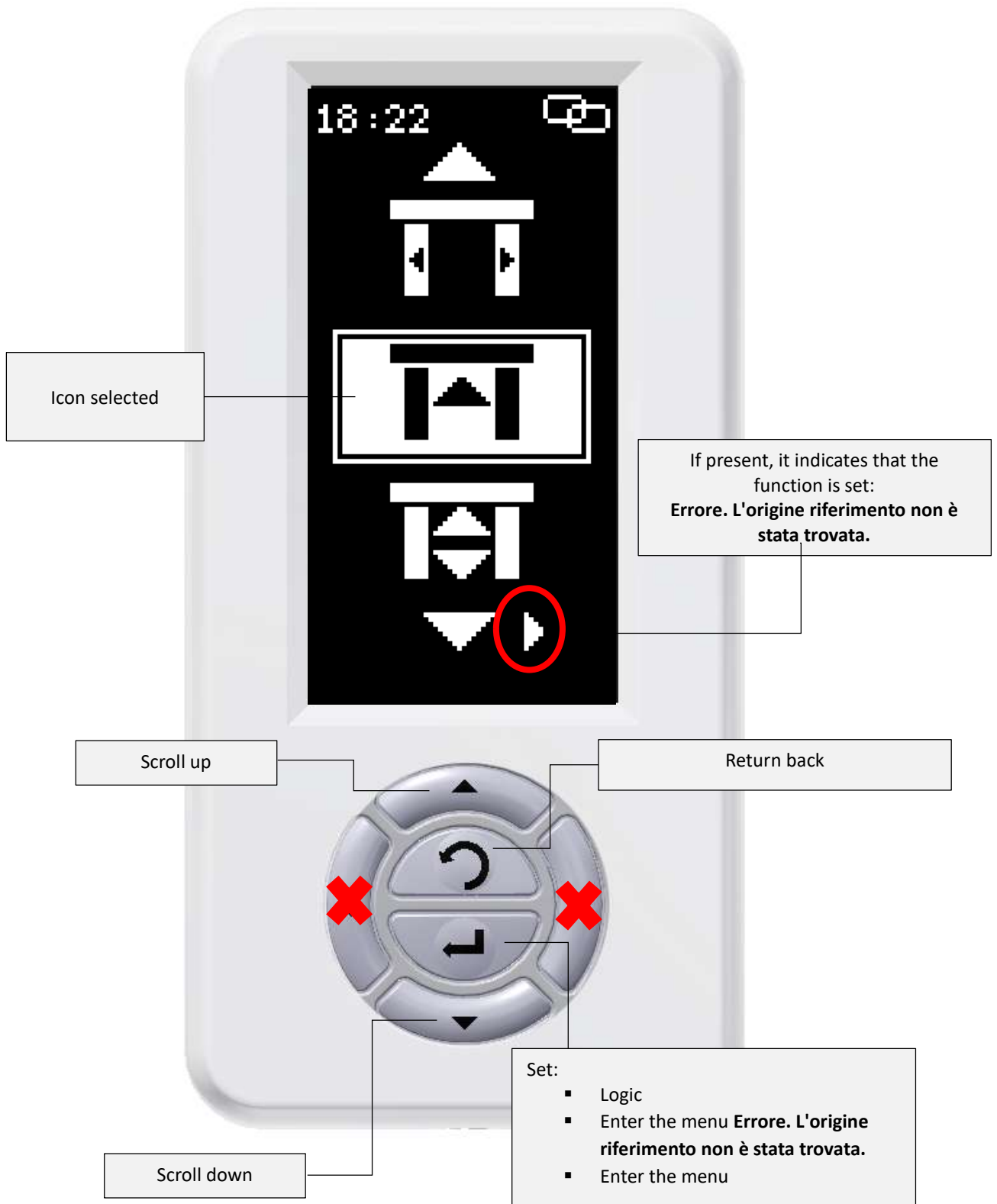





For Swing: not applicable

Digidor:

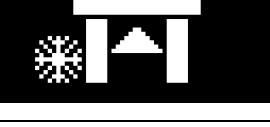

List of menu icons:

Sliding doors:

ICONS	DESCRIPTION
	Stop closed
	Stop open
	Exit only
	Automatic
	Partial Opening in Exit Only
	Automatic partial opening
	Partial Open in Stop Open
	Manual
	Manual partial opening
	Settings menu Errore. L'origine riferimento non è stata trovata.
	Diagnostics Menu Errore. L'origine riferimento non è stata trovata.

Manual Unlocking:

For safety reasons, any Electric lock device of the wings is equipped with a manual release control. It is provided in the two versions explained below.

Manual release (already standard on all Electric locks):

The unblocking is obtained by proceeding as follows:

1. Insert a screwdriver into the release hole on the cover (the hole is identified by a special sticker.)
2. Push the screwdriver until it reaches the internal lever pre-installed on the block.
3. Operate the lever by exerting upward pressure
4. At the same time, open the doors manually.

Reference Image:

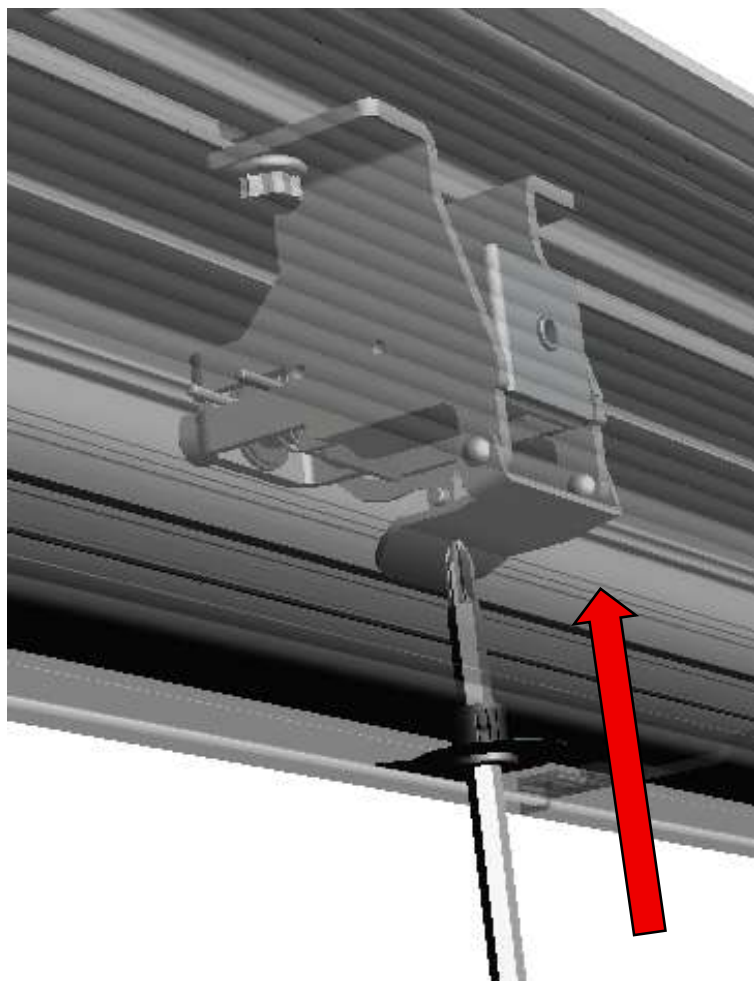

Lever release:

The release is obtained by acting on the special lever handle installed near the system or on one of the heads of the automation, the operation on the release handle allows the wings to be moved manually. By repositioning the handle in the initial position, the Electric Block returns to lock the doors.

The release mechanism should be checked periodically to prevent looseness, dirt, wear, corrosion, or other unforeseen causes from preventing it from working properly.

Electronic key/key selector:

Through this accessory, together with the electric lock device, it is possible to close the doors from outside the room, regardless of the logic selected on the basic or advanced selector. Any lack of network after this closure will not open the doors

Each time the electronic key is inserted, the automatism switches from a normal operating condition to a locking condition and vice versa. During the transition from the locked to normal operating condition, the wings perform a complete opening and closing cycle so as to allow a person to enter.

Cleaning:

Subject	Mode
Painted surfaces	Cleaning with soap and water
Anodized surfaces	Cleaning with non-alkaline soap and water (pH 5.5/7)
Selectors	Cleaning with a damp cloth
Sensors	Cleaning with a damp cloth

Maintenance intervals:**Maintenance:**

The maintenance interval is determined according to the intensity of use of the automation and the conditions of use. Servicing should only be performed by a qualified technician. Each maintenance must be noted in a log book. See application example contained in Annex A of this manual.

In traffic-intensive installations (entrances to airports, supermarkets, shopping centers, refreshment areas in motorway rest areas, etc. greater than 200 cycles/day) or operating in particularly harsh conditions (exposure to corrosive agents, proximity to the sea, very windy areas, doors subject to frequent collisions with moving objects such as supermarket carriages, etc.) Scheduled maintenance should be carried out at **six-monthly intervals** by a specialized technician.

In low-traffic facilities (small businesses, private offices, homes, operating theatres, etc. up to a maximum of 200 cycles/day) it is advisable to carry out scheduled maintenance at annual intervals by a specialized technician.

9. MAINTENANCE MANUAL

During a scheduled maintenance intervention, carried out by a specialized technician, it is necessary to carefully carry out the following checks and procedures:

- ❑ Cut off the mains power supply using the two-pole switch upstream of the operator. If the operator is equipped with batteries, the doors may open and remain open.
- ❑ Make sure that the two-pole switch installed upstream of the automation system intended to disconnect the power supply is visible from the operating point of the door on which you are working. If it is not, it is necessary to implement a safeguard system that ensures that voltage is not reactivated unintentionally
- ❑ Open the automatic mechanism by disassembling the cover.
- ❑ Disconnect the batteries
- ❑ Check the tightness of the screws of the carriages and the components installed inside the track.
- ❑ Check the wiring connections between the accessories, sensors and the control unit.
- ❑ Clean the runway with a cloth (No cleaning products) and check its integrity.
- ❑ Check the smoothness of the door frame, its general condition (evaluate any out-of-square caused by impacts) and above all that there is a minimum space of 5 mm between the floor and the wing. In order to ensure correct sliding even in the event of strong thermal expansion of the door frame.
- ❑ Clean the wheel of the carriages and check them for wear, replace them if necessary.
- ❑ If necessary, grease the sliding rail with a thin layer of bearing grease.
- ❑ Check the state of wear of the drive belt and grease it if necessary.
- ❑ Check the limit switches for wear, and replace and adjust them if necessary.
- ❑ Check the floor guide and proper functionality and, if necessary, grease or replace it.
- ❑ Check the correct operation of the electric lock, manual release and manual reset. If necessary, lubricate the release cable.
- ❑ Reconnect the batteries, close the operator cover, reconnect to the mains power supply
- ❑ Check the safety sensors (functionality and adjustment).
- ❑ Check the opening sensors (functionality and adjustment).
- ❑ Check the movement of the wings when braking and approaching.
- ❑ Check that the operating logic has been correctly selected.

C187740_00_MAN_PL55_EN_15_04_26



SESAMO srl
Str. Gabannone, 8/10
15030 Terruggia (AL) Italy
Tel: +39 0142 403223
Fax: +39 0142 403256
www.sesamo.eu
e-mail: info@sesamo.eu

Annex A

MAINTENANCE LOG

Description of the intervention

Installation Start-up Adjustments Maintenance Repair Changes

Date: _____

Technical: _____

Client: _____

Description of the intervention

Installation Start-up Adjustments Maintenance Repair Changes

Date: _____

Technical: _____

Client: _____

Description of the intervention

Installation Start-up Adjustments Maintenance Repair Changes

Date: _____

Technical: _____

Client: _____

Description of the intervention

Installation Start-up Adjustments Maintenance Repair Changes

Date: _____

Technical: _____

Client: _____

Annex B

EC Declaration of Conformity

EC Conformity Declaration

Nome del fabbricante / Company name	Sesamo S.r.l.
Indirizzo postale / Postal address:	Strada Gabannone, 8/10
CAP e Città / Postcode and City:	I – 15030 - Terruggia (AL)
Telefono / Telephone :	+39 0142 403223
E-mail address:	info@sesamo.eu
Sito web / Web site	www.sesamo.eu

This Declaration of Conformity² is issued under the sole responsibility of the manufacturer and refers to the following equipment:

This Declaration of Conformity is issued under the sole responsibility of the manufacturer and it belongs to the following equipment:

Dispositivo e modello / Equipment and model	Sliding door - 1 or 2 - wings Powercore PL55 model
Product Type :	PL 55³
Serial number:	To be detected by the identification plate of the car

Subject of the declaration:

Object of the declaration :

Pedestrian doors with operation mod. POWERCORE Type PL 55

Pedestrian doors with driver mod. POWERCORE tipo PL 55



The subject matter of this Declaration of Conformity is in accordance with the applicable Essential Health and Safety Requirements [RESS] which are contained in Annex I of the following European Union legislation /

The subject of this Declaration of Conformity is compliant with the applicable Essential Health and Safety Requirements [EHSR] included in the Annex I of the relevant legislation of European Union :

² This declaration of conformity is valid only if the products to which it refers are installed and used following the use and maintenance instructions delivered by Sesamo Srl as manufacturer of the equipment

³ Door complete with drive, frame and leaf(s) to form the complete sliding pass door

Directive 2006/42/EC (Machinery Directive)

2006/42/EC Directive (Machinery directive)

Reference to the applicable parts of the main relevant harmonized standards /

The applicable requirements of the following harmonized standards and technical specifications have been used:

Titolo / Title :	Data / Date
EN ISO 12100 Safety of machinery – General design principles - Risk assessment and risk reduction	2010
EN 16005 Motorized Pedestrian Doors Safety in use – Requirements and test methods	2012 +A1:2015
EN 60335-1 Household and similar electrical appliances. Safety General requirements	2019
EN 60335-2-103 Household and similar electrical appliances. Safety Particular requirements for drives for gates, doors and windows	2015
EN 61000-6-2 Electromagnetic compatibility (EMC) Part 6-2: Generic standards - Immunity standard for industrial environments	2016
EN 61000-6-3 Electromagnetic compatibility (EMC) Part 6-3: Generic standards - Emission standard for equipment in residential environments	2020
EN 13849-1 Safety of machinery – Safety-related parts of control systems - Part 1: General principles for design	2015
EN 13849-2 Safety of machinery – Safety-related parts of control systems - Part 2: Vacoveration	2012

Other technical specifications used /

Other technical specification applied:

Titolo / Title :	Data / Date
==	==
==	==

Notified body (if applicable) /

Notified body (where applicable):

Not applicable

Not Applicable

Additional information : None

Additional information : None

In response to a reasoned request from the competent national authorities, the manufacturer undertakes to make available all relevant information - on the machinery - without prejudice to his intellectual property rights.



In response to a reasoned request by the national competent authorities, the manufacturer of the machinery agrees to make all the relevant information - on the machinery - available unless of his intellectual property rights

The machinery covered by this declaration also complies with the provisions of the following European directives

The machinery subject of this declaration is also conformed with the provisions of the following european directive

Directive 2014/30/EU (electromagnetic compatibility)

2014/30/EU Directive (Electromagnetic compatibility)

Name and address of the person authorized to prepare the technical file <i>Name and address of the person authorized to compile the technical file,</i>	
	<p style="text-align: center;">SESAMO S.r.l. Strada Gabannone, 8/10 I – 15030 Terruggia (AL)</p>
Signed in the name and on behalf of / <i>Signed for and on behalf of:</i>	Identification and signature of the person authorised to draw up the declaration on behalf of the manufacturer <i>Identity and signature of the person empowered to draw up the declaration on behalf of the manufacturer</i>
	<p style="text-align: center;">Person authorized by the company Sesamo S.r.l. Strada Gabannone, 8/10 I – 15030 Terruggia (AL)</p>

Terruggia (AL) / Italy : **DD/MM/YY**