



ERT80



Derived from the original
instructions
Rel. 00 - 02/26



Management
System
ISO 9001:2015

www.tuv.com
ID 9105038848



Declaration of Compliance

Voluntary Certification



TUV IT 26 MAC 516

Manufacturer	
<i>Name</i>	Sesamo s.r.l.
<i>Address</i>	str. Gabannone, 8/10
<i>ZIP Code</i>	15030
<i>City</i>	Teruggia (AL)
<i>Country</i>	Italy
Object	
<i>Typology</i>	Partly completed machinery
<i>Designation</i>	Power operated pedestrian doorsets
<i>Model/type</i>	Powercore: PL55, PW100, PW140, PW250, PWT80 <input type="checkbox"/> Single sample <input checked="" type="checkbox"/> Group of samples
<i>Serial number</i>	/
<i>Year</i>	2025
Legislative Reference	
2006/42/EC - Annex I and Annex II part 1B	
Applicable Standard	
A Type Standard	
EN ISO 12100:2010	
B Type Standard	
EN ISO 13849-1:2023	
C Type Standard	
EN 60335-2-103:2015	EN 16005:2023+A1:2024
Other Standard	
/	/
Reference to the Technical Report	
PCMTRoC-MAC-722385096	

The product is not referred to Annex IV of the Directive 2006/42/EC

Issue date: 02/02/2026

Expiry date: 01/02/2029

Industrie Service Division Manager



Alberto Carelli
 Signature

First issue date: 02/02/2026

Expiration date of the last certification cycle: -



Declaration of Compliance

DC Ref.:	TUV IT 26 MAC 516	
Manufacturer:	Sesamo s.r.l.	
Object:	Power operated pedestrian doorsets, Powercore PL55, PW100, PW140, PW250, PWT80	
Doc. Ref.:	Directive 2006/42/EC	

Group of samples

The models that are part of the POWERCORE family, subject to this certification, are as follows:
PL55, PW100, PW140, PW250, PWT80.

Main technical data

//

Reliability data

The control circuits with safety function for the models in question reach PL c, according to EN ISO 13849-1:2023.

Validity Conditions

	<p>This technical document is only valid for the referenced company and its facilities stated on the document.</p> <p>The right to use the mark shown on the document only covers the products mentioned in this document.</p> <p>Each product must be accompanied by the necessary operating and assembly instructions. All products must clearly state the name of the manufacturer.</p> <p>In addition to the above conditions, this document of TÜV Italia shall apply the actual condition of the overall contract.</p> <p>The document is valid for all the time in which it can be considered applicable requirements of the state of art according to which the validation has been performed.</p> <p>The product take in exam in this technical document is not covered by Annex IV of 2006/42/EC Directive.</p>
---	---

TABLE OF CONTENTS

0. DECLARATIONS OF INCORPORATION	5
1. INTRODUCTION	7
1.1. INSTRUCTIONS FOR THE INSTALLER (SAFETY OBLIGATIONS) AND RESIDUAL RISKS	7
1.2. WARNINGS FOR THE USER.....	8
1.3. DISASSEMBLY, RECYCLING AND DISPOSAL	9
1.4. SYMBOLS MEANING.....	10
2. ERT80 – INTENDED USE / INSTALLATION CONFIGURATION	11
2.1. LIMITS OF USE.....	11
2.2. PROHIBITED USE	11
2.3. INSTALLATION CONFIGURATION	12
3. IDENTIFICATION PLATE.....	13
4. TECHNICAL FEATURES	14
5. OPERATOR COMPOSITION AND INPUT CONFIGURATION	15
6. OPERATOR INSTALLATION	18
6.1. OPERATOR TRACK	18
6.2. OPERATOR FASTENING.....	19
6.2.1. GETTING STARTED.....	19
6.2.2. TYPE OF SUPPORTS AND FIXINGS	20
6.2.3. AUTOMATIC FIXING DIMENSIONS.....	20
6.2.1. TABLE OF OPERATIONS TO BE PERFORMED FOR ASSEMBLY.....	29
6.2.2. TRACK FIXING.....	30
6.2.3. ASSEMBLY AND ADJUSTMENT OF WINGS/WING – ASSEMBLY AND ADJUSTMENT OF CARRIAGES	35
6.2.4. FASTENING OF THE BELT CLAMPING SUPPORT/SLOW WINGS	35
6.2.5. INSTALLATION OF THE SLIDING GUIDE FOR FAST WING	37
6.2.6. QUICK WING/WING ASSEMBLY AND ADJUSTMENT – CARRIAGE ASSEMBLY AND ADJUSTMENT	40
6.2.7. CARRIAGE INSTALLATION	42
6.2.8. FASTENING OF THE BELT PRESS-BELT SUPPORT FOR THE DOOR/FAST DOOR	48
6.2.9. COMPONENT REPOSITIONING AND BELT TENSIONING.....	49
6.2.10. FINAL ASSEMBLIES	55
7. FINAL CHECKS MECHANICAL ASSEMBLY	56
7.1 CONNECTIONS AND COMMISSIONING	56
8. USER MANUAL	57
9. MAINTENANCE MANUAL	64

0. DECLARATIONS OF INCORPORATION

MACHINERY DIRECTIVE

The installer who drives a door becomes the manufacturer of the automatic door machine in accordance with Directive 2006/42/EC and must:

- Prepare the Technical File with the documents indicated in Annex VII of the Machinery Directive and keep it for at least 10 years.
- Draw up the EC declaration of conformity in accordance with Annex II-A of the Machinery Directive and provide a copy to the user.
- Affix the CE marking to the motorized door in accordance with section 1.7.3 of Annex I of the Machinery Directive.

Declaration of Incorporation of pre-assembled

Machinery Directive 2006/42/EC, Annex II, Part B

Manufacturer: SESAMO S.R.L.

Address: Str. Gabannone 8/10 - 15030 Terruggia – AL – ITALY

Declares that:

The product: redundant drive for pedestrian sliding doors model **POWERCORE** type **ERT80** supplied **assembled** with serial number XXXX¹

- complies with the essential safety requirements set out in Annex I of the Machinery Directive 2006/42/EC with the exception of the following points: 1.2.4.3, 1.3.4, 1.3.7, 1.3.8.2, 1.5.14, 1.5.15, 1.6.3
- complies with the requirements of the following other European Directives: 2014/30/EU Electromagnetic Compatibility

and that

- the following (parts/clauses of) harmonized standards have been applied:

EN 60335-1, EN 60335-2-103, EN 61000-6-2, EN 61000 -6-3, EN 12100, EN 16005, EN 13849-1, EN 13849-2

and further declares that:

- the relevant technical documentation has been compiled in accordance with Part B of Annex VII; Such documentation, or parts thereof, will be transmitted by post or by electronic means, in response to a reasoned request from the competent national authorities
- the person in charge of preparing the relevant technical documentation is: SESAMO SRL, Strada Gabannone, 8/10 - 15030 Terruggia (AL) - Italy
- it is not permitted to put the product into service until the machinery in which it will be incorporated or of which it will become a component has been identified and its conformity with the conditions of Directive 2006/42/EC and the national legislation transposing it, i.e. until the machinery referred to in this declaration forms a single unit with the machinery.

SESAMO S.R.L.
July 2025

Daniele Amerio
(Administrator)

¹ Refer to the serial number found on the nameplate of the pre-assembled operator

Declaration of Incorporation of the KIT

Machinery Directive 2006/42/EC, Annex II, Part B

Manufacturer: SESAMO S.R.L.

Address: Str. Gabannone 8/10 - 15030 Terruggia – AL – ITALY

Declares that:

The product: redundant drive for pedestrian sliding doors model **POWERCORE** type **ERT80** supplied in kit

- complies with the essential safety requirements set out in Annex I of the Machinery Directive 2006/42/EC with the exception of the following points: 1.2.4.3, 1.3.1, 1.3.2, 1.3.4, 1.3.7, 1.3.8.1, 1.3.8.2, 1.4.1, 1.4.2.1, 1.5.14, 1.5.15, 1.6.3
- complies with the requirements of the following other European Directives: 2014/30/EU Electromagnetic Compatibility

and that

- the following (parts/clauses of) harmonised standards have been applied:

EN 60335-1, EN 60335-2-103, EN 61000-6-2, EN 61000 -6-3, EN 12100, EN 16005, EN 13849-1, EN 13849-2

and further declares that:

- the relevant technical documentation has been compiled in accordance with Part B of Annex VII; Such documentation, or parts thereof, will be transmitted by post or by electronic means, in response to a reasoned request from the competent national authorities
- the person in charge of preparing the relevant technical documentation is: SESAMO SRL, Strada Gabannone, 8/10 - 15030 Terruggia (AL) - Italy
- it is not permitted to put the product into service until the machinery in which it will be incorporated or of which it will become a component has been identified and its conformity with the conditions of Directive 2006/42/EC and the national legislation transposing it, i.e. until the machinery referred to in this declaration forms a single unit with the machinery.



SESAMO S.R.L.
July 2025

Daniele Amerio
(Administrator)

1. INTRODUCTION

Thank you for your preference for this product. In order to obtain the best performance from the operator, Sesamo recommends that you carefully read and follow the installation and use instructions in this manual. The installation of this operator must be carried out only by professionally competent people to whom this manual is addressed. Packaging materials (wood, plastic, cardboard, etc.) must not be dispersed in the environment or left within the reach of children as a potential source of danger. Before starting the installation, make sure that the product is intact and has not suffered damage resulting from transport or poor storage.

Before carrying out any operation, it is necessary to read this manual carefully and follow all its instructions, with particular attention to those marked by the following references:

	DANGER	Indications that, if not scrupulously followed, could generate sources of danger or death
	CAUTION	indications that, if not followed scrupulously, could generate malfunctions

1.1. INSTRUCTIONS FOR THE INSTALLER (SAFETY OBLIGATIONS) AND RESIDUAL RISKS



1A) The operator is supplied with a single package, which can be handled by hand. For handling, refer to the weight indicated on the packaging, considering that for each person the maximum weight that can be handled must not exceed 20 kg.

1B) The doors are supplied packaged on pallets whose weight is indicated on the packaging. The handling of the entire pallet must be carried out with a pallet truck, or by opening the packaging and carrying out the manual handling of the individual pieces as described in point 1 above. In this operation, the use of suitable personal protective equipment is required, at least safety shoes and gloves.

1) It is important for the safety of people to install the operator in accordance with the instructions. Incorrect installation or incorrect use of the product can cause serious injury to people. Installation must be done only by qualified and experienced personnel and in full compliance with current regulations.

2) Read the instructions carefully before starting the installation of the product.

3) Keep the instructions for future reference.

4) This product has been designed and constructed solely for the use indicated in this documentation. Any other use not expressly indicated could compromise the integrity of the product and/or represent a source of danger. Every single phase of the installation must be carried out in accordance with the regulations in force and in any track according to the dictates of Good Technique.

5) SESAMO declines any responsibility derived from improper use or use other than that for which the operator is intended and indicated in this documentation.

6) Do not install the appliance in an explosive atmosphere: the presence of flammable gases or fumes constitutes a serious safety hazard.

7) SESAMO is not responsible for non-compliance with Good Technique in the construction of the closures to be motorized, as well as for deformations that may occur during use.

8) Before installing the product, make sure that each architectural and structural element of the entrance (automatic fixing surface, fixtures, etc.) is suitable and robust enough to be automated.

9) Before carrying out any work on the system, disconnect the power supply. Check that there is a residual current circuit breaker with a threshold not exceeding 0.03 A and adequate overcurrent protection upstream of the system. Check that the earthing system is made in a workmanlike manner. Also ensure that it is not possible to restore the electrical supply inadvertently or unintentionally (e.g. padlock switch or plug/socket combination in sight of the technician who is operating the machine).

10) Also disconnect any backup batteries if present.

11) Before connecting the power supply, make sure that the data on the rating plate corresponds to those of the electrical distribution network.

12) Before installing the product, carry out a careful risk analysis and make all structural changes relating to the construction of safety clearances and the protection or segregation of all crushing, shearing, conveying and danger areas in general, in accordance with the provisions of the EN 16005 standard or any local installation regulations. Verify that the existing structure has the necessary requirements for strength and stability

- 13) Fit safety devices of the type in accordance with EN 12978 that allow any danger areas to be protected from mechanical risks of movement in relation to the risk analysis carried out, such as crushing, conveying, shearing. Sesamo declines all responsibility for the safety and proper functioning of the operator if components from other manufacturers are used.
- 14) For maintenance, use only original SESAMO parts. Ask SESAMO for spare parts by indicating the serial number shown on the identification plate.
- 15) Do not make any changes to the components that are part of the operator system.
- 16) The installer must provide all information regarding the manual operation of the system in the event of an emergency.
- 17) The doors to be automated must have a uniform and friction-free opening and closing movement
- 18) Anything not expressly provided for in these instructions is not permitted.
- 19) This manual is intended for professional installers or competent persons only.
- 20) At the end of the installation, give the user this manual, and in particular the WARNINGS FOR THE USER section and any further information for the correct use of the system.
- 21) Upon completion of the installation, apply a door identification plate
- 22) At the end of the installation, assess the possible presence of hazards whose elimination/mitigation is not possible, for example risk of slipping, tripping, falling due to slippery surfaces due to rain, snow, ice and report their presence to the user as residual risks.
- 23) This manual is a translation of the original Italian version; in case of any ambiguity, refer to the original instructions in Italian.

1.2. WARNINGS FOR THE USER

 **WARNING** Read and follow the Warnings and Instructions accompanying the product carefully, as improper use may result in damage to people, animals or property. Keep the instructions for future reference and pass them on to any successors in the use of the system.

This manual is a translation of the original Italian version; in case of any ambiguity, refer to the original instructions in Italian.

This product is intended only for the use for which it was expressly designed. Any other use is to be considered improper and therefore potentially dangerous. The manufacturer cannot be held responsible for any damage caused by improper, erroneous and unreasonable use.

 **GENERAL SAFETY**

Thank you for your preference for this product. In order to obtain the best performance from the operator, Sesamo recommends that you carefully read and follow the instructions for use in this manual

This product complies with recognized technical standards and safety regulations when correctly installed by qualified and experienced personnel (professional installers).

The operator, if installed and used correctly, meets the safety standards in use. However, it is advisable to observe some rules of conduct to avoid accidental inconveniences:

- Keep children out of the range of the operator, particularly during movement.
- Do not allow children to play or stand within range of the operator. Children must not play with the appliance.
- Do not run through the door while the door is closing
- Cleaning and maintenance intended to be carried out by the user must not be carried out by children without supervision.
- Avoid working near hinges or moving mechanical parts.
- Do not oppose the movement of the leaf and do not attempt to open the door manually if the actuator has not been unlocked with the appropriate release.
- The breakage or wear of mechanical parts of the door (guided part), such as cables, springs, supports, hinges, guides... could generate dangers. Have the system checked periodically by qualified and experienced personnel (professional installer) as indicated by the installer or door manufacturer.
- Keep the sensor optics clean. Check that objects such as curtains, branches or other objects do not disturb the safety devices.
- Do not use the operator if it needs repair. In the event of a breakdown or malfunction of the operator, disconnect the mains power supply to the operator, refrain from any attempt at repair or direct intervention, and refer to only qualified and experienced personnel (professional installers) for the necessary repair or maintenance. To allow exit, turn on the emergency release (if equipped).
- Have the integrity and correct operation of the operator checked by qualified and experienced personnel (professional installers), particularly all safety devices, with the frequency set out in the user manual.

- Installation, maintenance and repair work must be documented, and the relevant documentation must be kept available to the user.
- Failure to comply with the above may create dangerous situations.

1.3. DISASSEMBLY, RECYCLING AND DISPOSAL

WARNING! This product falls within the track of Directive 2012/19/EU concerning the management of waste electrical and electronic equipment (WEEE). The appliance should not be disposed of with household waste as it is made from a variety of materials that can be recycled at the appropriate facilities. Inquire through the municipal authority regarding the location of the ecological platforms suitable for receiving the product for disposal and its subsequent correct recycling. It should also be noted that in the event of the purchase of an equivalent appliance, the distributor is required to collect the product to be disposed of free of charge. The product is not potentially dangerous for human health and the environment, as it does not contain harmful substances as per Directive 2011/65/EU (RoHS), but if abandoned in the environment it has a negative impact on the ecosystem.



Dismantling operations must be managed by qualified and experienced personnel and in full compliance with current regulations. These operations must include:







- Disconnect the mains power supply and batteries if present.
- Disconnect all electrical cables connecting to external devices
- disassembly of sliding and fixed wings using due care to prevent the fall of the wings themselves or components such as sliding carriages.
- Dismantling the operator















The symbol of the crossed-out wheeled bin indicates that this product complies with the regulations relating to waste electrical and electronic equipment. Leaving the equipment in the environment or illegally disposing of it is punishable by law.

1.4. SYMBOLS MEANING

	DANGER	It indicates that, if not scrupulously followed, could generate sources of danger or death
	CAUTION	It indicates that, if not followed scrupulously, could generate malfunctions
	WARNING RISK OF ELECTROCUTION	It indicates a risk of electrocution. The operation must be carried out in compliance with safety regulations

	Obligation in track of protection.
	Safety shoes are mandatory.
	Mandatory mask/goggles suitable for eye protection.
	Work gloves are mandatory.
	Ear protections are mandatory.
	Mandatory overalls.

	Hex Wrench + Size		Circular saw
	Allen key + size		Metal drill bit
	Socket wrench		Masonry drill bit
	Flat screwdriver		Thread Tap M...
	Phillips screwdriver		Bubble / Level
	Torque Adjustable Tool  Nm		Wire stripping pliers

2. ERT80 – INTENDED USE / INSTALLATION CONFIGURATION

The ERT80 operator must be used exclusively for the movement of sliding pedestrian doors. In particular, this version is designed for doors installed on escape routes in compliance with the requirements of the EN 16005 standard - paragraph 4.7.2. ERT80 adopts some components in redundant form and is equipped with a double in-line gearmotor and two electronic control units, one for control and one for safety. The two control panels allow cross-monitoring and continuous monitoring of operation and a special algorithm assigns control to one control panel in the event of failure of the other. The double in-line motor movement ensures a continuous self-test of operation and guarantees safe opening and positioning in the event of failure of one of the two motor bodies. The ERT80 control panel is equipped with a special input to operate in combination with sensors compliant with EN 13849-1:2015 performance level "d" Cat.2 specially designed to ensure the safe opening of doors installed on escape routes

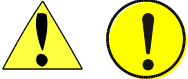

Any other use, other than that stated in the chapter, is NOT PERMITTED by the installer. Sesamo declines any responsibility derived from improper use or use different from that for which the operator is intended.

2.1. LIMITS OF USE

The ERT80 operator must not be used under the following conditions:

- Direct exposure to the elements
- Direct exposure to water jets of any size or flow rate
- Outside the prescribed technical limits
- Connections to energy sources other than those prescribed – FORBIDDEN

2.2. PROHIBITED USE

It is forbidden:

- Use operator DIFFERENTLY FROM ITS INTENDED USE.
- Use operator to make entrances for fire and smoke protection.
- Use the operator in places where there is a risk of fire/explosion (presence of gases, flammables, etc. the product is not certified with the ATEX directive).
- Integrate unforeseen commercial parts
- Integrate commercial parts for uses not permitted by their respective manufacturers.
- Use commercial devices for use other than as intended by their manufacturers.

2.3. INSTALLATION CONFIGURATION

The operator is designed to work with different configurations of accessories and peripherals. The image shows an example of a complete installation where the possible access points in the box of the operator for the connection of the following peripherals are highlighted.

Fig.1

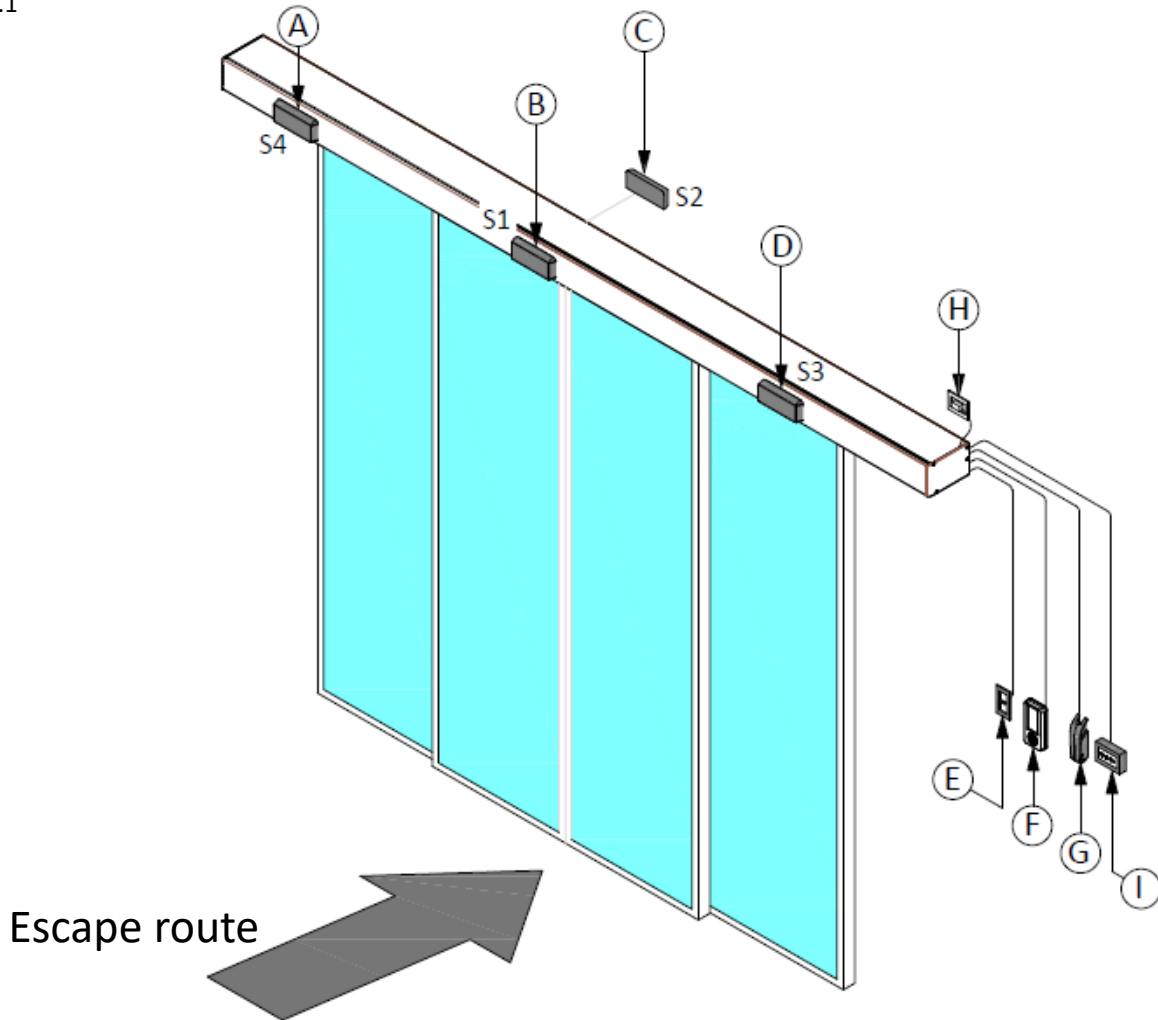

A	Safety sensor on the left side opening.	E	Residual current circuit breaker (230Vac mains power supply). NOT PROVIDED
B	Internal closing safety sensor and opening – exclusive for ERT80 -Sensor compliant with EN 13849-1:2015 performance level "d" Cat.2 for escape routes.	F	Digidor RD operating logic selector.
C	External sensor for opening and safety in closing.	G	Manual lever for manual electric-lock release (Optional).
D	Safety sensor on the right side	H	230Vac power supply.
		I	Emergency open push button.

Prepare the access points inside the operator to allow them to be connected with external peripherals. To pass the mains power cable, use the notch provided on the head or make one affixed to the aluminium track profile. Protect the cable with the cable rubber supplied.

WARNING: Do not damage the cable during the fastening tasks described.



3. IDENTIFICATION PLATE

SESAMO s.r.l.
 Strada Gabannone 8/10 15030 TERRUGGIA (ITALY)
 Tel +39 0142 403223 Fax +39 0142 403256
 www.sesamo.eu E-MAIL info@sesamo.eu

PEDESTRIAN SLIDING DRIVE

Series POWERCORE Type ERT80

Serial Nr AC1H42-FC40653

Year of manufacturing 2025
 Power supply 230 V ~ 50 / 60 Hz 200 W

AG2H42-FC406530

- Automatism (Type): AG = ERT80
- Model
- No. of doors: 2 = 2 doors, 4 = 4 doors
- Month of production: A = January, B = February, C = March,
- Year of production: 42 = 2025, 43 = 2026, 44 = 2027,
- Code generated by the system that makes the cross beam UNIQUE.

The label will be applied as shown in the image to the right or left ends depending on the arrangement of the components:

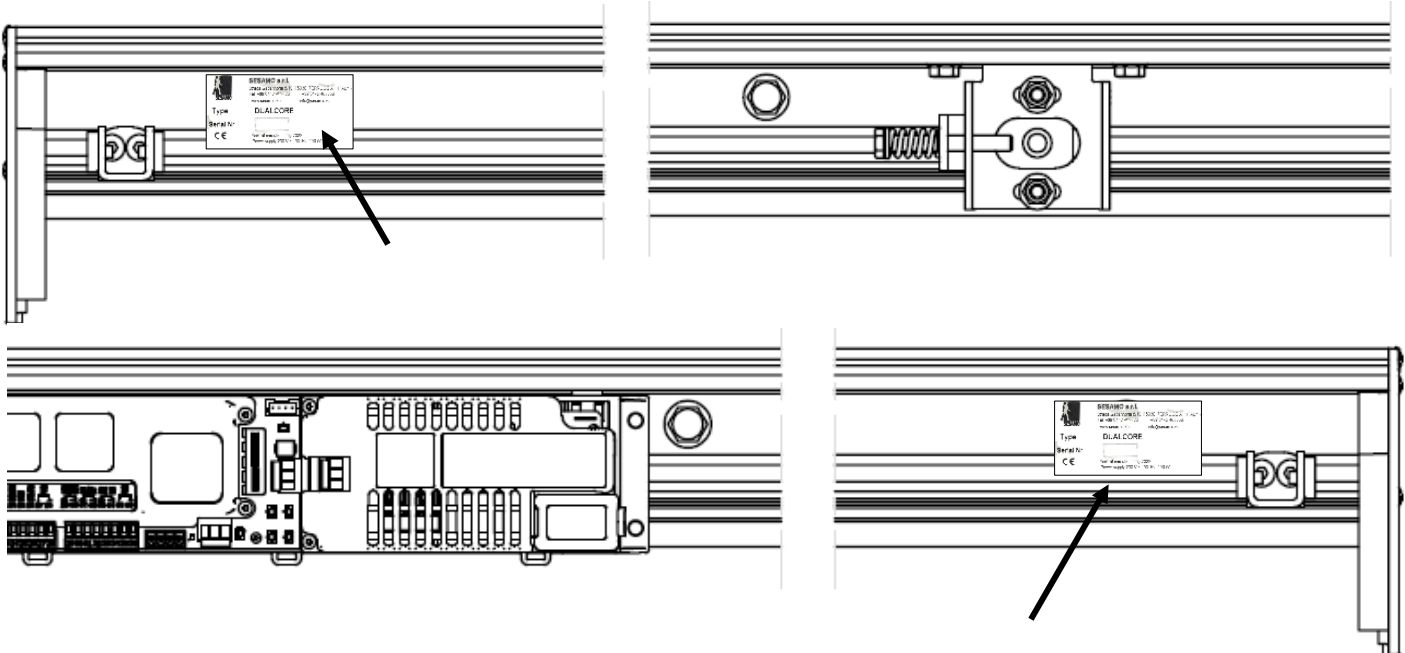

4. TECHNICAL FEATURES

<p>Dimensions</p>	
<p>Allowed dimensions mm</p>	<p>ERT80 2 wings = passage compartment 800 minimum ÷ 3000 maximum – maximum height 3000 ERT80 4 wings = passage compartment 2000 minimum ÷ 3000 maximum – maximum height 3000</p>
<p>Operator weight</p>	<p>14.5 kg/m approx.</p>
<p>Flow rate</p>	<p>2 x ERT80 wings = 100 kg 2 ERT80 wings = 80+80 kg</p>
<p>Power supply</p>	<p>230V ±10% AC 50/60Hz</p>
<p>Rated power</p>	<p>200 W</p>
<p>Service</p>	<p>Continuous</p>
<p>Main motor</p>	<p>Powered by 40Vdc</p>
<p>External devices</p>	<p>Powered 12Vdc - 12W MAX</p>
<p>Auxiliary power system</p>	<p>Battery – 24Vdc</p>
<p>Traction</p>	<p>By transmission belt</p>
<p>Opening speed</p>	<p>2 Doors = 70cm/s 4 Doors = 140 cm/s</p>
<p>Anti-crush</p>	<p>Automatic force limitation in the presence of obstacles</p>
<p>Operating Temperature</p>	<p>-10°C +55°C</p>
<p>Protection</p>	<p>IP20</p>
<p>Emitted noise</p>	<p>< 70 dB (A)</p>

5. OPERATOR COMPOSITION AND INPUT CONFIGURATION

A	Extruded aluminum track profile
B	Sliding track Fast Wing
C	Extruded aluminum slidingrail
D	Anti-vibration rubber for slidingrail
E	Extruded aluminum cover
F	Gasket for extruded cover
G	Brush (Optional, available in 3 sizes)
H	Extruded aluminium gap closer profile (Optional)
I	POWERCORE ER Control Module
L	Gearmotor with encoder - type 63x55 (Main) - type 63x25 (Secondary) - SG80 gearbox
M	Double pulley device for support and tensioning of the fast leaf belt
N	Single device for support pulley and slow wing belt tensioning
O	Safety bistable electric lock (Optional)
P	Door limit switch
Q	Adjustable carriages complete with wheels and anti-derailment wheel
R	Belt clamp with toothed traction belt - fast leaf
S	Fast wing belt press
T	Belt clamp with toothed traction belt - slow leaf
U	Slow wing belt press
V	Electric lock Striker (Optional)
Z	Drive belt
W	Digidor RD programmer selector (with transponder functionality)
K	Emergency Open Release Button

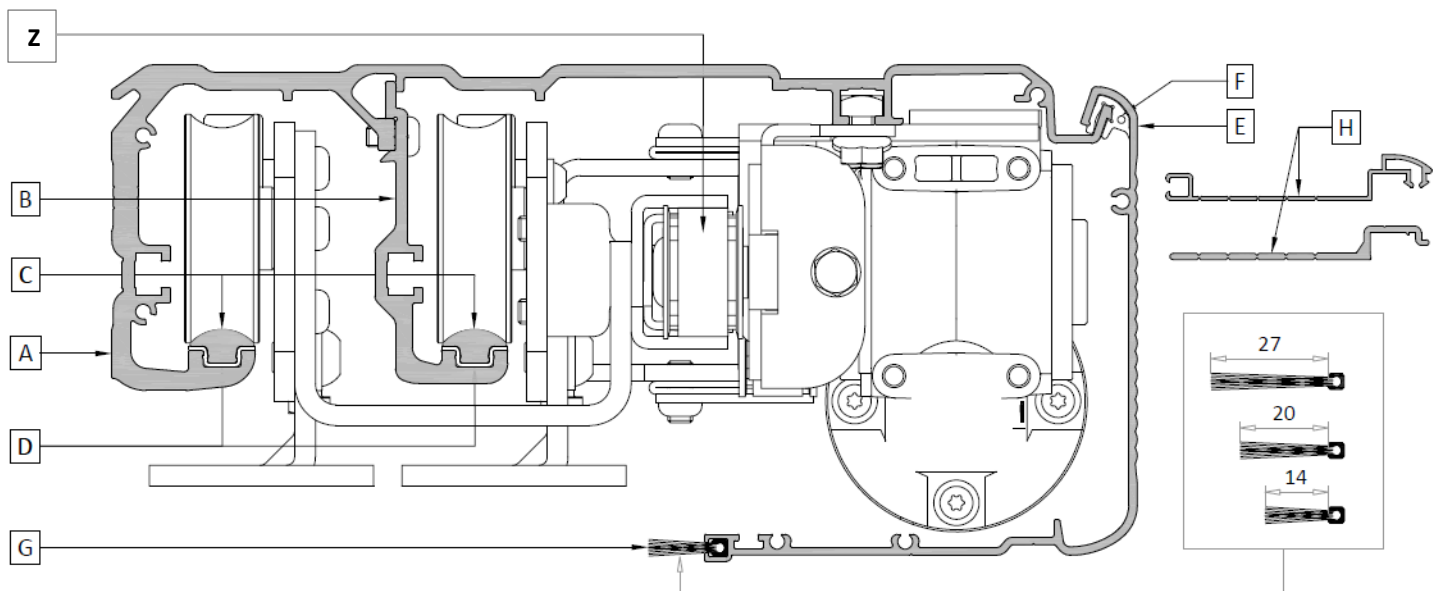

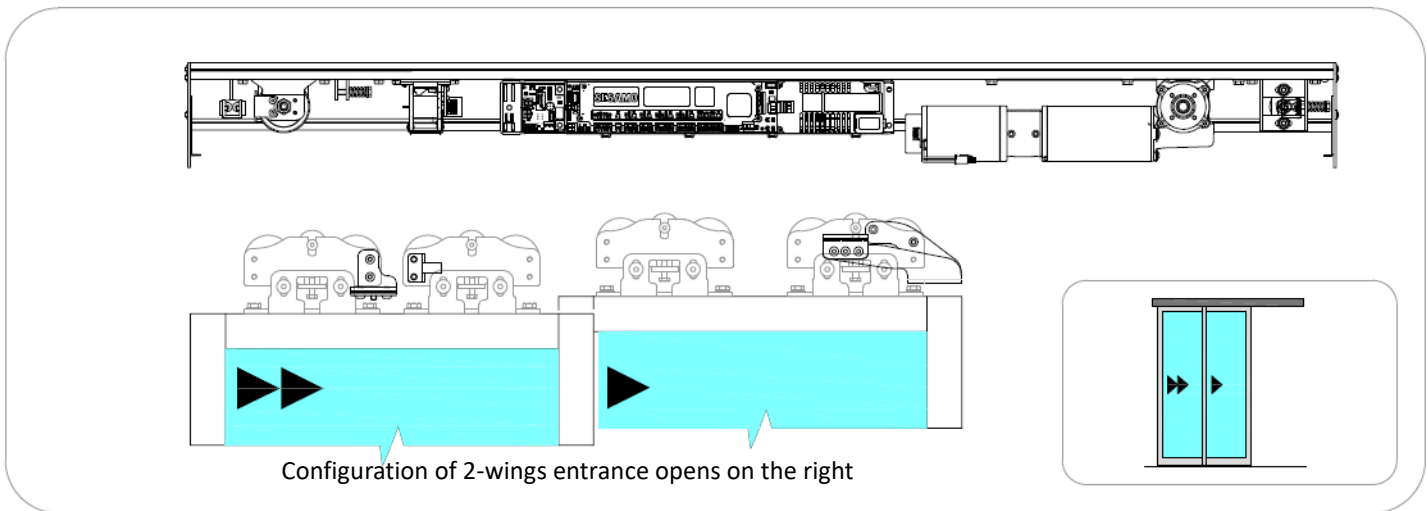
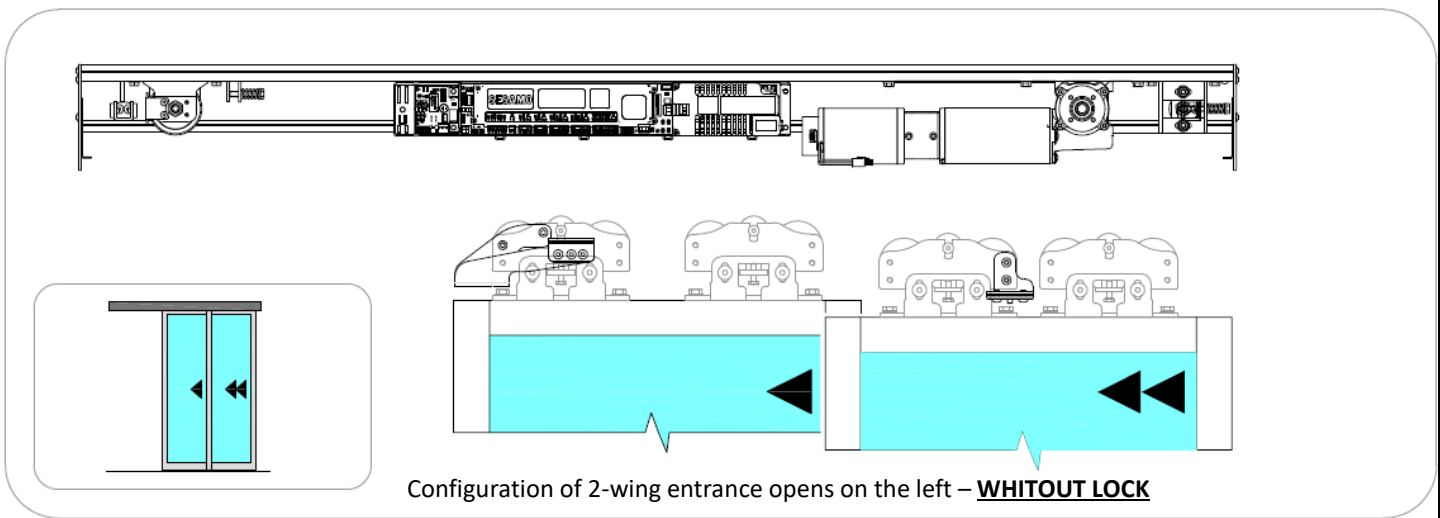
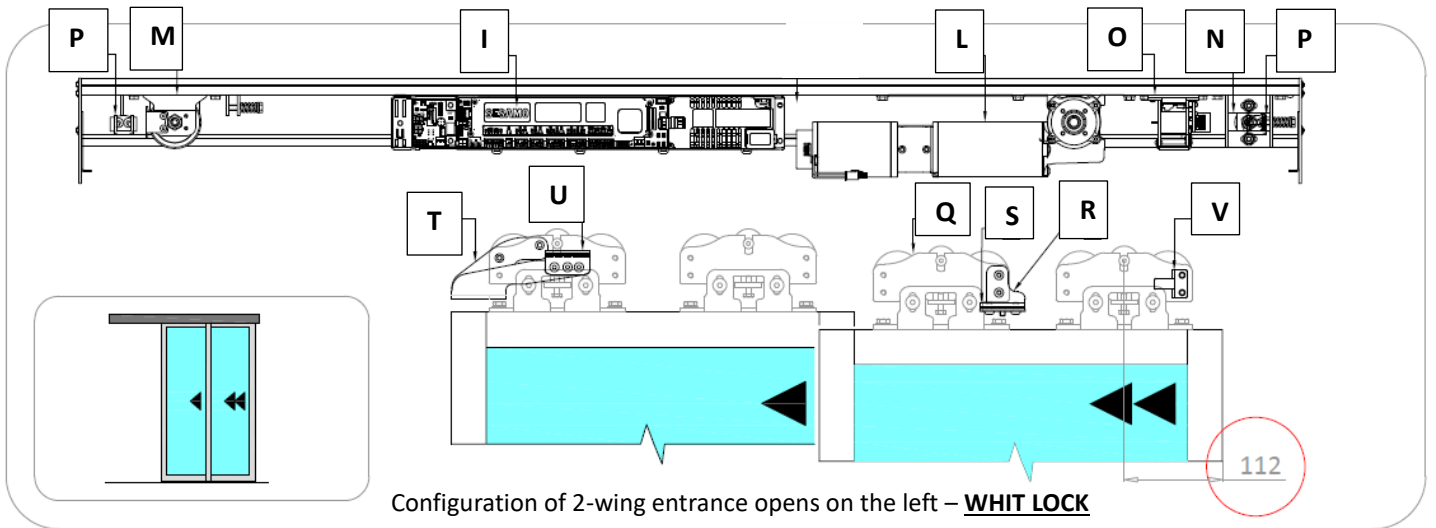

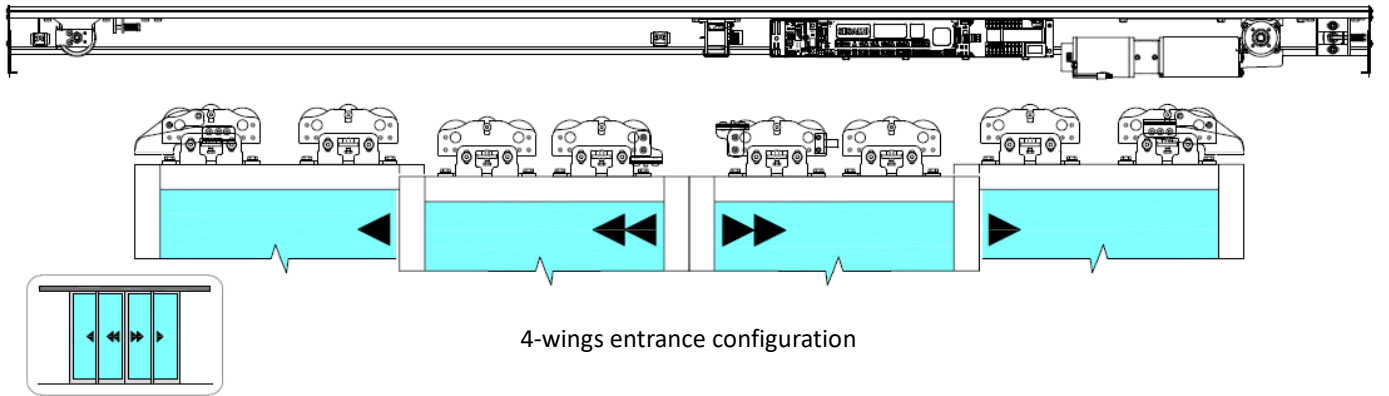

W



K







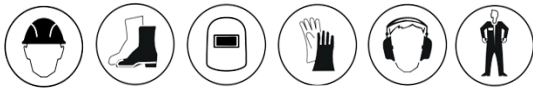



6. OPERATOR INSTALLATION

Individual devices for all operating phases:



List of equipment needed:

	Measurements: 8-10-13
	Measurements: 8-10-13
	Size: 0.8
	Type: Ph n.2

	Sizes: 3-5
	Measurements: Ø6
	Sizes: Ø6.5 - Ø10
	-

6.1. OPERATOR TRACK

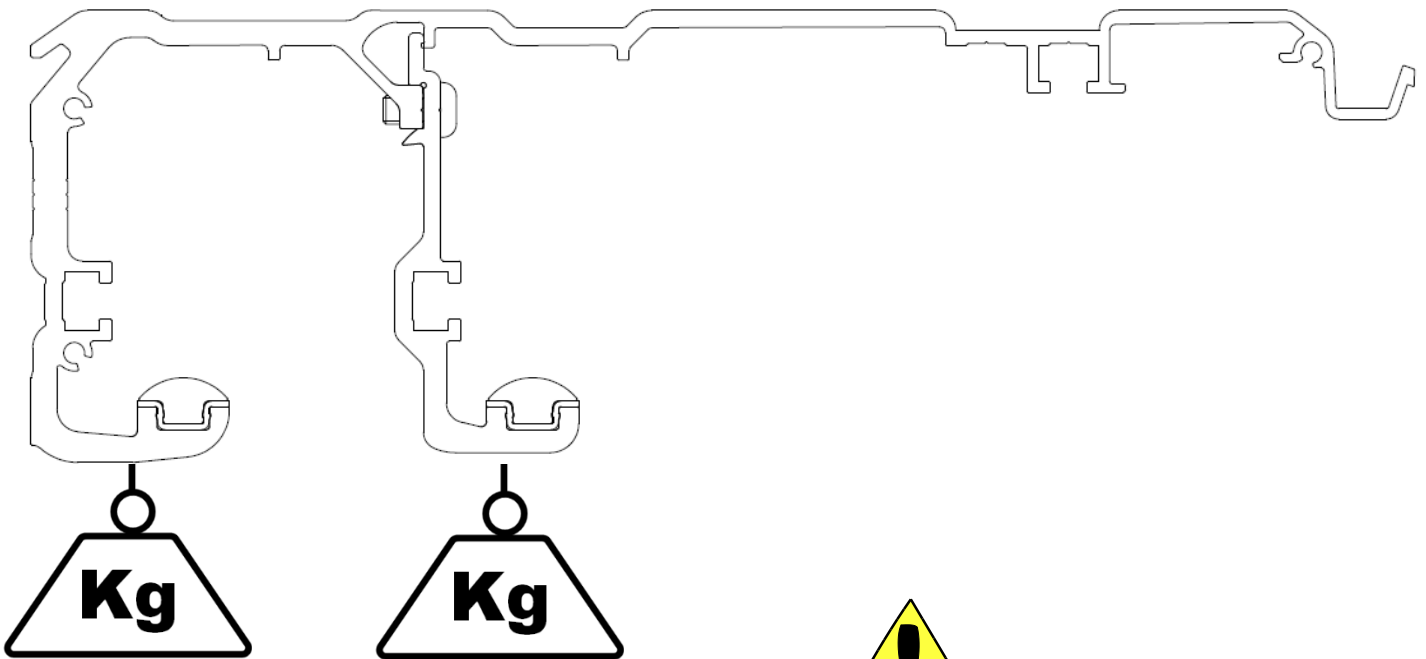

CAPACITY		
Operator	2 wings	4 wings
ERT80	100 Kg	80 Kg + 80 Kg

6.2. OPERATOR FASTENING

6.2.1. GETTING STARTED



The installation and fixing phases of the operator require the handling of heavy parts and tools at a height of more than 2 or 3 meters. Accidental falling of heavy parts and tools is a serious source of risk to people or property in the vicinity. To reduce this risk, before any installation or maintenance work, it is necessary to fence off a sufficiently large area around the work area and prevent access to all people not involved in the work, as well as remove any objects that could be damaged. To reduce the risk to workers, it is necessary to wear personal protective equipment and in particular a head helmet, safety shoes and cut-resistant gloves.

Remove the fixing screws and open the cover as shown in the pictures:



Type: Ph n.2 - Half-round head screw with cross notch + 4.2x16 self-tapping

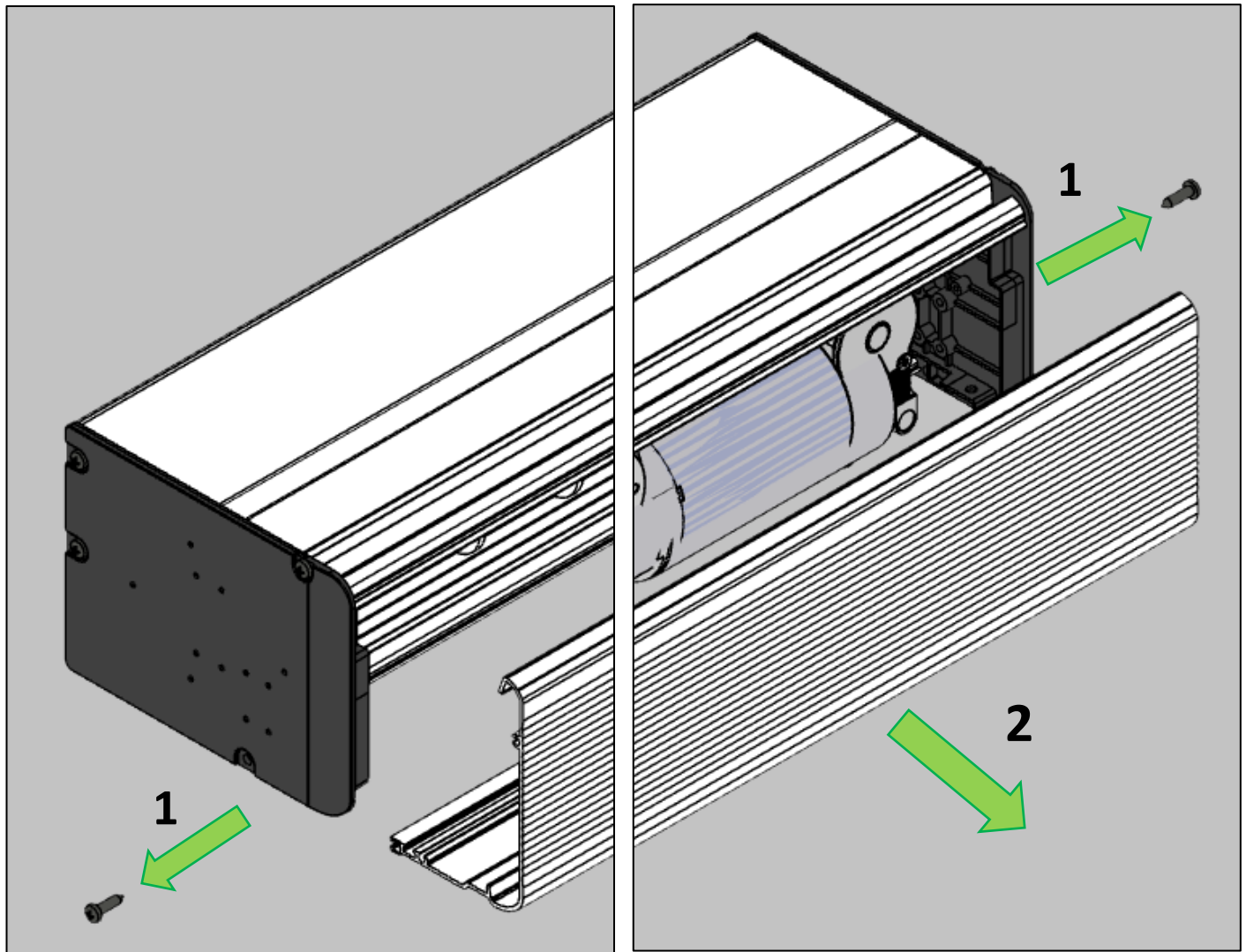

To facilitate the wall fixing of the track, it is possible to move (A) or remove the internal components simply by acting on the screws that fix it (B).

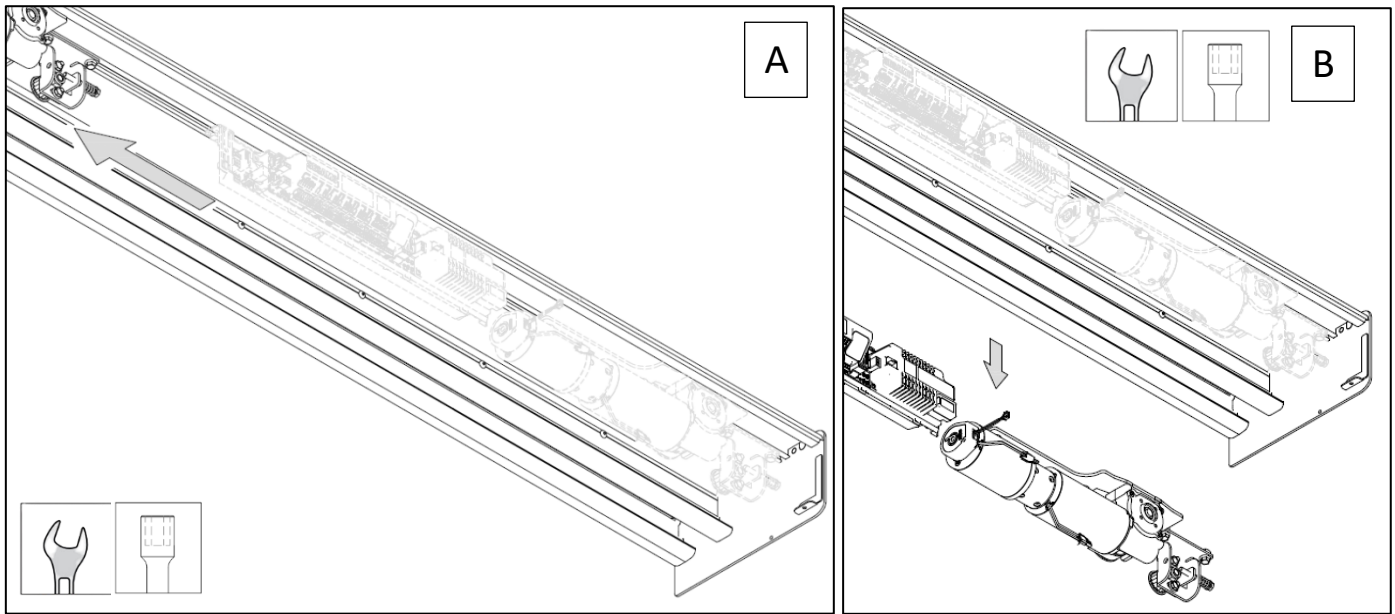

Before moving or removing internal components, take note of their positions or draw reference marks on the track so that they can be correctly positioned.

6.2.2. TYPE OF SUPPORTS AND FIXINGS

Wall mounting support:

Inspect the plane on which the operator will be fixed. If the surface is not smooth enough, level it by interposing shims. If the operator is fixed on a plane that is too uneven, it can be deformed. Make sure that the masonry to which the box and subsequently the sliding doors will be fixed is sufficiently strong and is anchored to the building in an adequate way.

Support for fixing to aluminium structures:

It is possible to use one of the fixing structures made with Sesamo Twenty, S30 or Magnum series profiles with the indications given in the appropriate manual. Do not use any other type of fastener.

Type of fixings:

Fix the box using all the slots and holes made on the casing profile with screws of the following type. If there are no holes or slots on the profile, drill every 300mm.

Fixing on aluminium self-tapping screw Hexagonal head with flange C15 DIN 6928 UNI 6950 measures 6.3 x 22. Wall fixing: M8 dowels of suitable type in relation to masonry.

6.2.3. AUTOMATIC FIXING DIMENSIONS

6.2.3.1 OPERATOR FIXING POINTS



Carefully check the weight of the leaves so that they fall within the maximum capacities allowed by the operator; in track of doubt, do not proceed further in the installation phases; if leaves are installed with a weight at the limit of the system's capacity, shorter maintenance intervals and periodic checks must be provided to assess the state of wear and tear of the parts of the system; Always replace parts that show signs of wear, even slight.



Incorrect fastening could affect the correct functioning of the operator and constitute a source of danger.

6.2.3.2 HORIZONTAL POSITION

N.2 wings open left

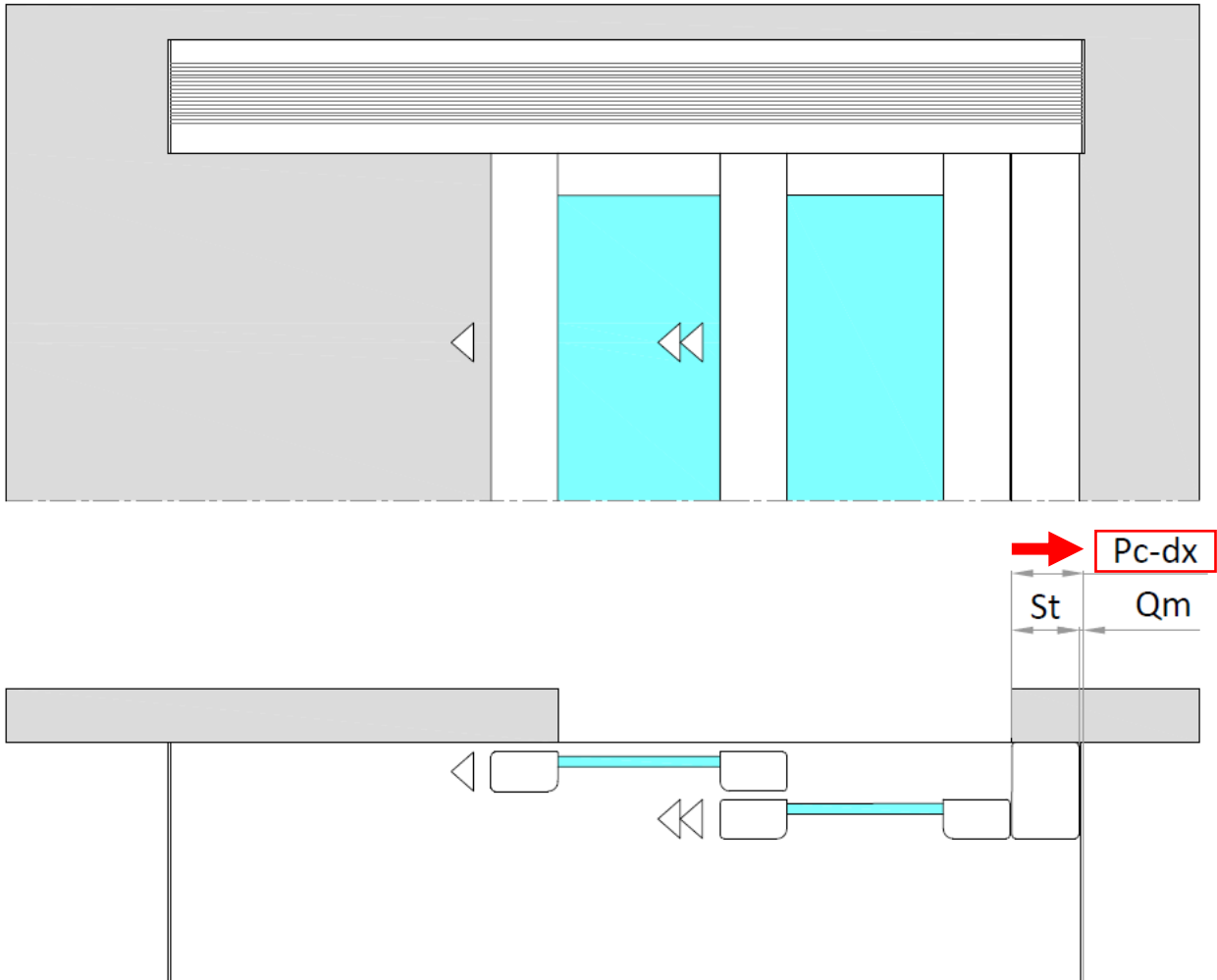

LEGEND	DESCRIPTION	FORMULA
Pc_Dx	Right Track Position	$St + Qm$
Qm	Machine Quotient	Input dependent Min. 5mm
St	Overlapping	Dependent on the profile section



Warning!!!!

In the event of an electrical interlock, the QM (Machine Quotient) may vary.

The minimum value to be considered is 50 mm.

N.2 wings open right

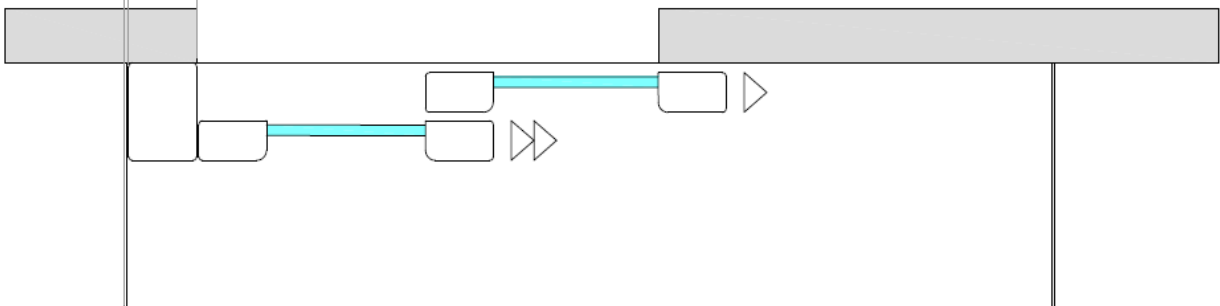
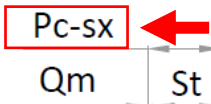
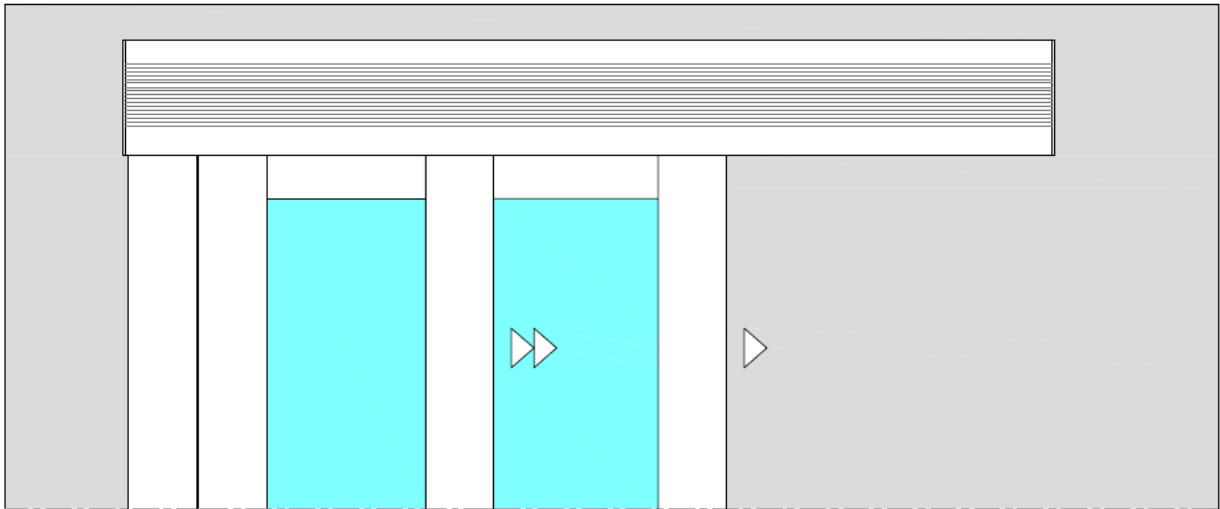

LEGEND	DESCRIPTION	FORMULA
Pc_Sx	Left Track Position	$St + Qm$
Qm	Machine Quotient	Input dependent Min. 5mm
St	Overlapping	Dependent on the profile section

N.4 wings

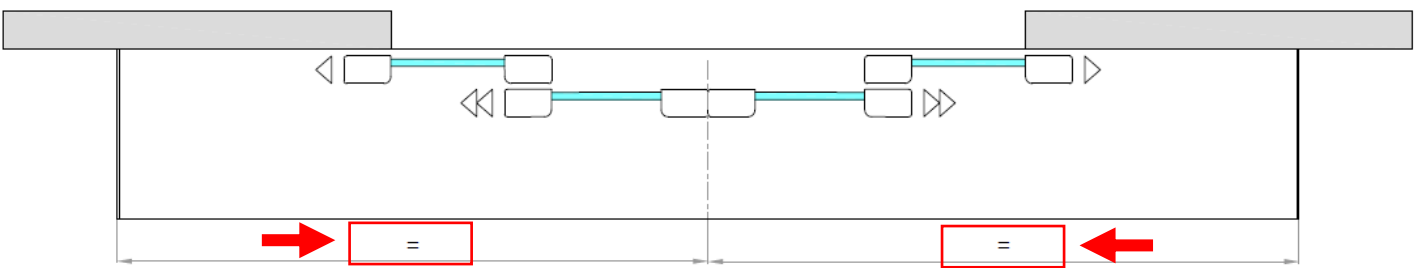
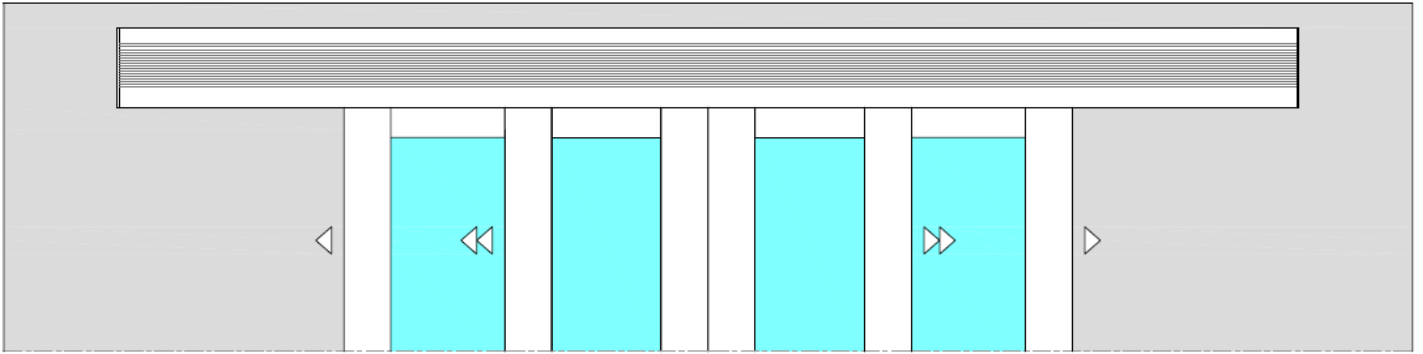

LEGEND	DESCRIPTION	FORMULA
=	Checkout position	Centered in passage
Qm	Machine Quotient	Input dependent Min. 5mm

6.2.3.3 VERTICAL POSITION

The vertical position varies from the type of window installed and the type of assembly, below is the table with all the formulas track by track. From the table it will be possible to obtain the height of the sliding door.



In order to remove the cover for inspection, the operator must have a space of at least 10mm from above the casing.

LEGEND	DESCRIPTION
H	Wall opening height
HUP	Useful passage height
HCA	Track position height
HF	Fixing track hole height

SAWING	FIG.	H	HUP	HCA	HF
Commercial	1	By relief	H=HUP	HUP+46	HCA+46,5
Twenty on the wall	2	By relief	H=HUP	HUP+46	HCA+46,5
Twenty on the wall with fixed door	3	By relief	H=HUP	HUP+46	HCA+46,5
Twenty with beam and fixed door	4	By relief	H-140	HUP+46	HCA+46,5
S30 with fixed wing	5	By relief	H-40	H+17	HCA+46,5
S30 sliding only	6	By relief	H-40	H+17	HCA+46,5
Magnum sliding only	7	By relief	H-26	HUP+19	HCA+46,5
Magnum with beam and fixed door	8	By relief	H-26	HUP+19	HCA+46,5

Fig.1 – Commercial profiles

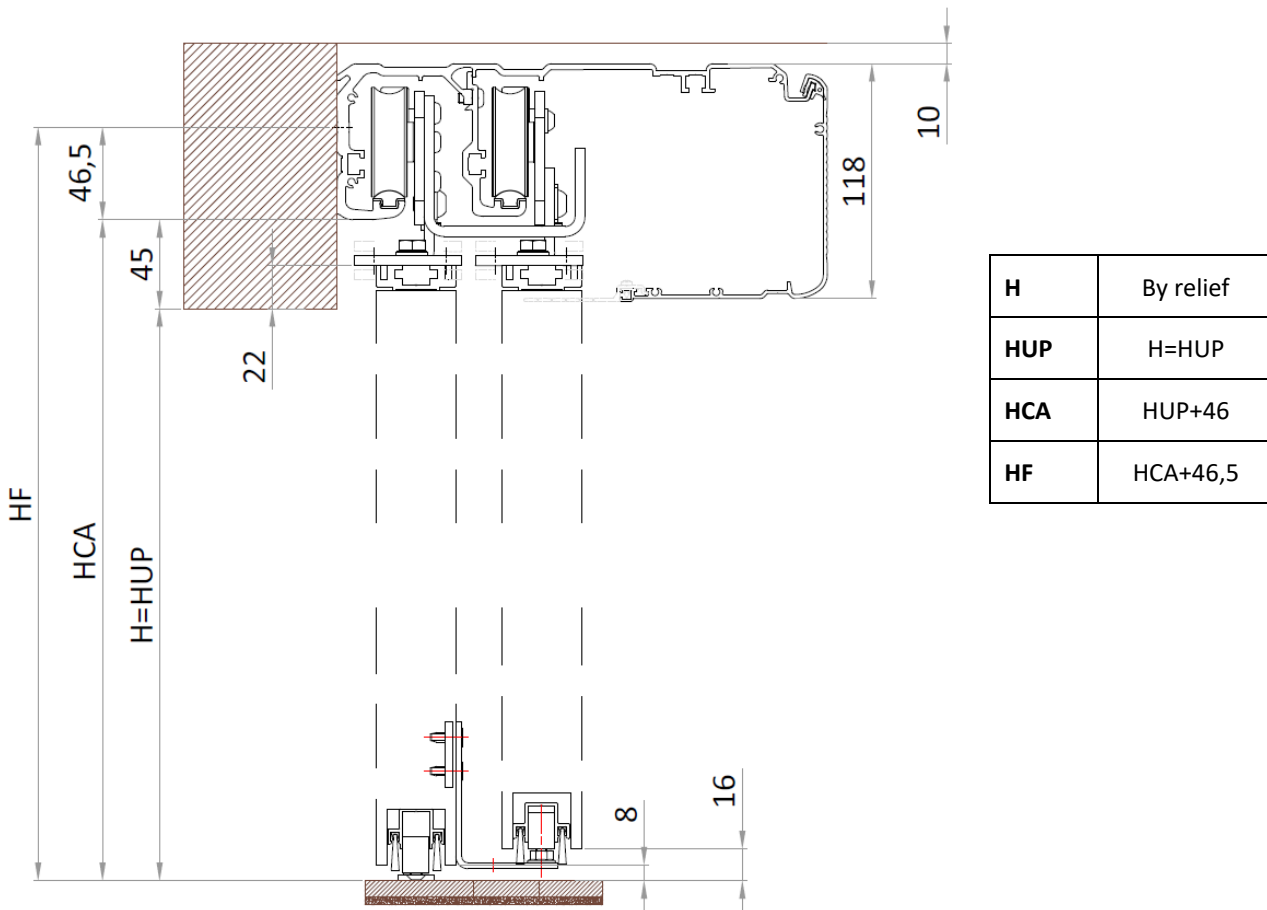
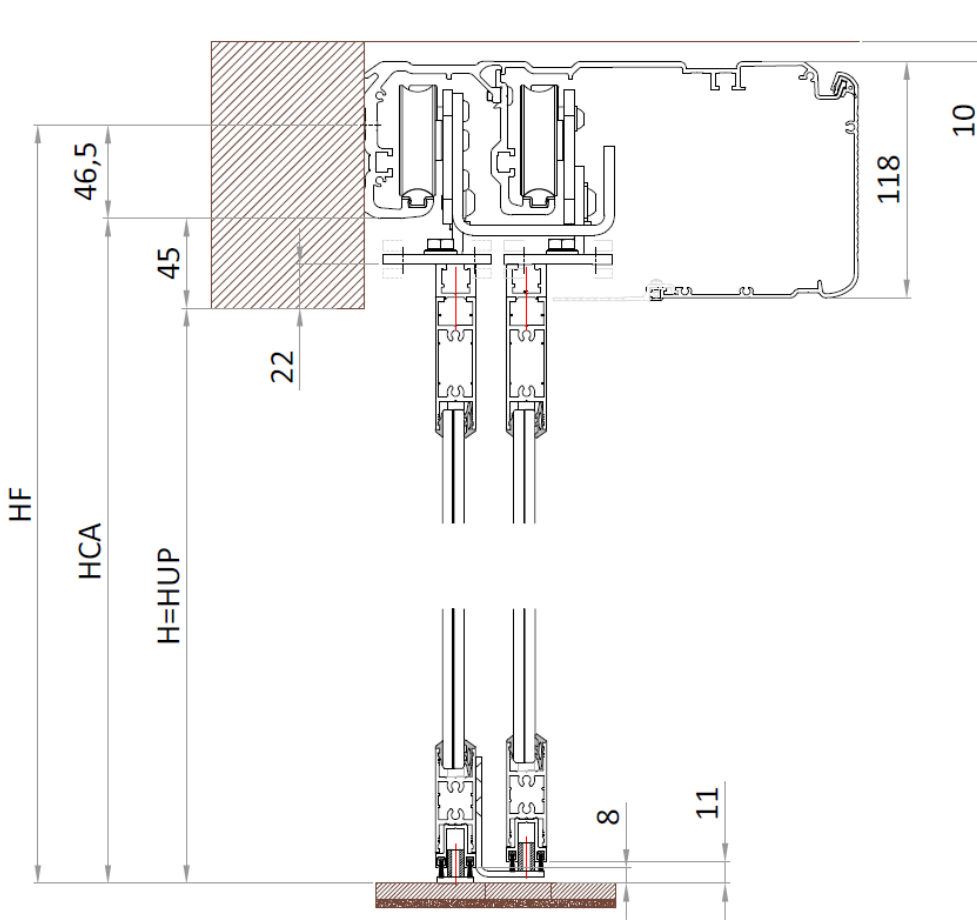
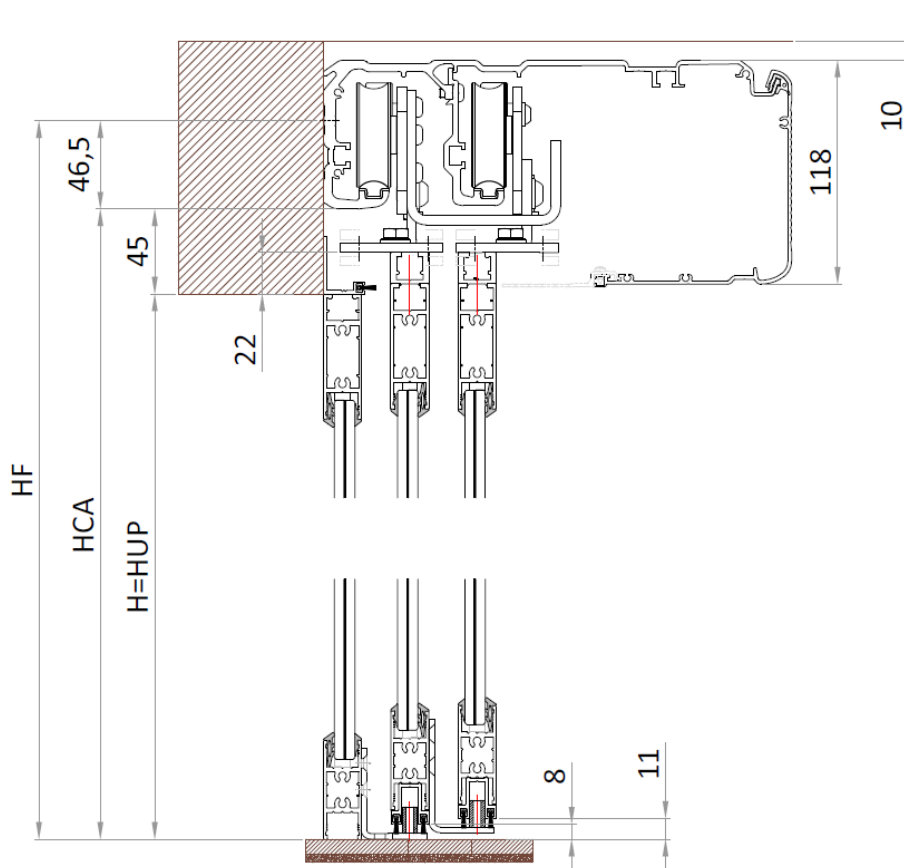

Fig.2 -Twenty on the wall



H	By relief
HUP	H=HUP
HCA	HUP+46
HF	HCA+46,5

Fig.3 – Twenty on the wall with fixed wing



H	By relief
HUP	H=HUP
HCA	H+46
HF	HCA+46,5

Fig.4 – Twenty with beam and fixed wing

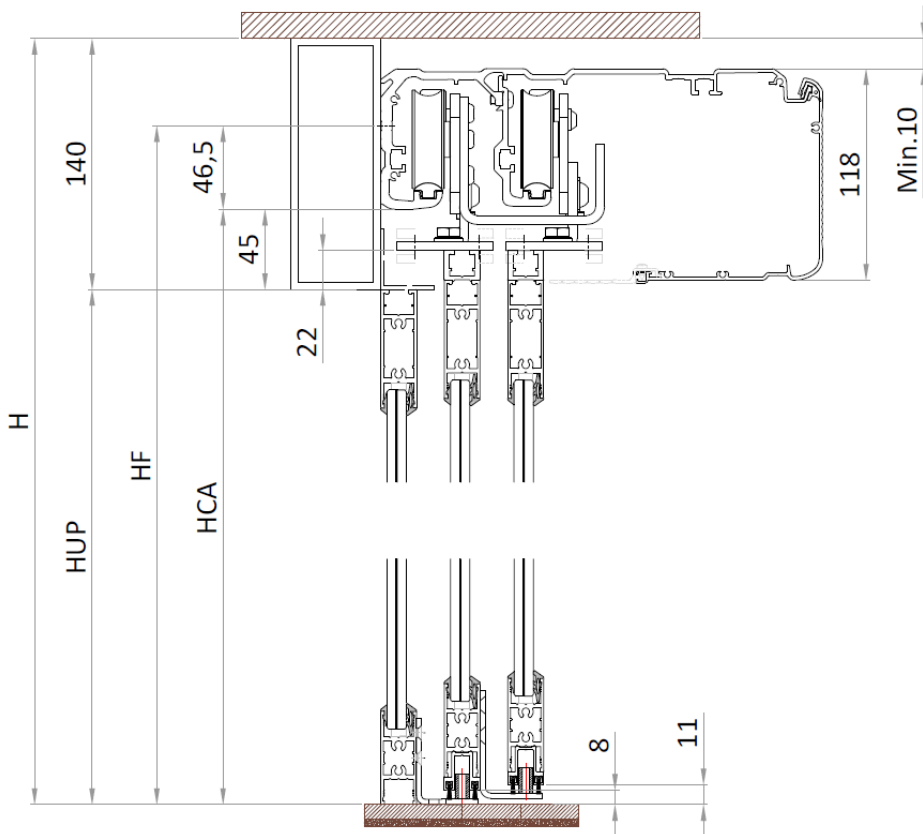

H	By relief
HUP	H-140
HCA	HUP+46
HF	HCA+46,5

Fig.5 – S30 with fixed wing

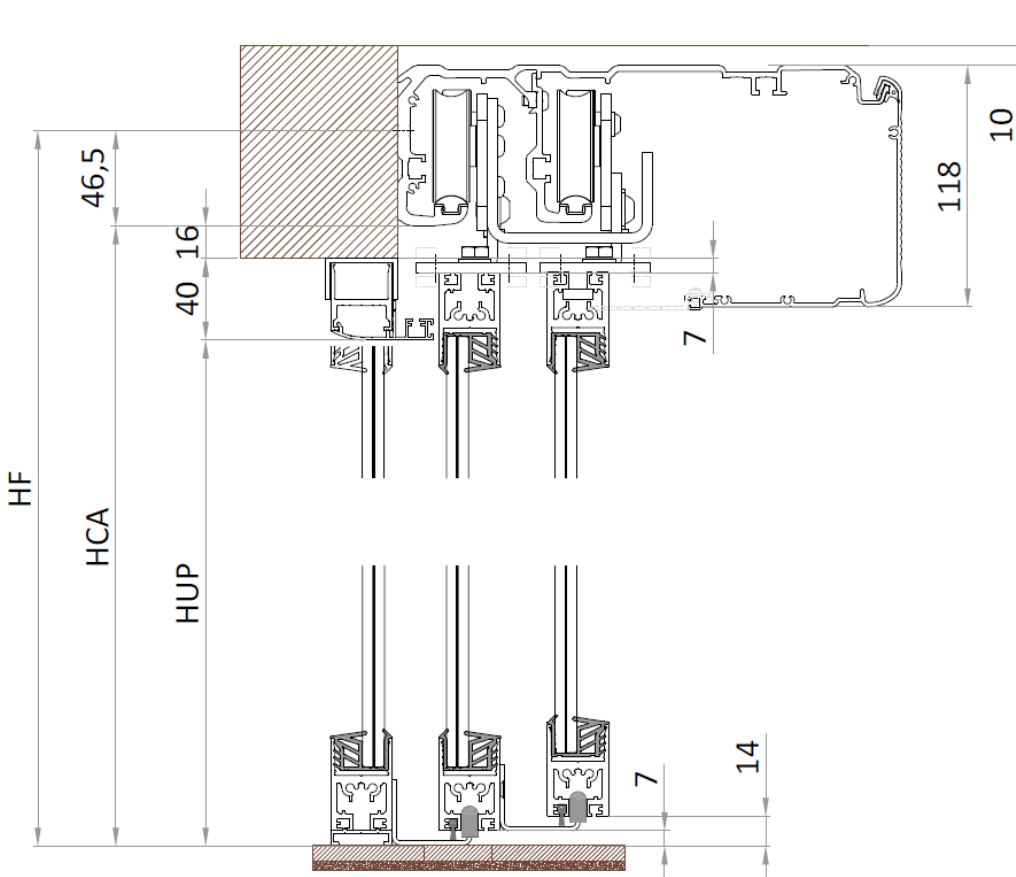

H	By relief
HUP	H-40
HCA	H+17
HF	HCA+46,5

Fig.6 – S30 sliding only

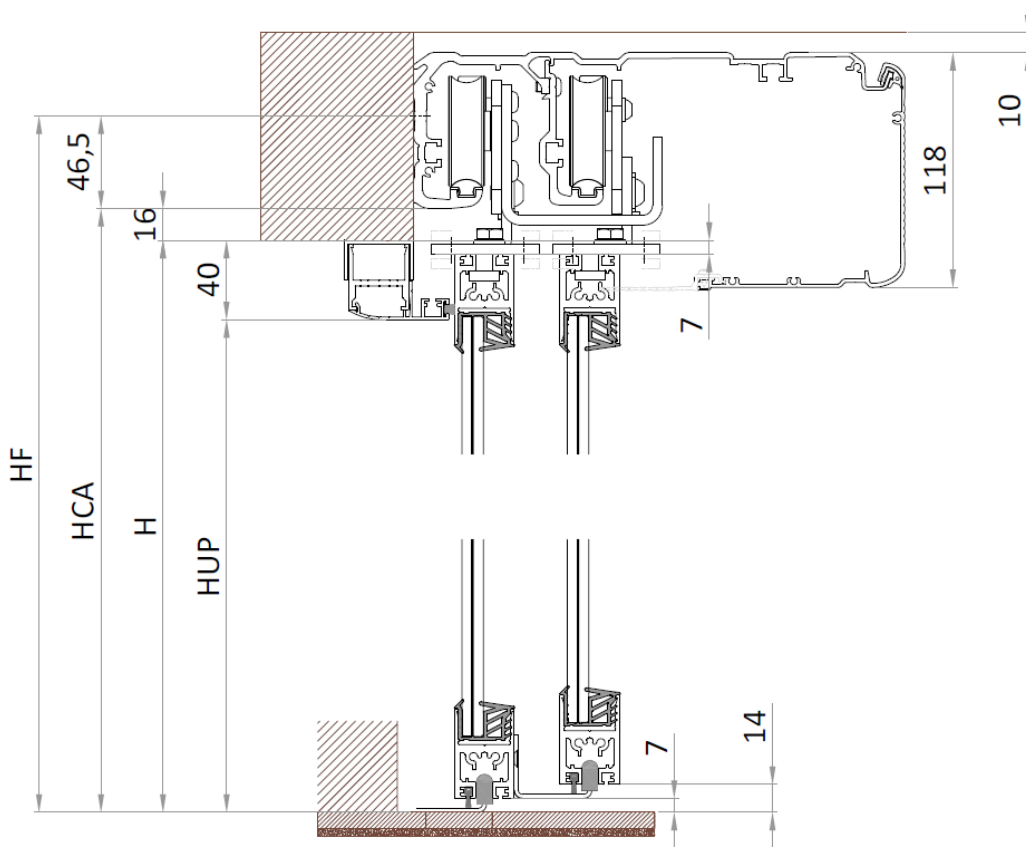

H	By relief
HUP	H-40
HCA	H+17
HF	HCA+46.5

Fig.7 – Magnum sliding only

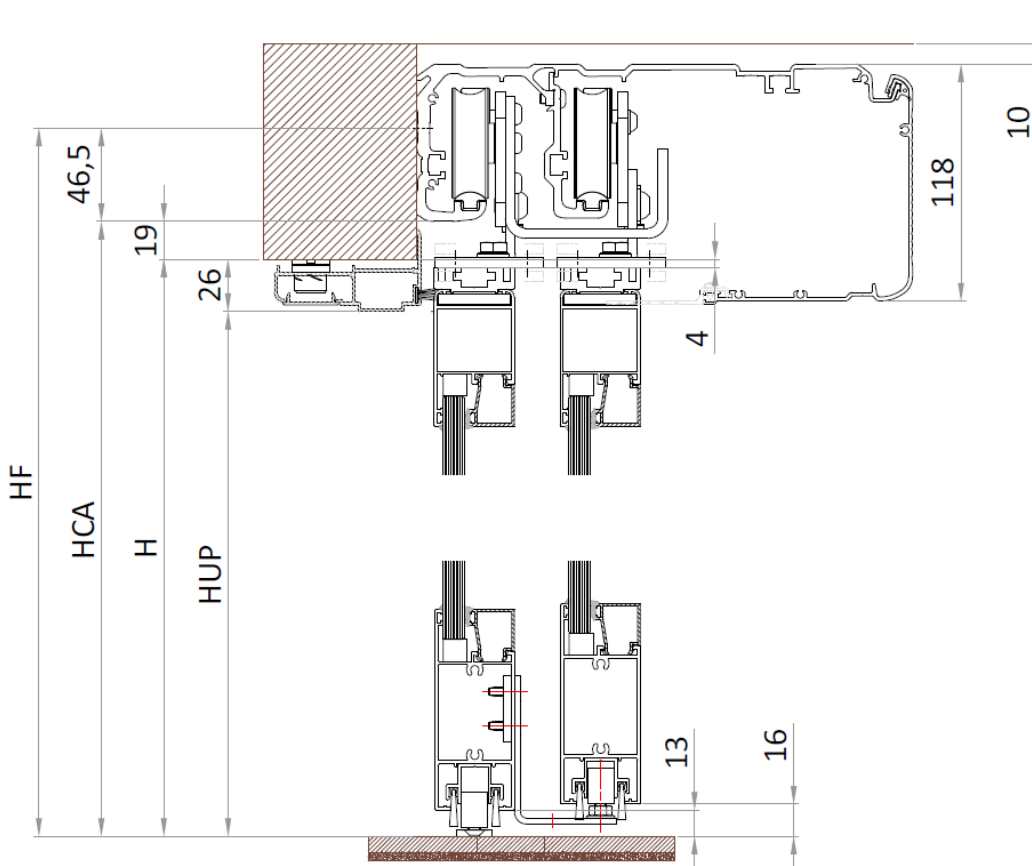

H	By relief
HUP	H-26
HCA	H+19
HF	HCA+46.5

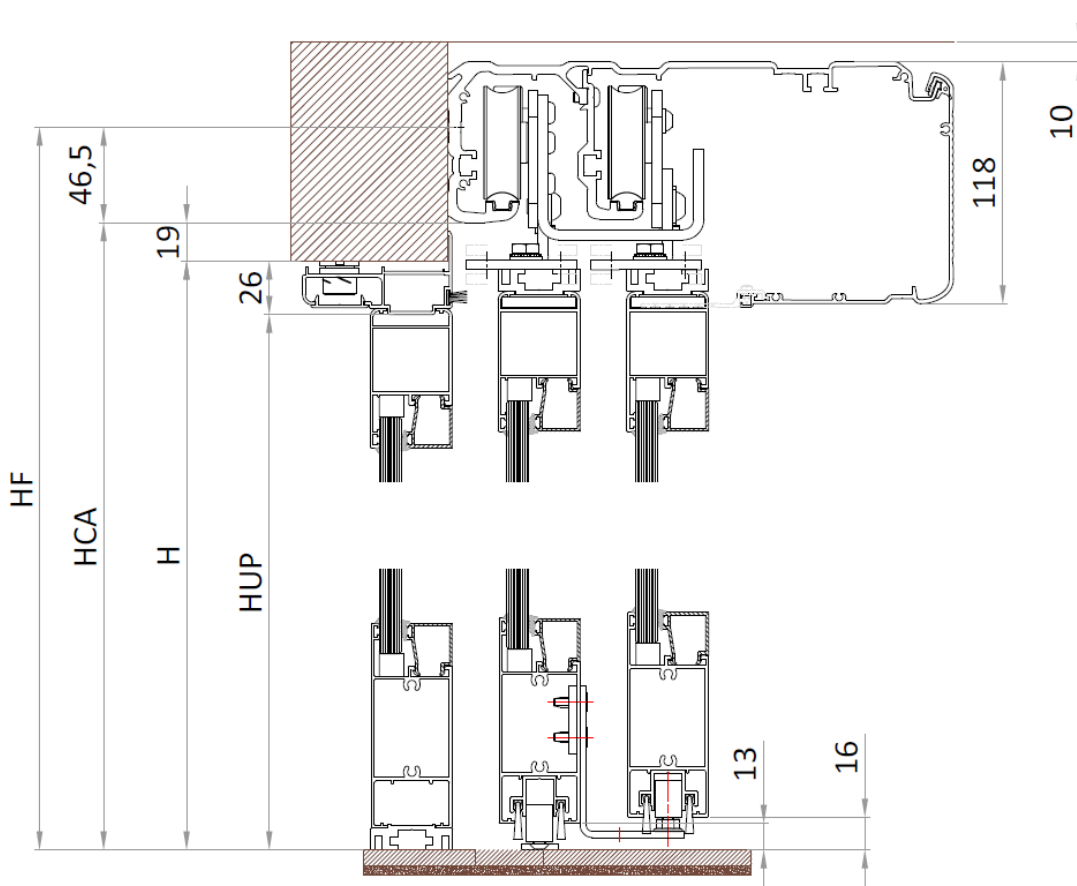
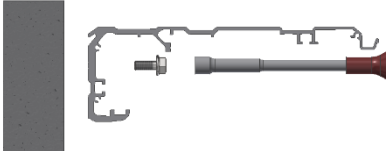
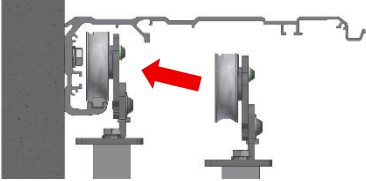
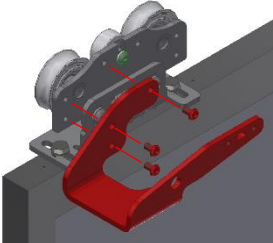
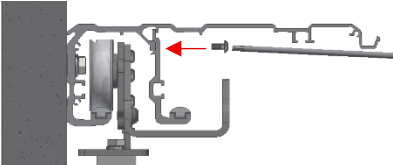
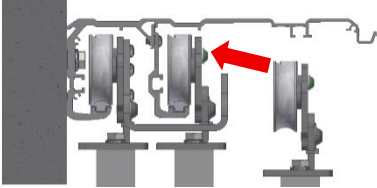
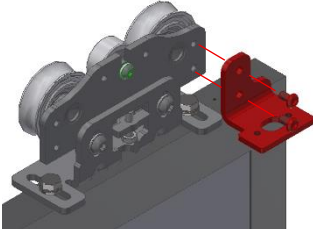

Fig.8 - Magnum with beam and fixed wing



H	By relief
HUP	H-26
HCA	H+19
HF	HCA+46.5

6.2.1. TABLE OF OPERATIONS TO BE PERFORMED FOR ASSEMBLY

After removing the components from the crossbar and the sliding guide profile of the high-speed wing, proceed with the installation by following the steps indicated in the tables in sequence:

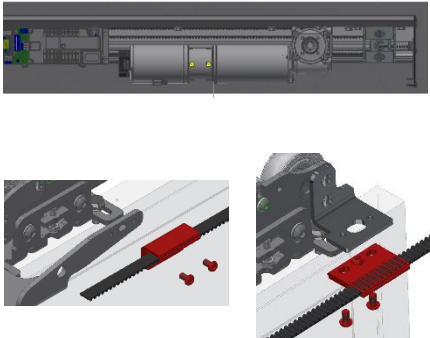
N.	DESCRIPTION	IMAGE	CHAPTER
1	Track fixing		6.2.2
2	Installation and adjustment of the wing/wing (6.2.3) Carriage assembly and adjustment (6.2.7)		6.2.3 – 6.2.7
3	Fixing of the slow wing belt clamp support		6.2.4
4	Mounting of the sliding rail for fast wing		6.2.5
5	Installation and adjustment of the wing/fast wing (6.2.6) Carriage assembly and adjustment (6.2.7)		6.2.6 – 6.2.7
6	Fastening of the fast door belt clamp support		6.2.8
7	Repositioning of components and belt tensioning + fast and slow fastening of the belt-press doors/door.  Carefully follow the instructions for positioning the belt press		6.2.9

6.2.2. TRACK FIXING



Failure to comply with the instructions relating to the fixing of the box may compromise the stability of the fixing itself with consequent detachment and fall of parts. It is necessary to carefully check the support structure, the tightness of the fixing screws or dowels and in track of doubt, stop the installation and carry out more in-depth investigations.

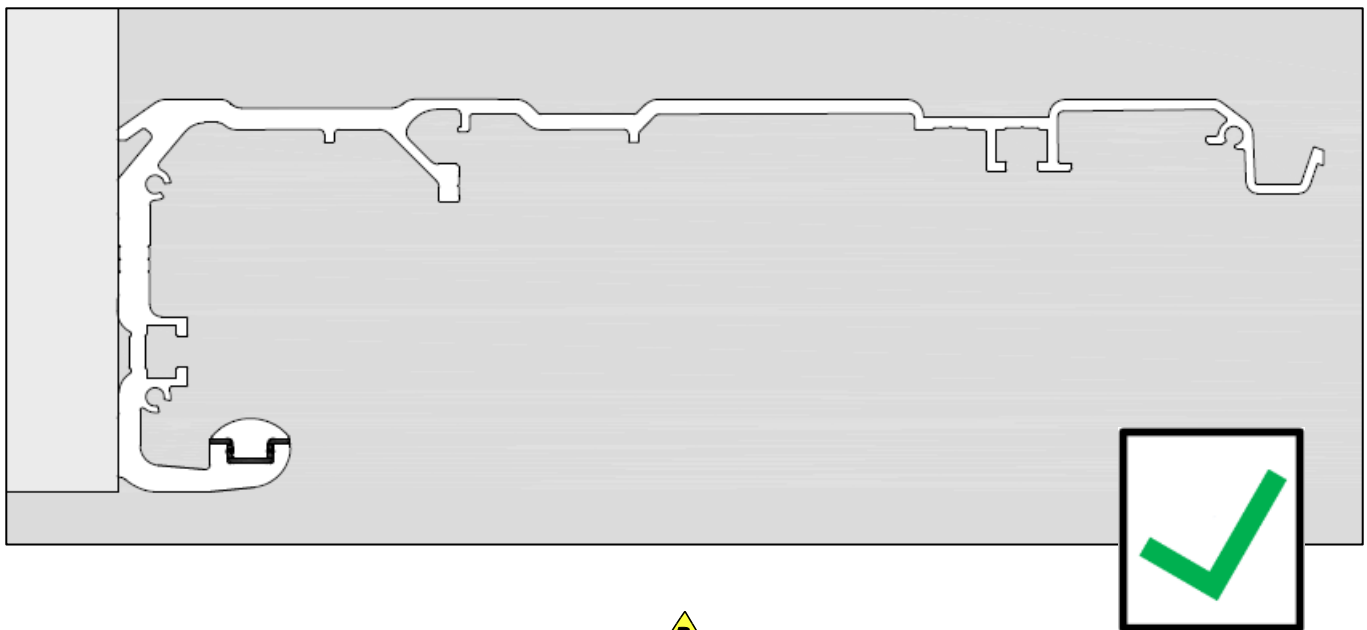
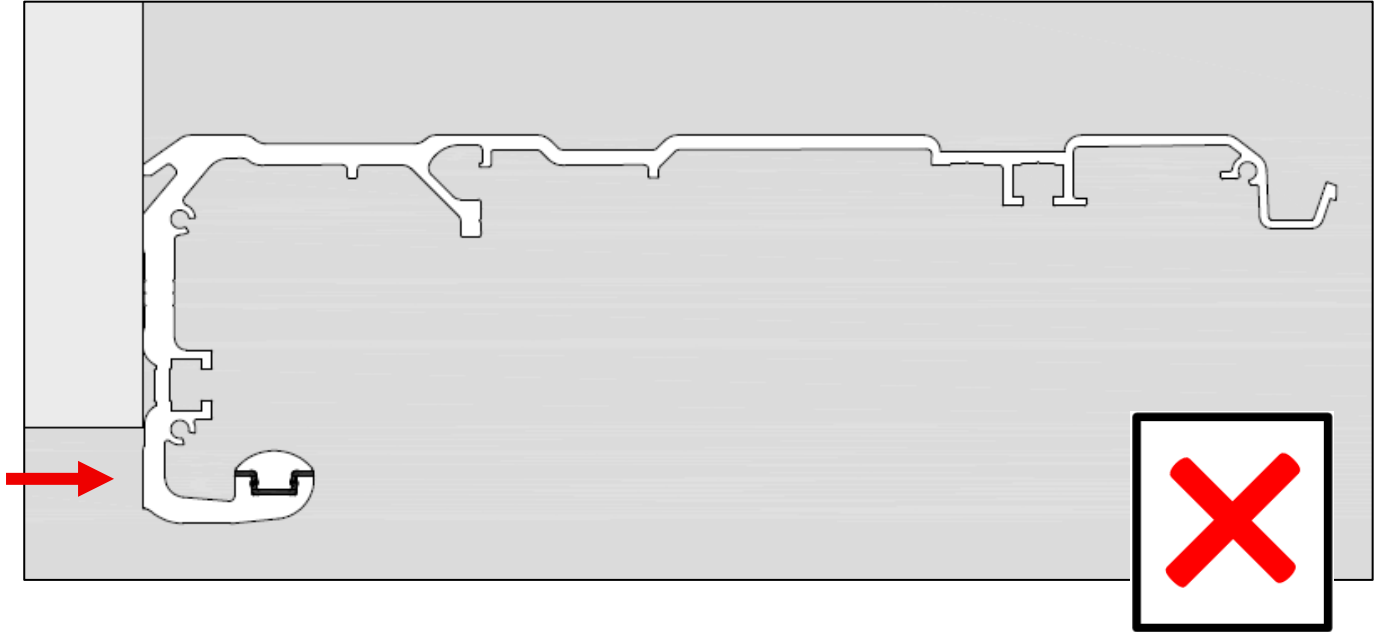

Before tightening the box fixing screws, make sure that the beam is "level" in the direction of length and depth as shown in the figure. Positioning errors could compromise the correct functioning of the operator and constitute a source of danger.

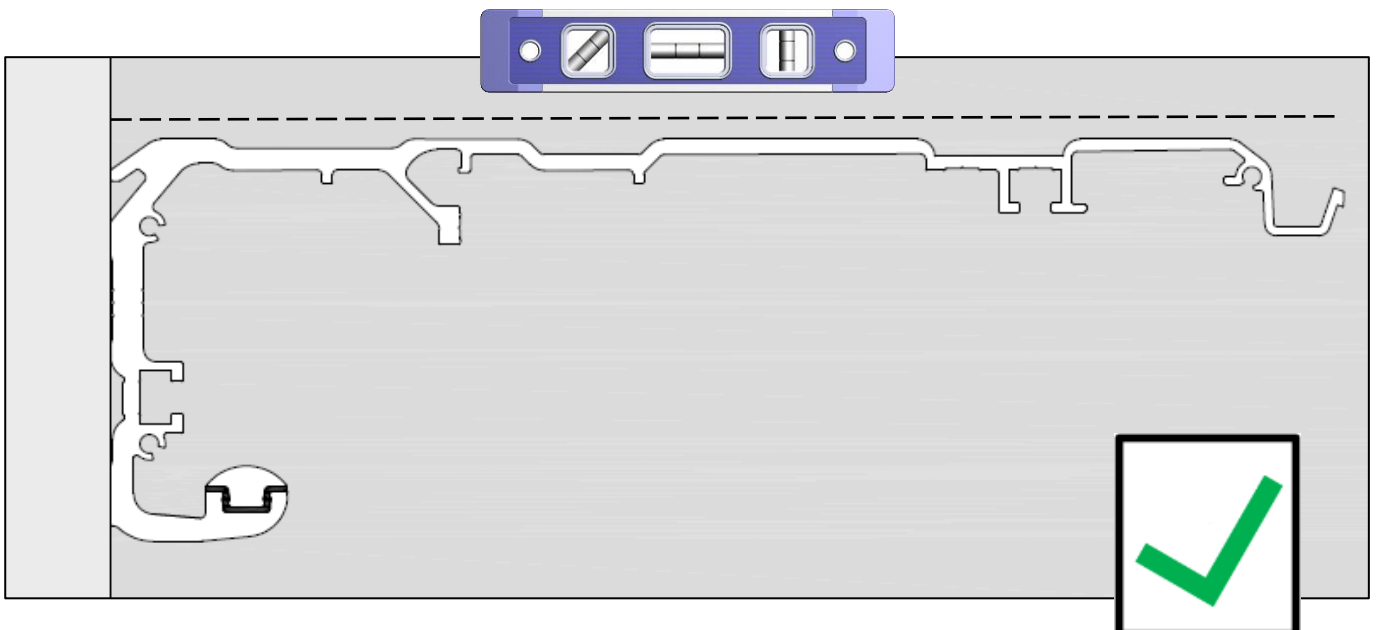
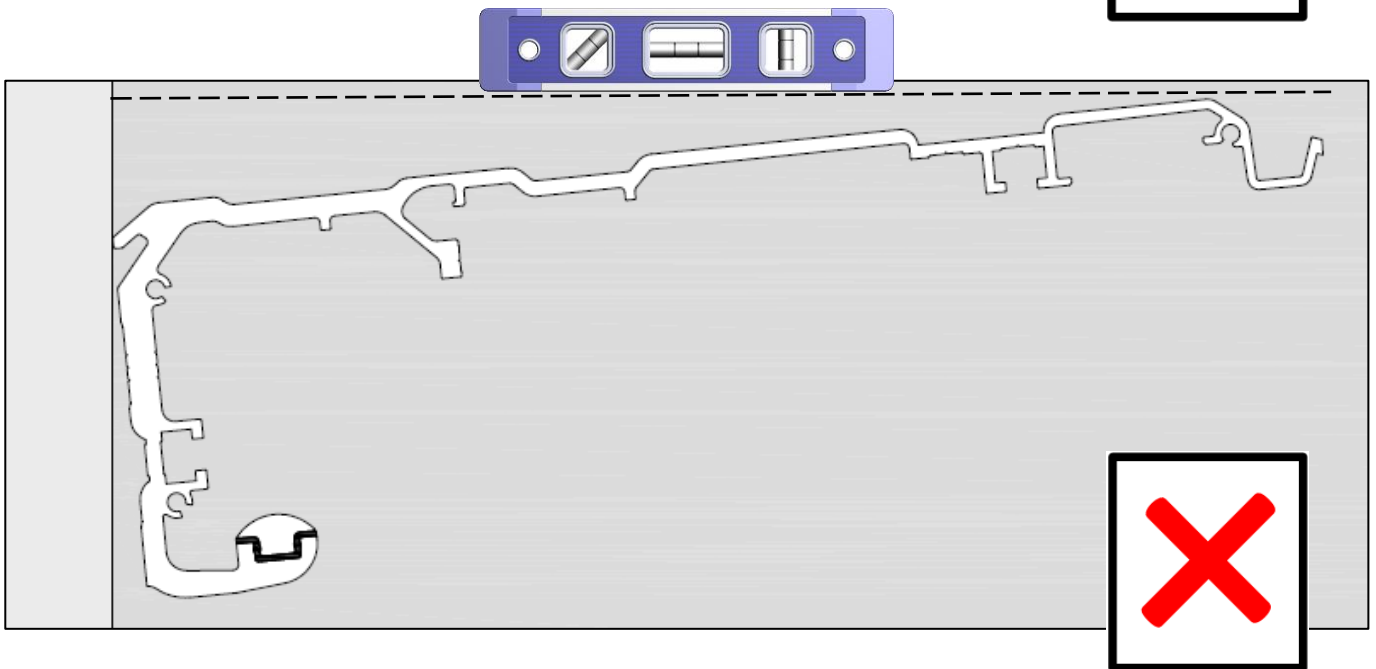
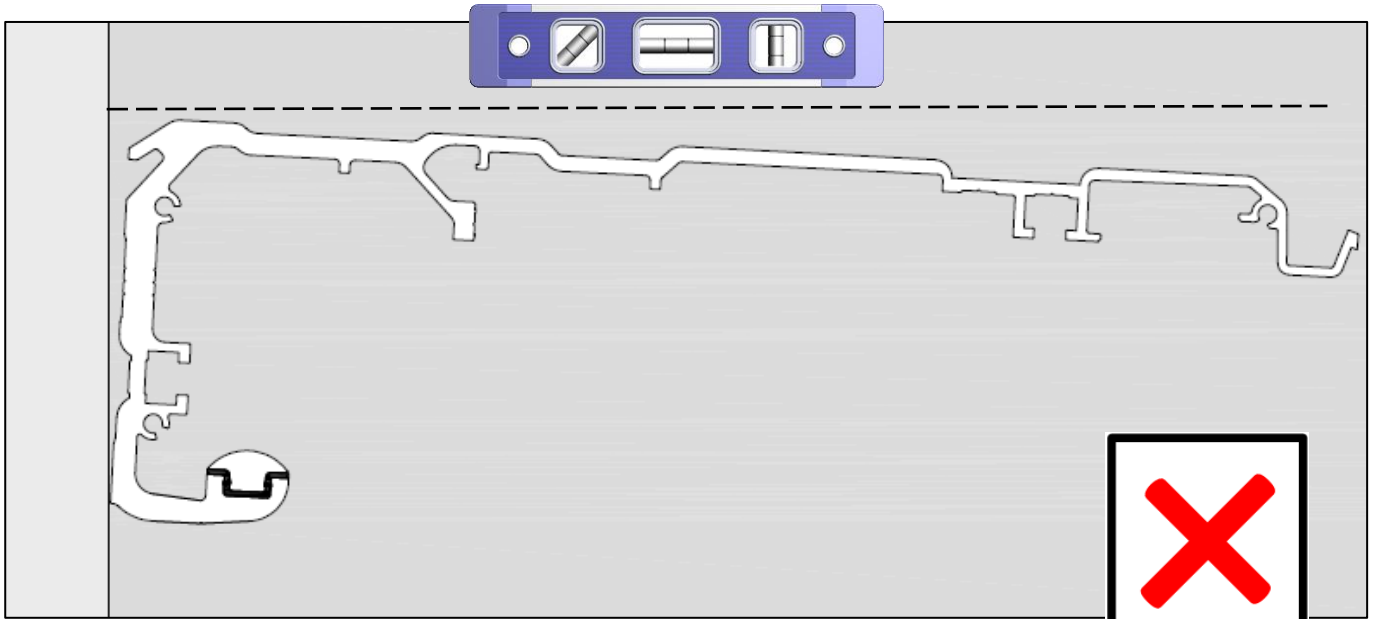

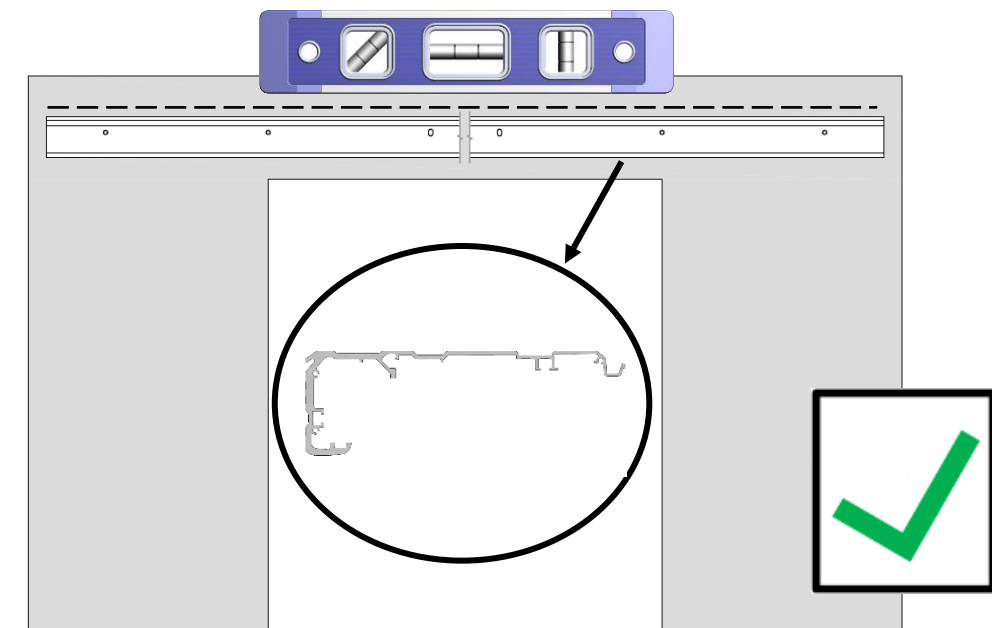
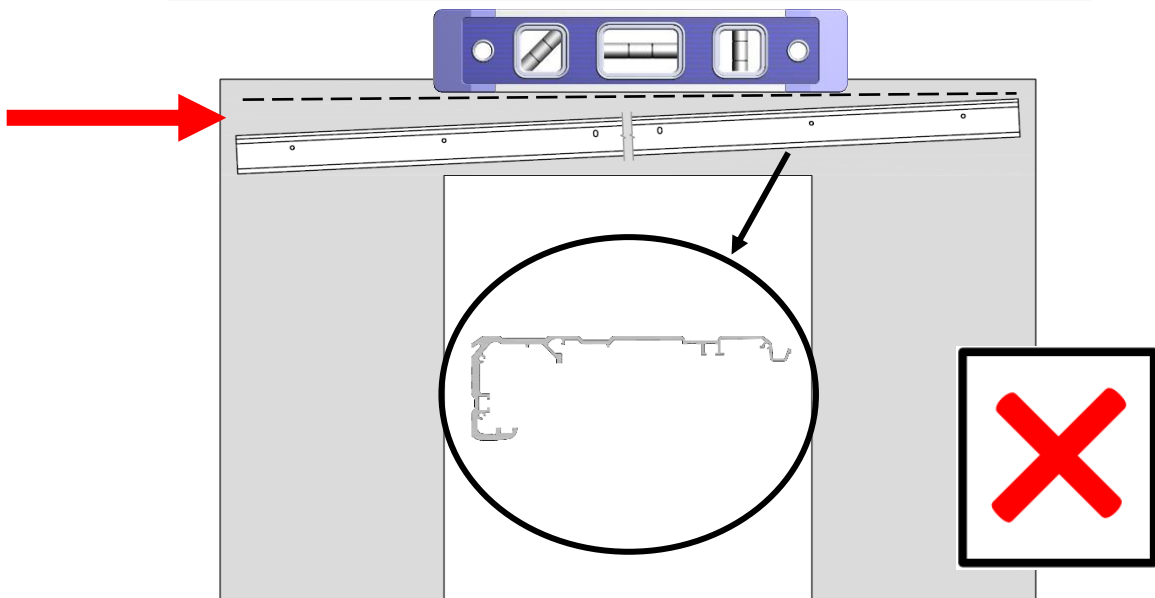
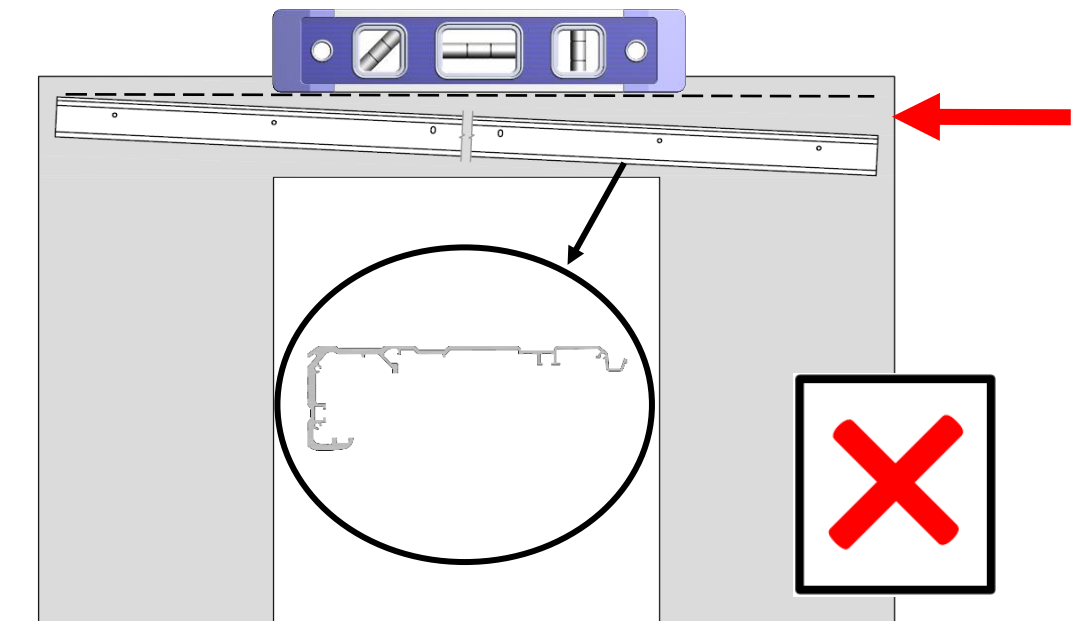



The track must not follow the deformations of the wall, Insert shims in the fixing points to maintain straightness

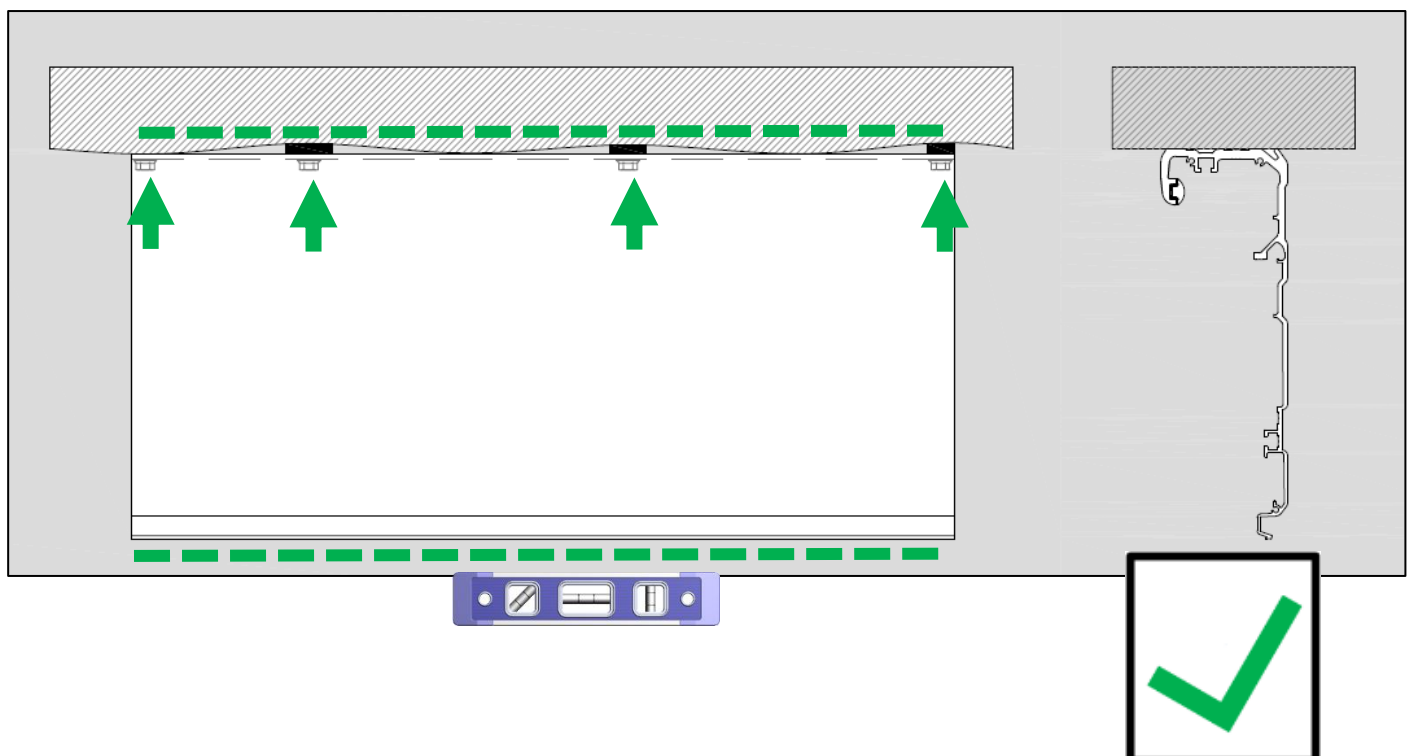
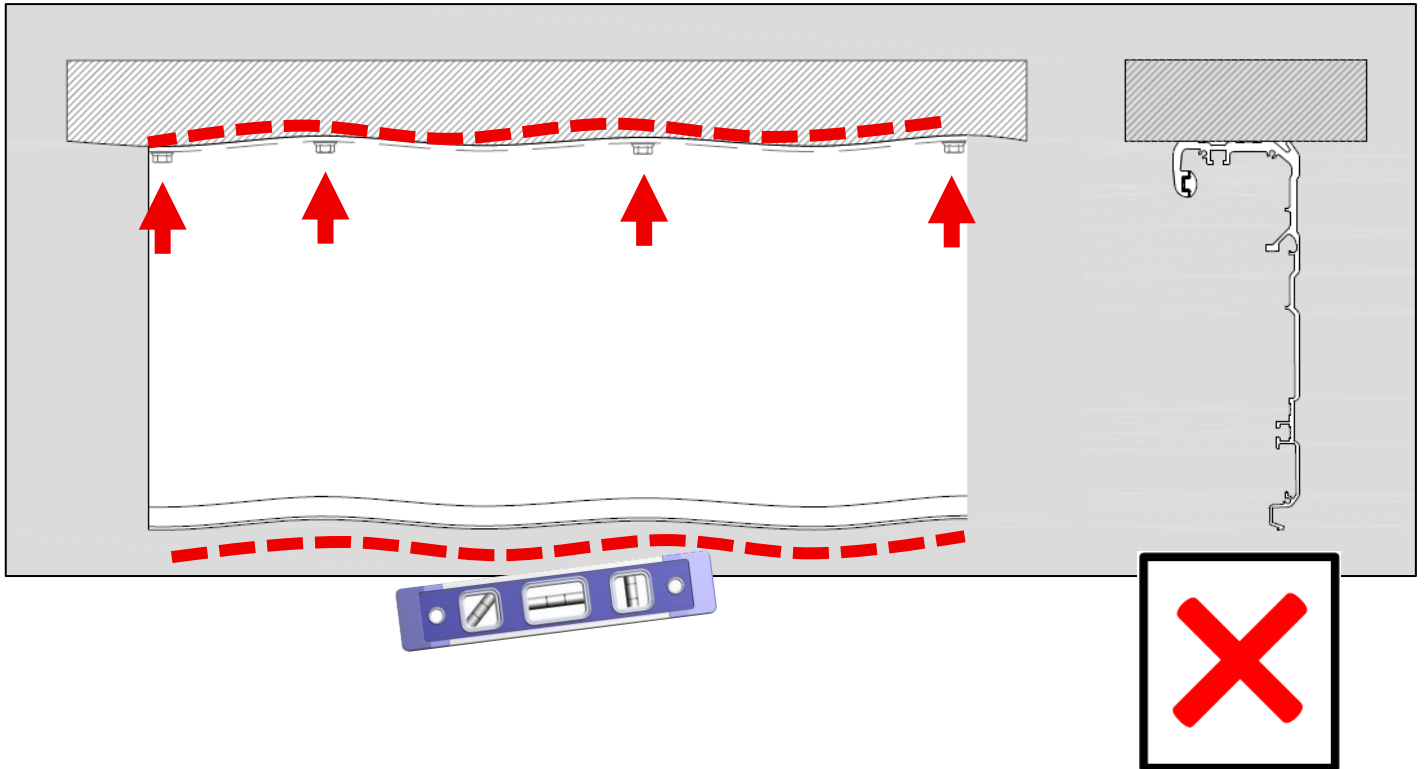



The track must be fixed using all the slots/holes provided in the aluminium.

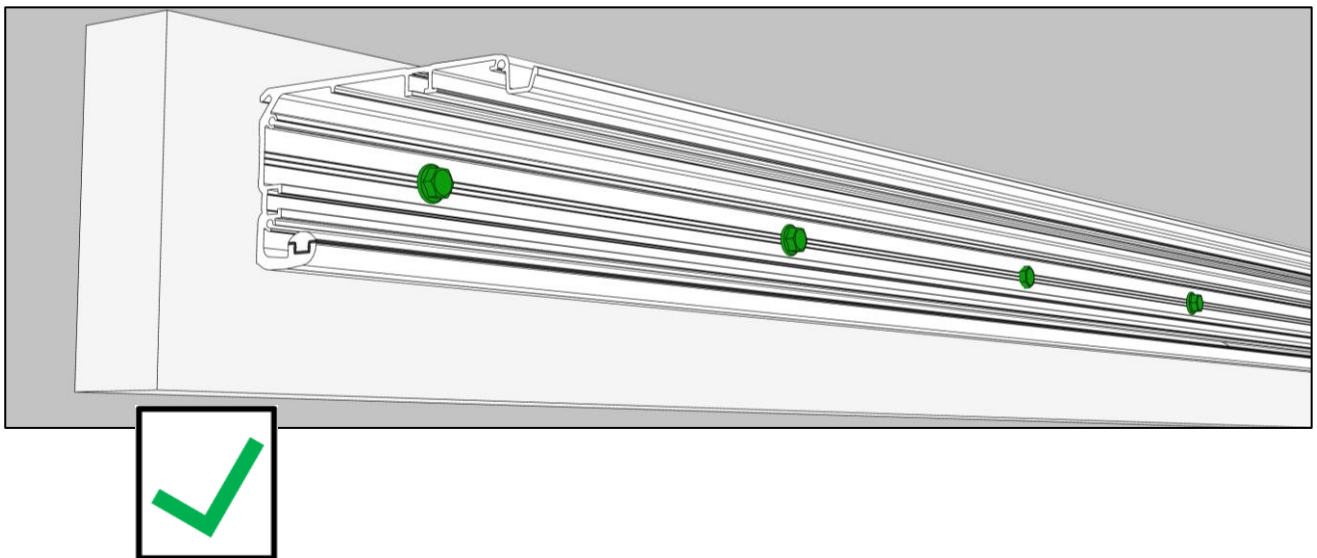
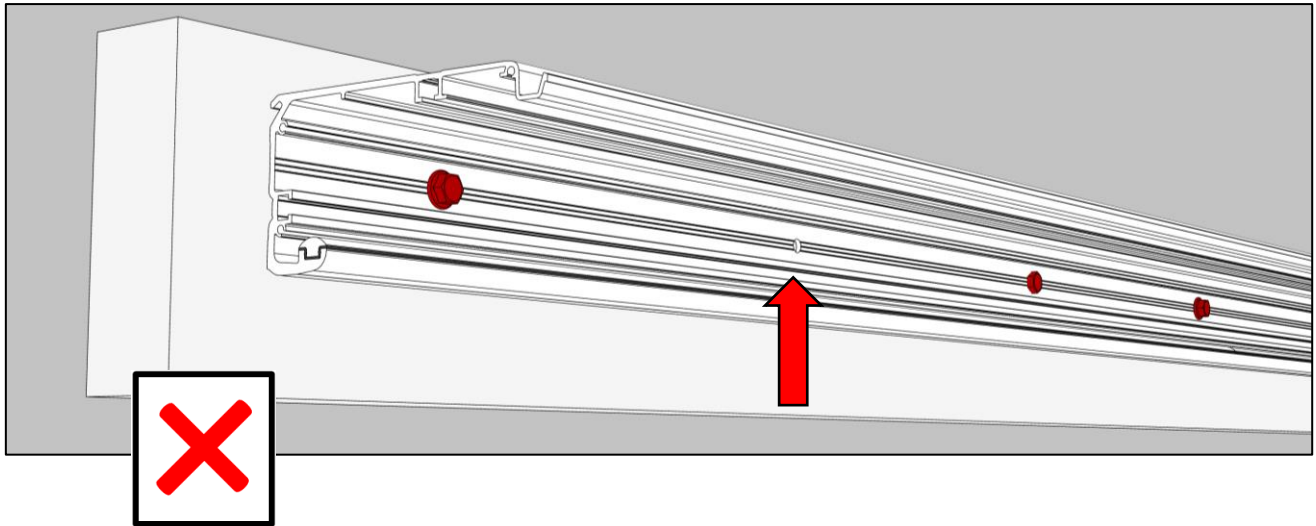

After fixing the box, hang the doors/slow door

6.2.3. ASSEMBLY AND ADJUSTMENT OF WINGS/WING – ASSEMBLY AND ADJUSTMENT OF CARRIAGES

Lift the door and gently position the wheels of the carriages on the sliding guide, taking care not to damage parts with violent impacts.

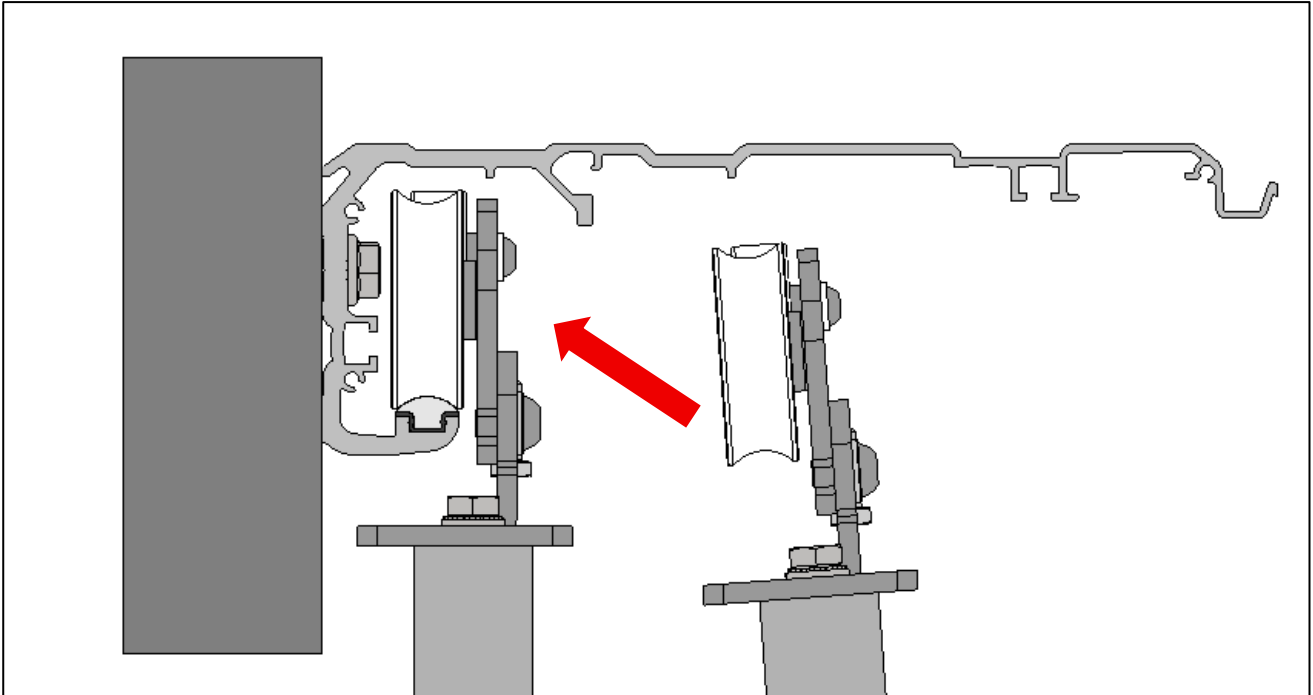

The slow leaf must be adjusted DEFINITELY: height, sliding, skids, carriages, anti-derailment, etc.



The carriages must be assembled and adjusted according to the dedicated paragraph: 6.2.7 CARRIAGE INSTALLATION

6.2.4. FASTENING OF THE BELT CLAMPING SUPPORT/SLOW WINGS

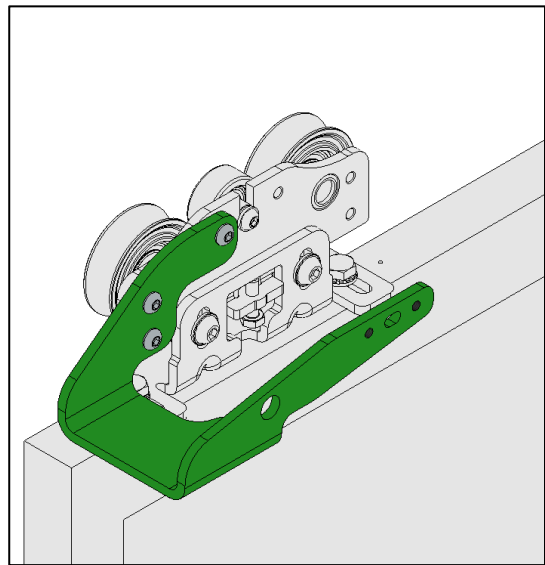
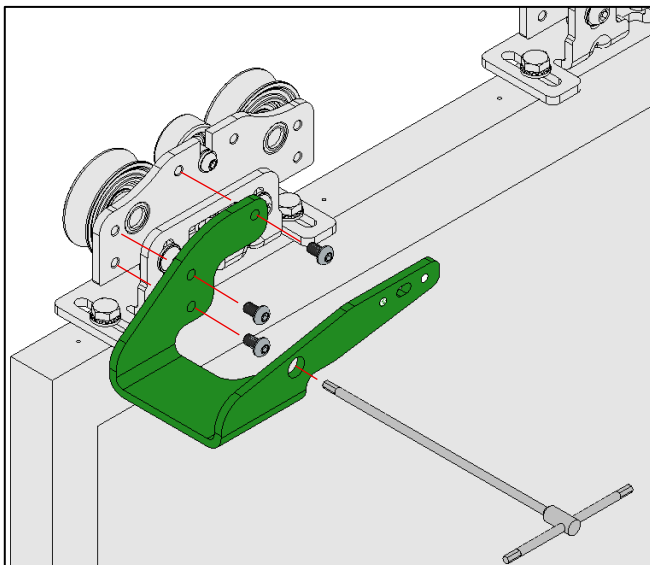

4 – 10,3Nm - Viti TBEI M6x10

ERT80 2 LEFT sliding configuration:
Slow sash opens to the left

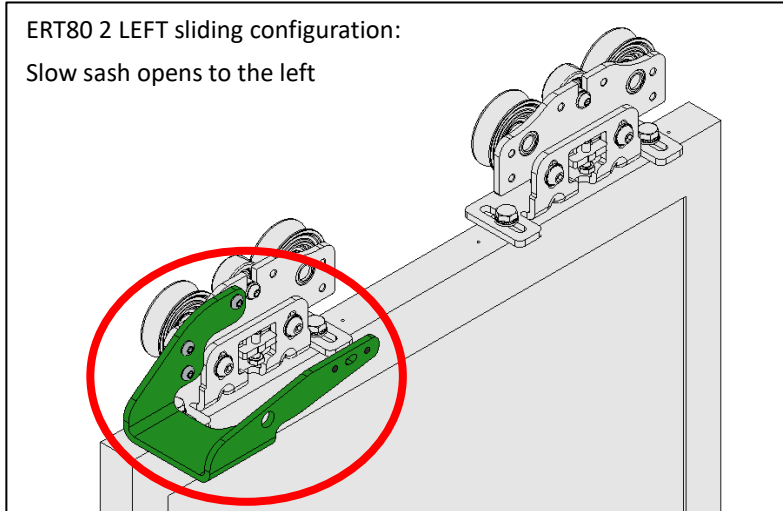

ERT80 2 Sliding RIGHT configuration:
Slow sash opens to the right

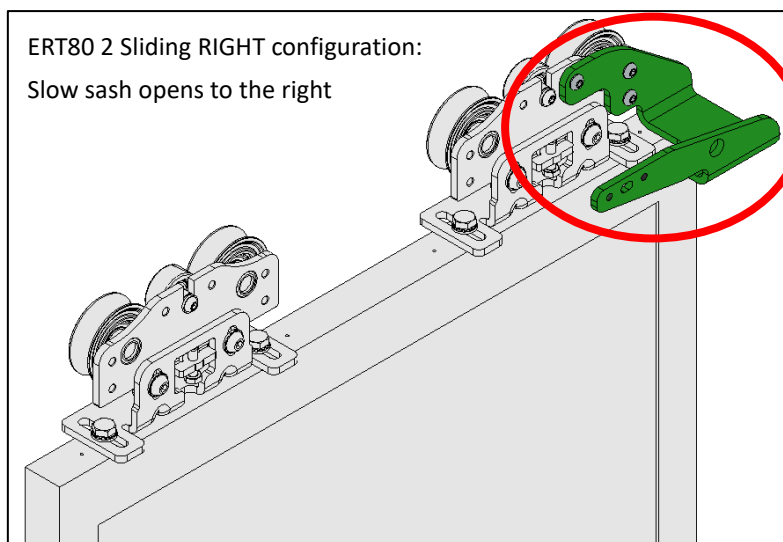

ERT80 4 sliding configuration:
Slow Wing

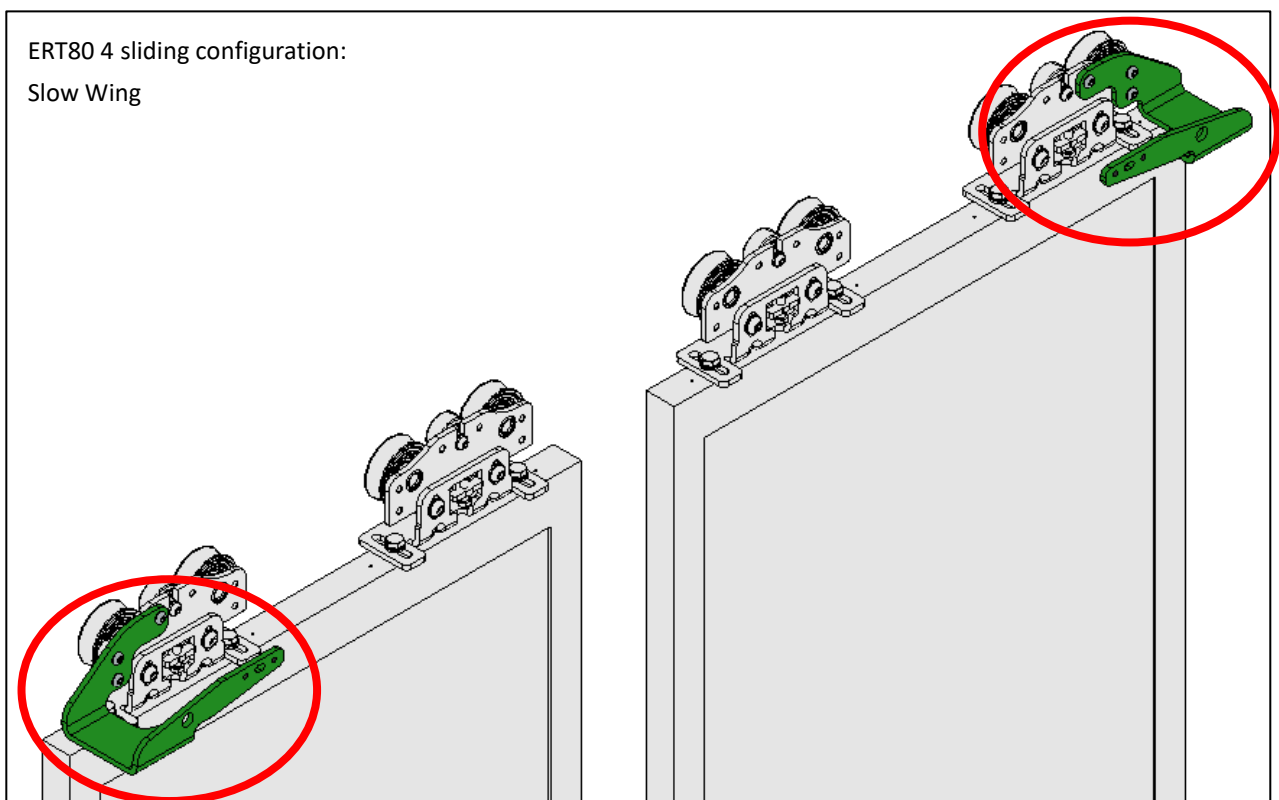

6.2.5. INSTALLATION OF THE SLIDING GUIDE FOR FAST WING

To insert the guide into the dedicated slot, bring the lens door(s) to the bottom of the track, pass the guide inside the belt press support and insert it into the slot as shown in the images.

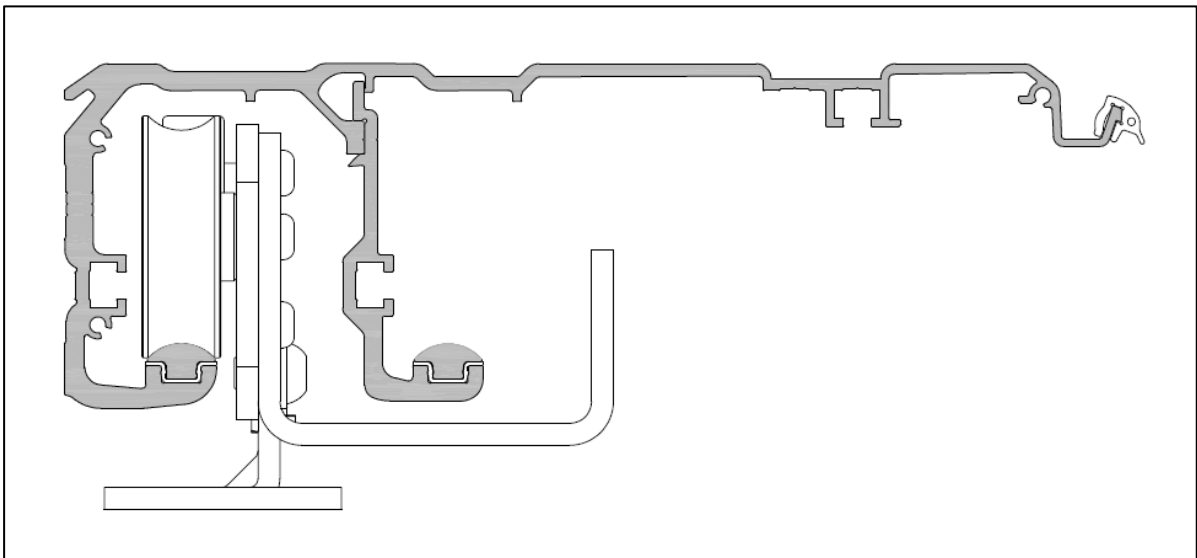
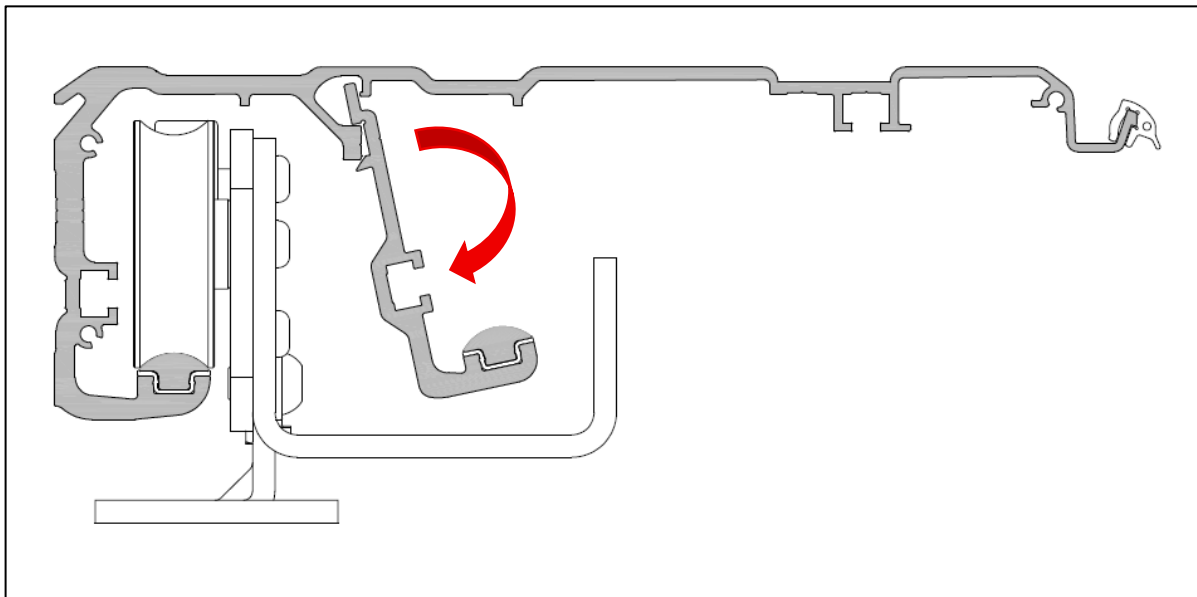
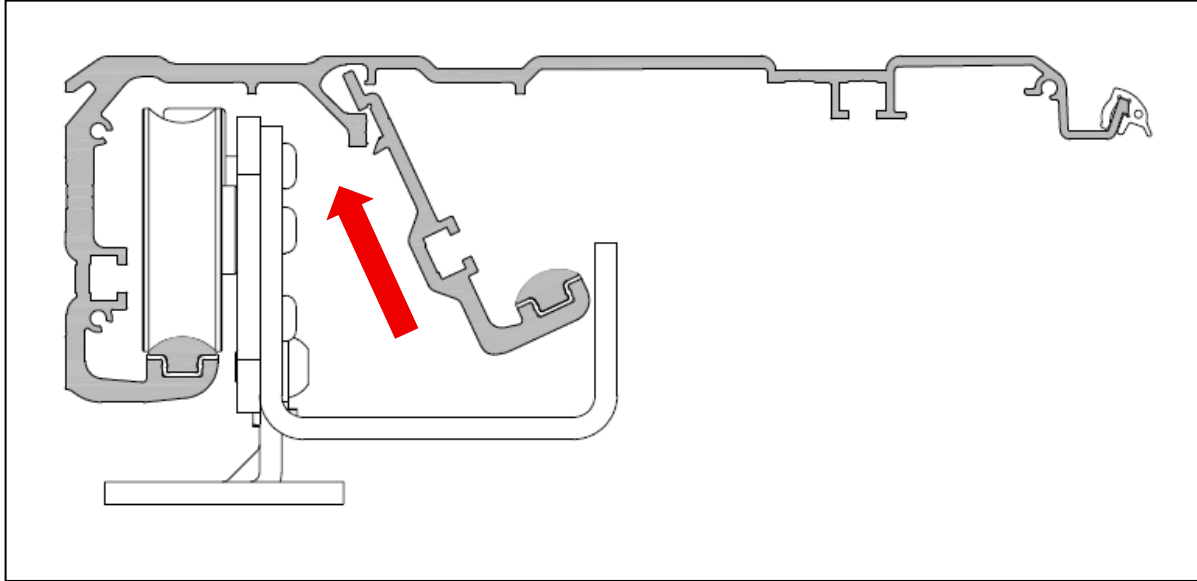



WARNING!!! Always check that the hook is correctly resting in the points indicated in the green tick image

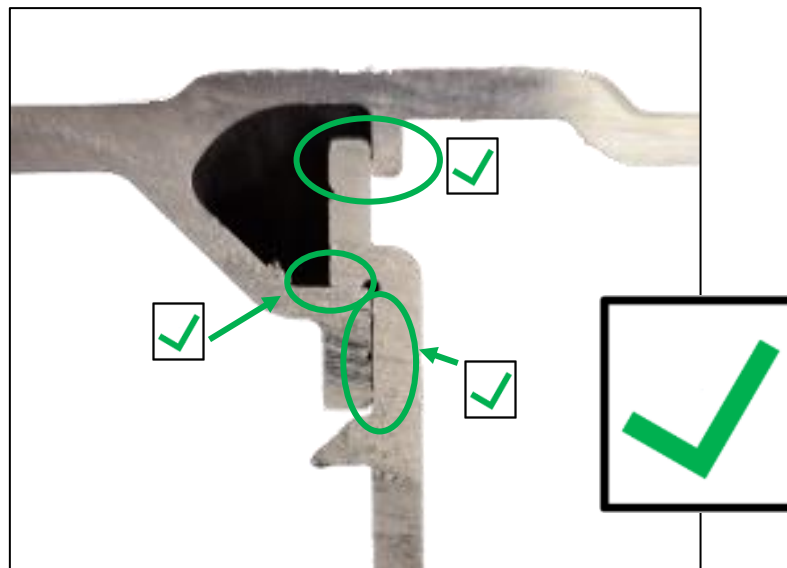
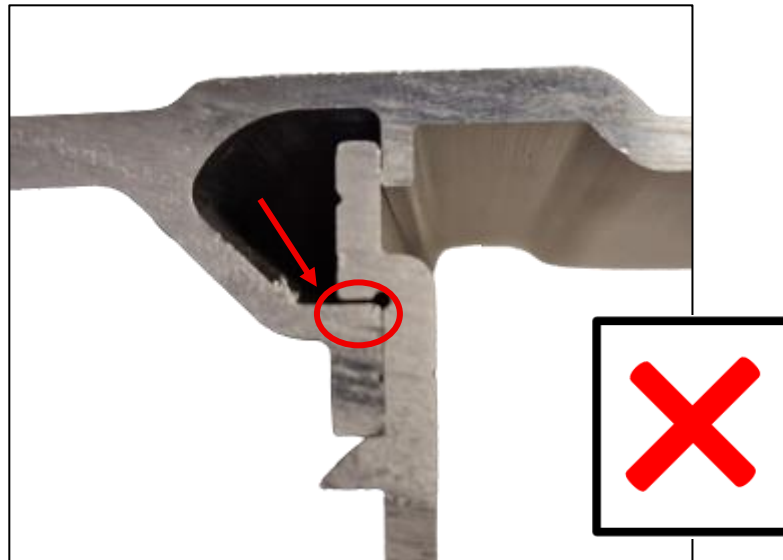
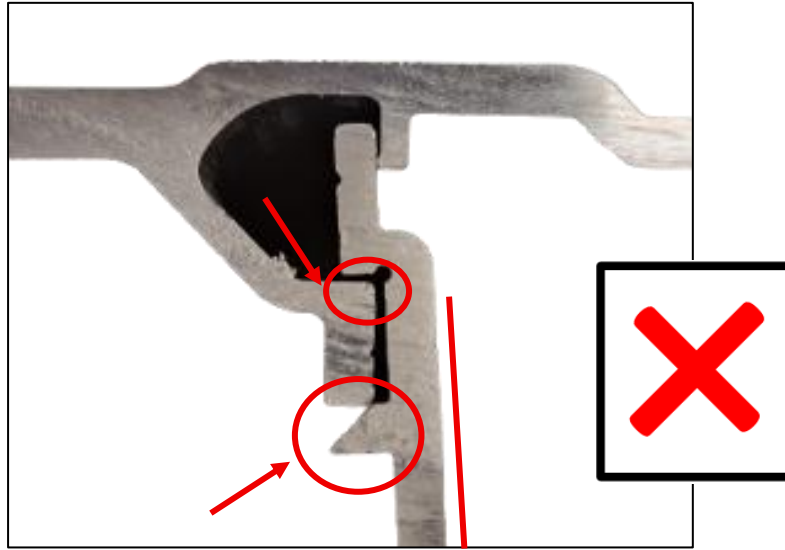



Secure the guide with the appropriate screws. The guide must be fixed using all the holes provided in the aluminum.

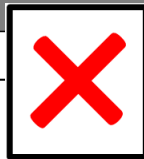
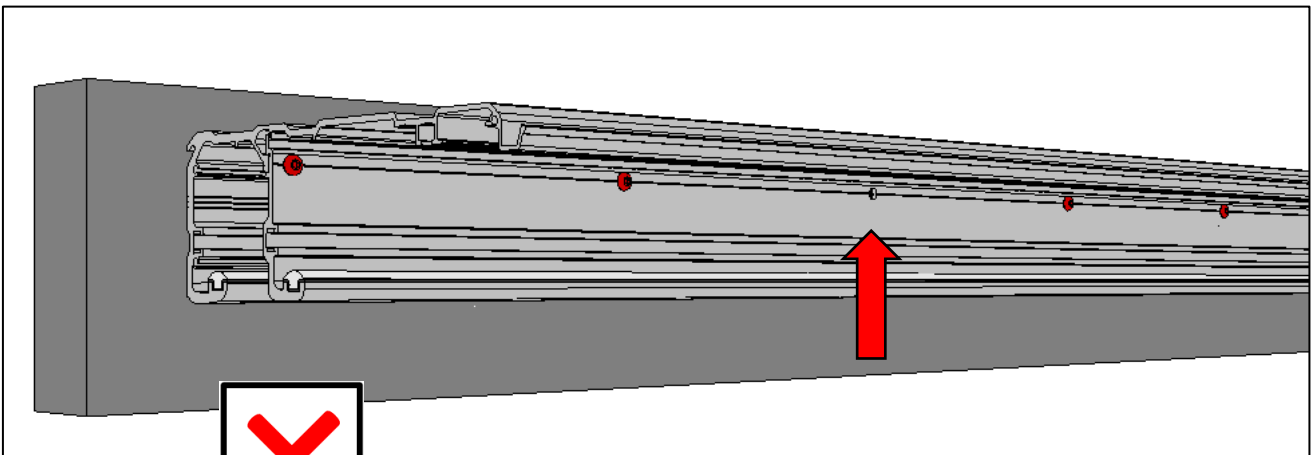
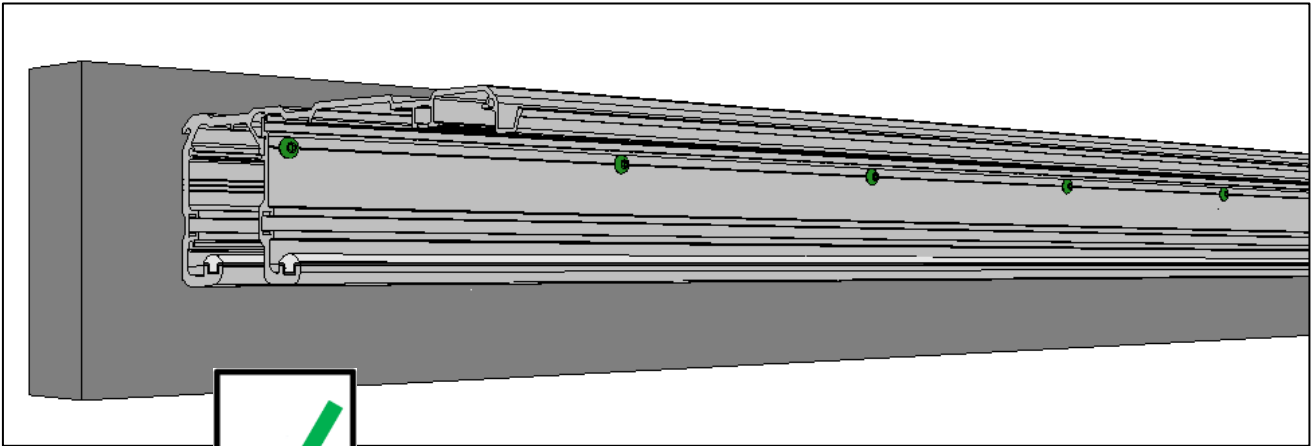

3 – 6Nm - Screws TBEI M5x10



Observe tightening torque to avoid stripping the thread on the aluminium
Use an Allen key with a ball head as shown in the picture



6.2.6. QUICK WING/WING ASSEMBLY AND ADJUSTMENT – CARRIAGE ASSEMBLY AND ADJUSTMENT

Lift the door and gently position the wheels of the carriages on the sliding guide, taking care not to damage parts with violent impacts.

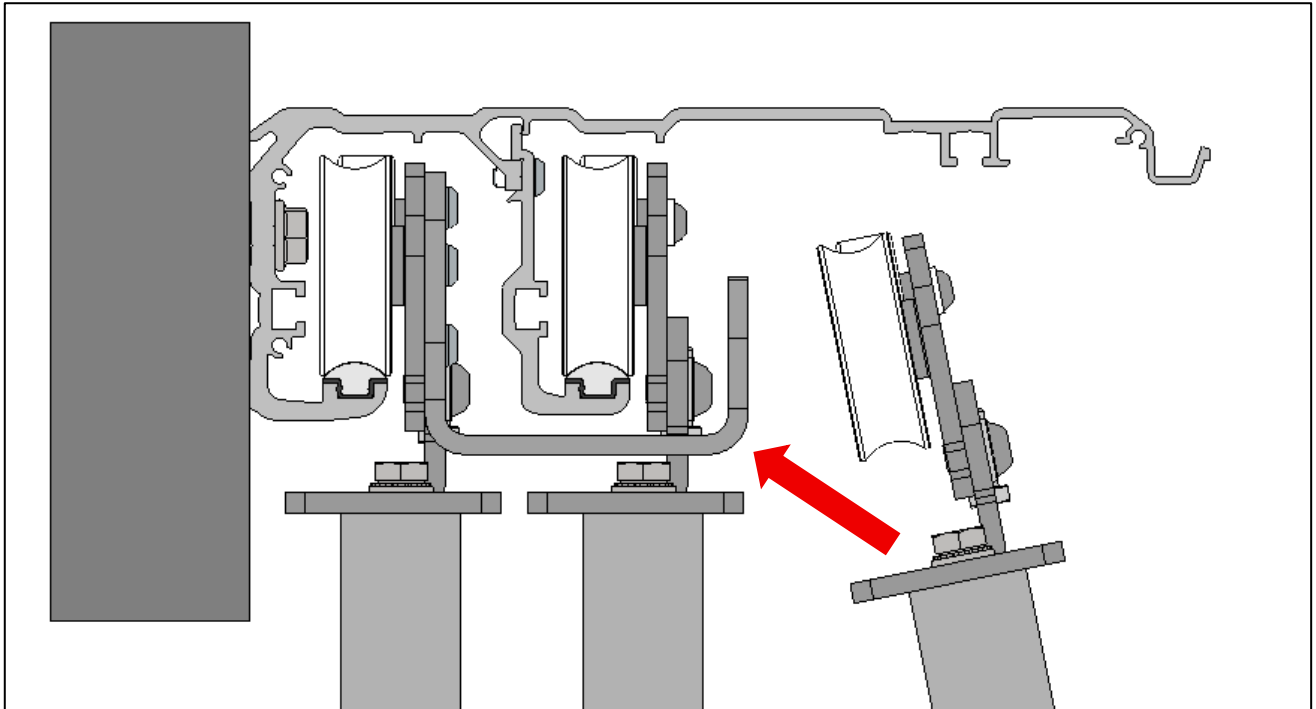

The fast wing must be adjusted **DEFINITELY**: height, sliding, skids, carriages, anti-derailment, limit switches, etc.



The carriages must be assembled and adjusted according to the dedicated paragraph: 6.2.7 CARRIAGE INSTALLATION

Adjust the limit switches with the doors:

- **N.2 sliding wings (Left-Right):** slightly loosen the screws "A", bring the door to close before and move the limit switch until the pad touches the carriage, then tighten the screws "A". Repeat the same operation by opening the door.
- **N.4 sliding wings:** slightly loosen the screws "A", bring the doors to close first and move the limit switch until the pad on the right carriage touches, then tighten the screws "A". Repeat the same operation by opening the doors.

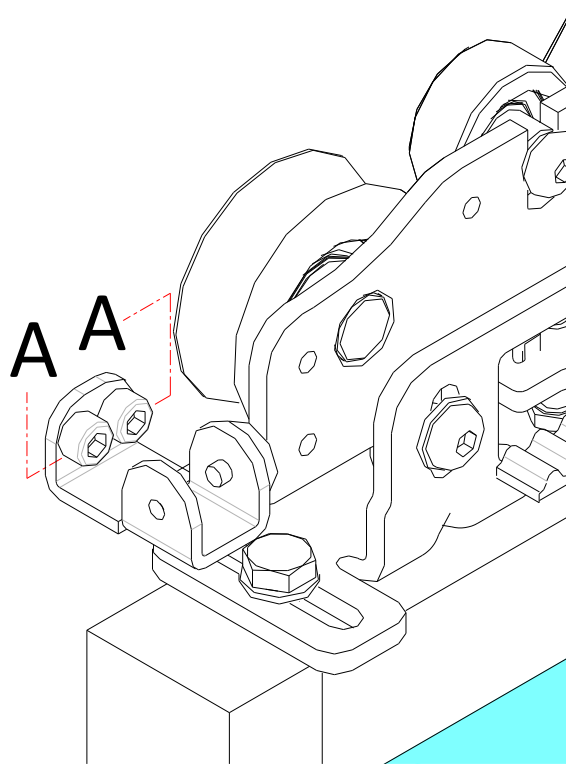

Before starting the operator, check that the screws "A" of the limit switches are correctly tightened

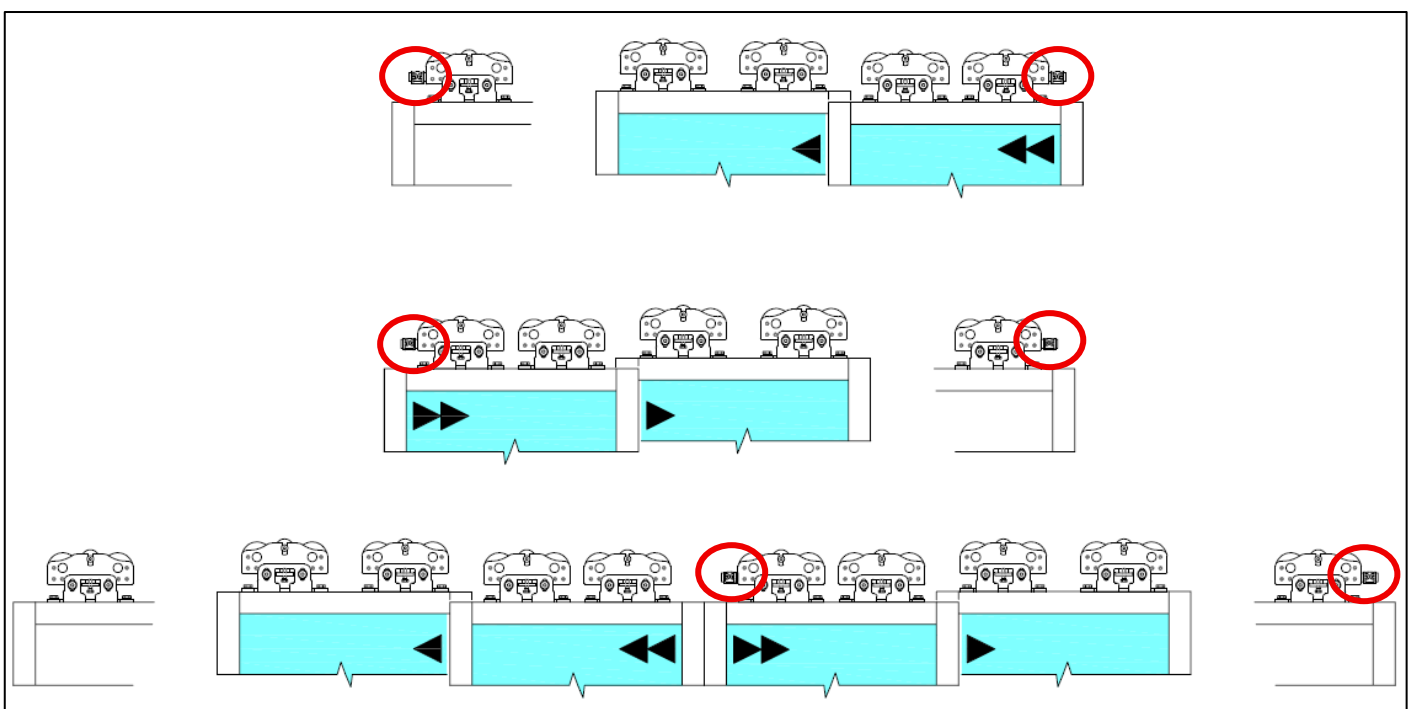

6.2.7. CARRIAGE INSTALLATION

6.2.7.1 CAPACITY

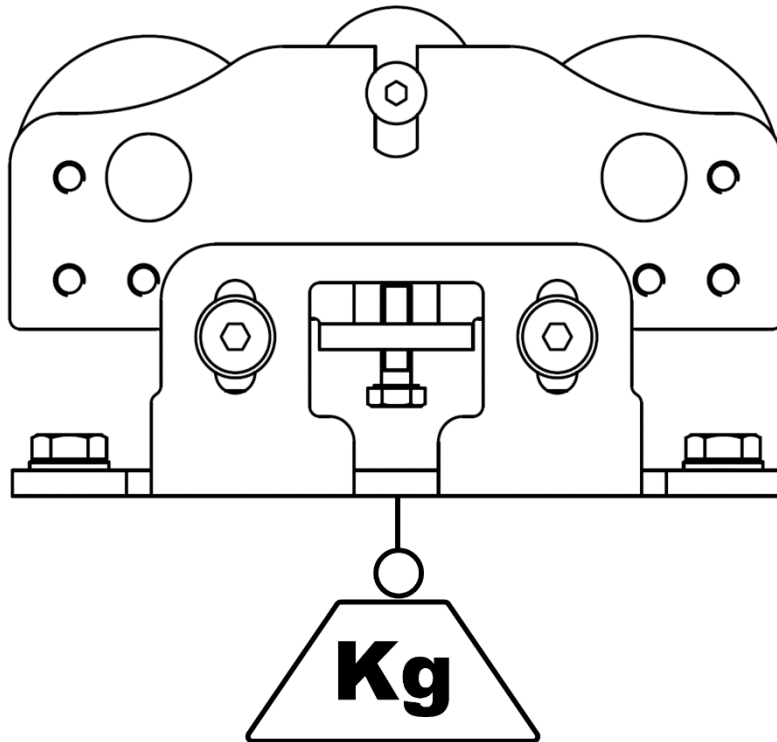

Max capacity 80Kg/carriage

6.2.7.2 INSTALLATION OF CARRIAGES ON WING



Fixing:

Fix the carriages on the door panel using the appropriate M8 screws.



Note 1:

The dimensions shown in the figure refer to wings seen from the inspection side of the operator (cover side).



Note 2:

For door panels equipped with a breakout panic device or full glass doors equipped with special clamps, follow the assembly dimensions given in the manuals of the relevant accessories.

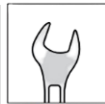
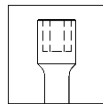
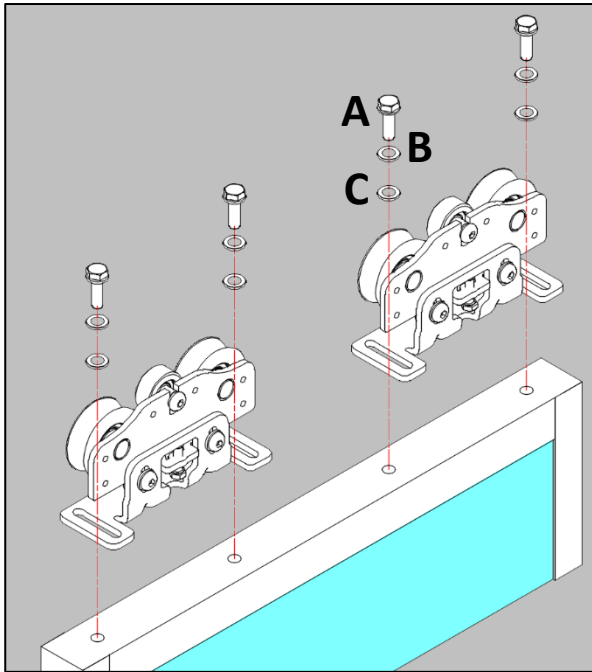

13 ÷ 20.41Nm

A	Hex Head Screws M8x1x16-25
B	M8 Serrated washers
C	M8 Plane Washer

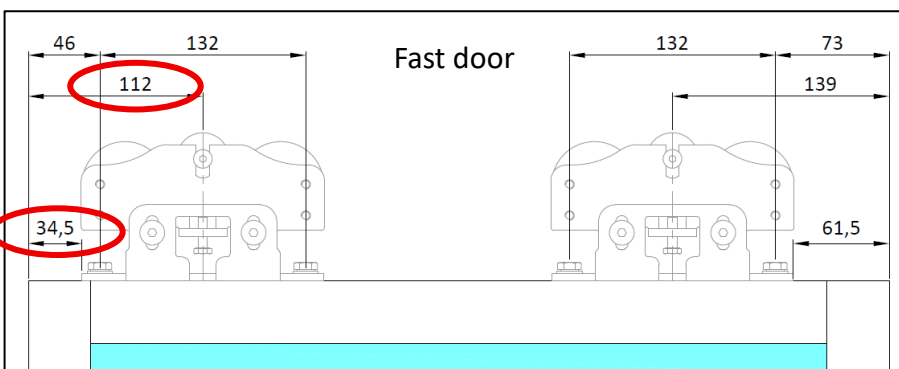
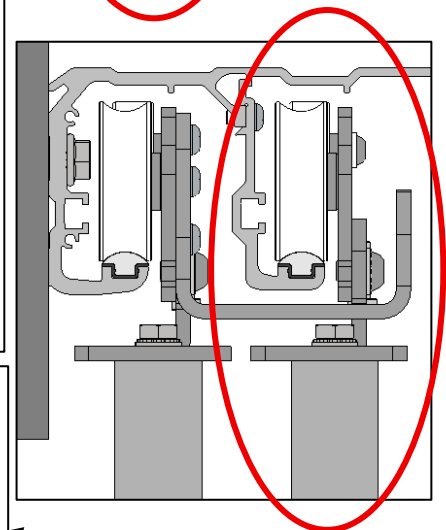
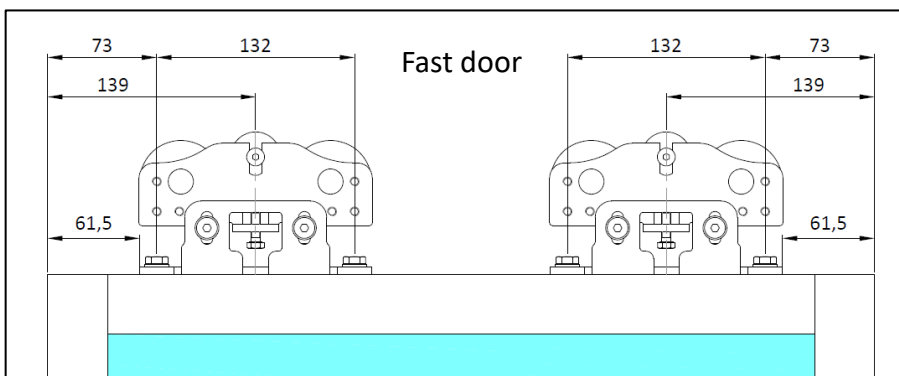
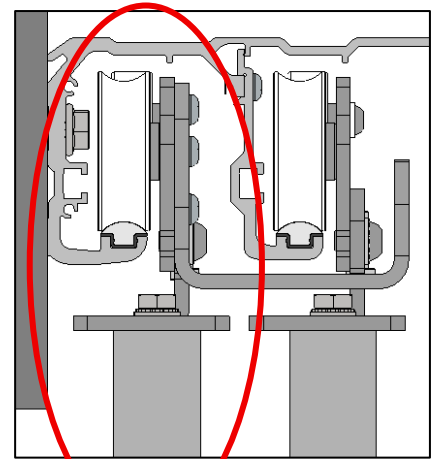
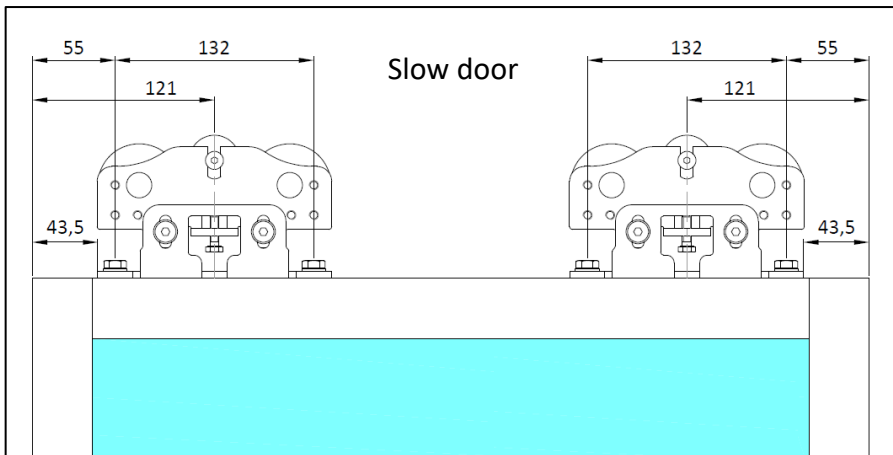

**FOR 2 SLIDING UNITS
ONLY – RIGHT-HAND
OPENING WITH LOCK**

POSITIONING OF THE DOOR IN THE TRACK

Lower the anti-derailment wheels completely.

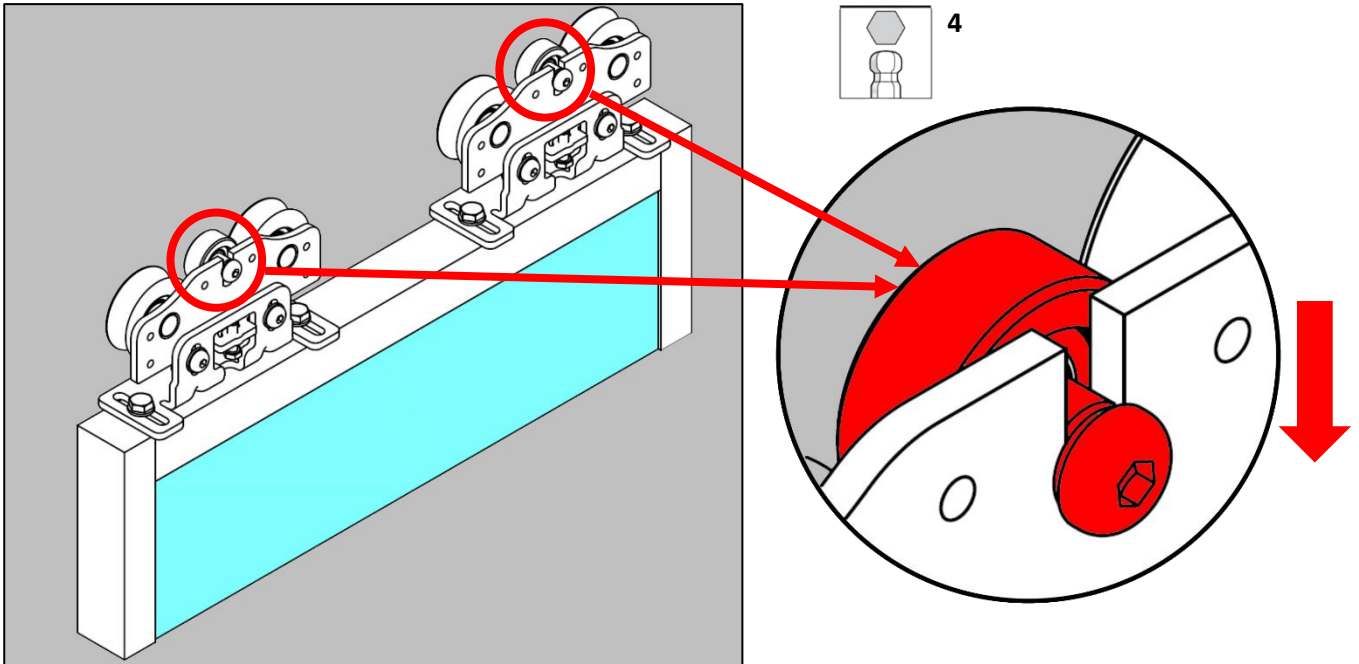

Lift the door and gently position the wheels of the carriages on the sliding guide, taking care not to damage parts with violent impacts.

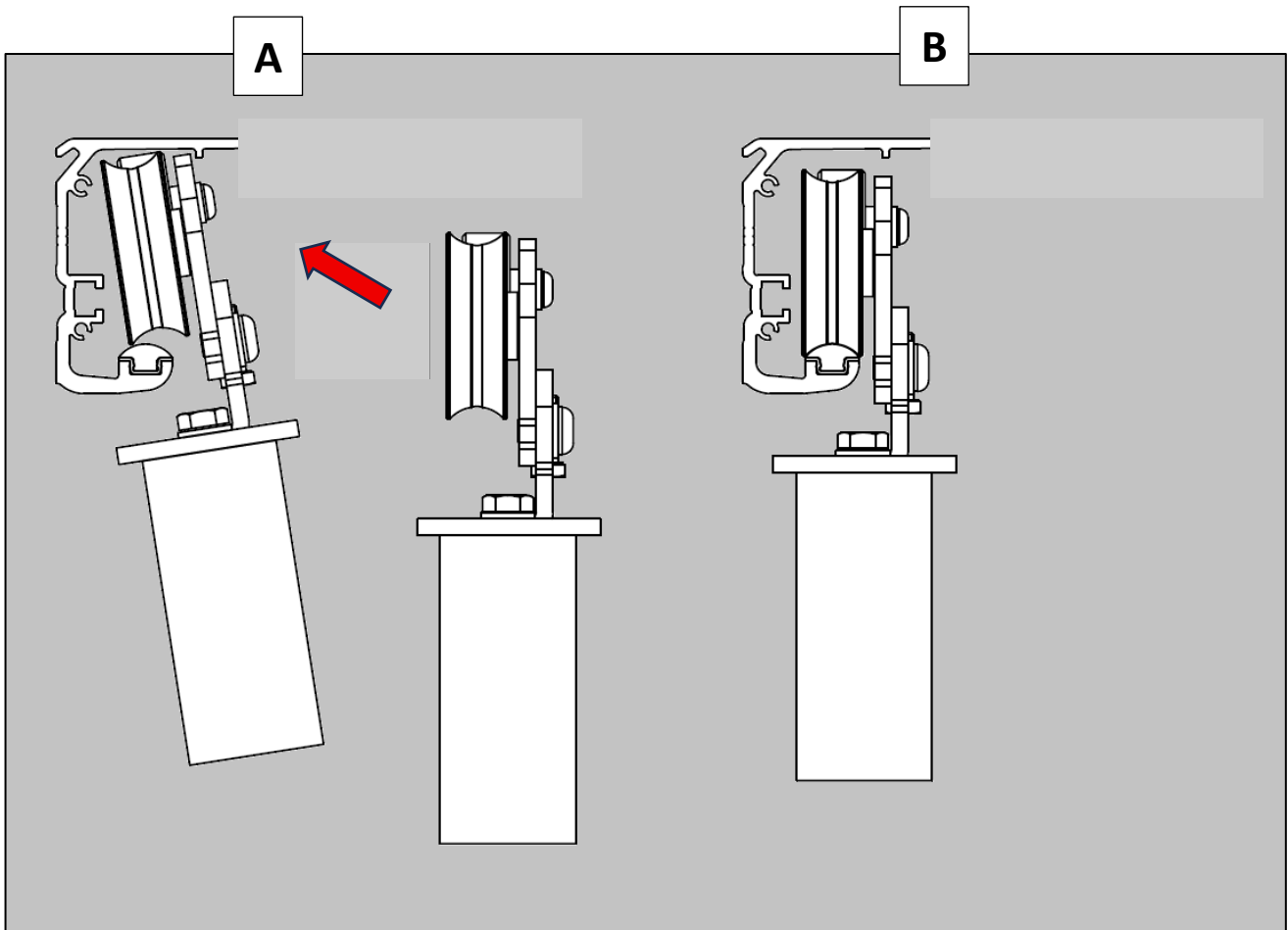

6.2.7.4 DOOR ADJUSTMENT

The wings can be adjusted separately on the two axes (y, z) depending on the installation requirements.

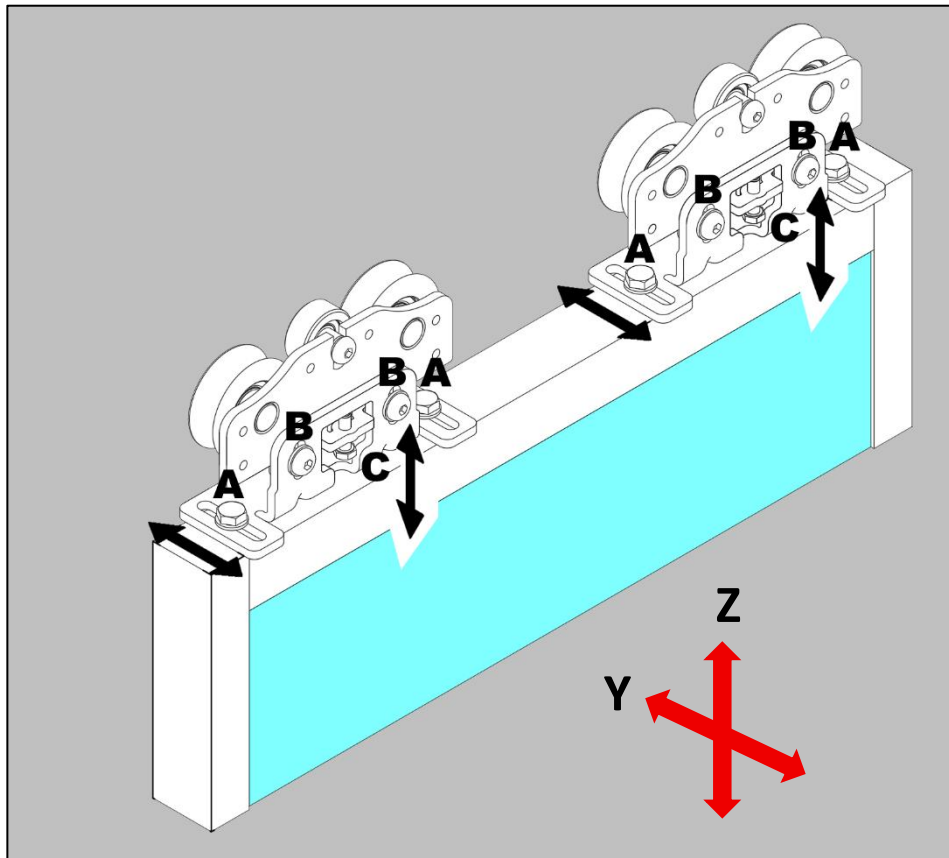

Transverse adjustment (Y): Loosen the fastening screws A and move the wing in the Y direction until it reaches the position necessary for correct operation.

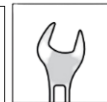
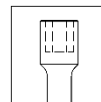
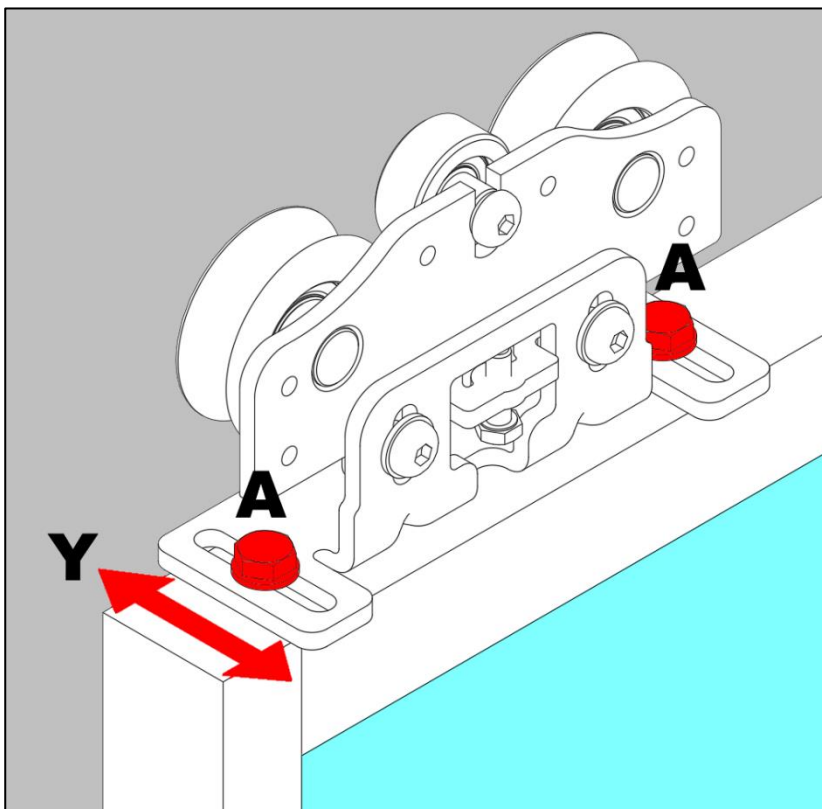

13 ÷ 20.41Nm

Pay attention to the correct alignment of the carriages and their parallelism with respect to the sliding guide. To check the correct alignment, simply make sure that the "E" dimensions measured between the leaf and the carriage coincide for all carriages on both the left and right sides. As further proof of correct alignment, move the doors manually: sliding must take place with minimal effort without any type of impediment or abnormal friction. With the leaves in the correct position, tighten the screws A progressively and alternately until they are completely tightened.

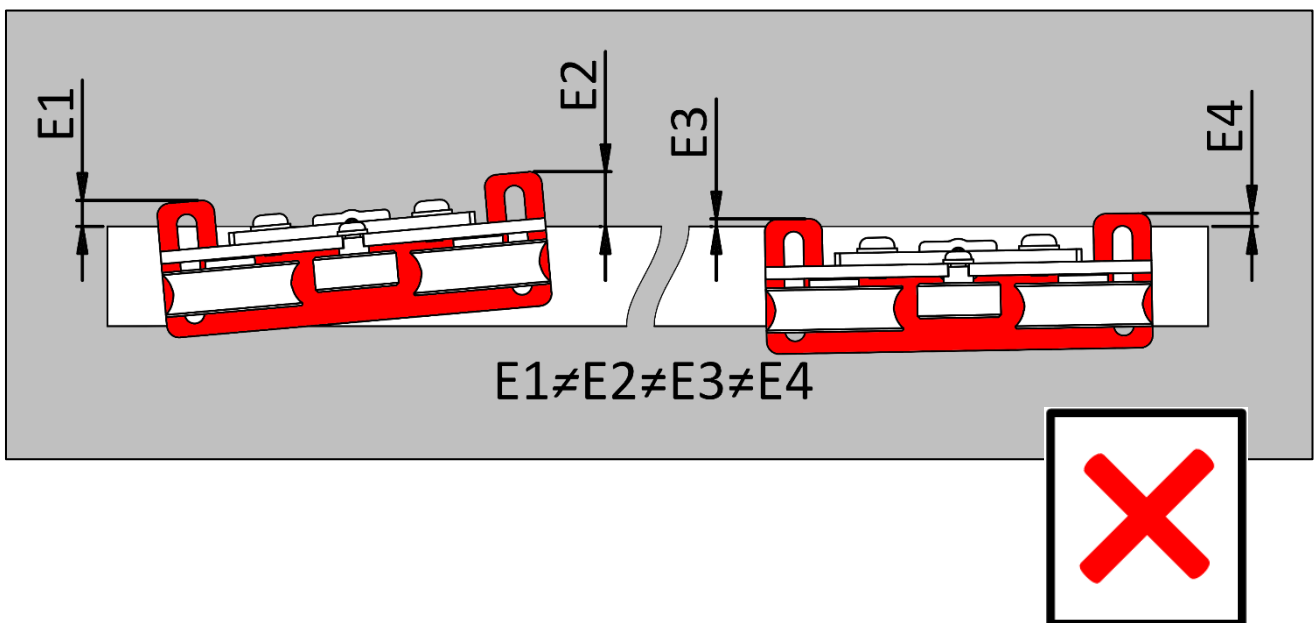
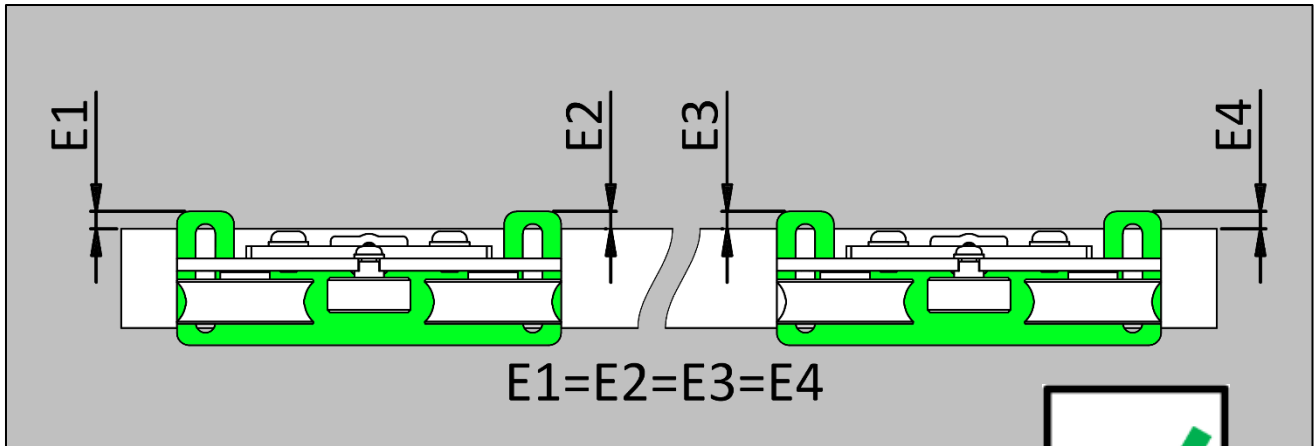

Turning screw A during tightening may cause the carriage to become misaligned. To avoid this inconvenience, tighten the screws progressively and alternately A. Misalignments between the carriages and the sliding guide can cause wear, excessive noise and malfunctions of the operator.

Vertical adjustment (Z): To adjust the door, follow these steps:

1. Loosen the screws B slightly.
Do not completely unscrew the screws B to prevent the door from falling completely.
2. Use the C-level screw to adjust the height of the wings.
3. Tighten the screws G securely, taking particular care not to alter the alignment obtained.

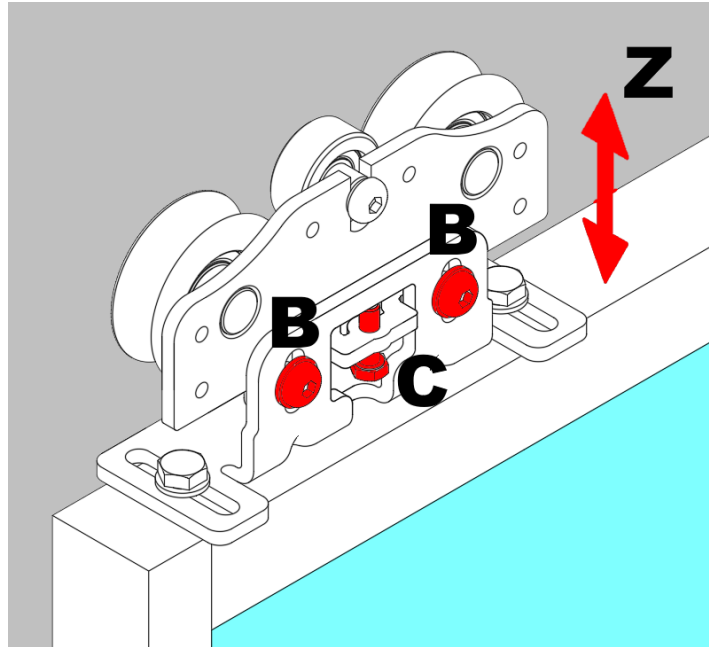
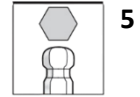

6.2.7.5 COMMISSIONING OF CARRIAGES

Adjust anti-derailment so that the roller is not in contact with the aluminum profile during sliding, maintaining a clearance of 0.5 ± 1 mm. Tighten the screw without altering the chosen setting.

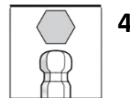
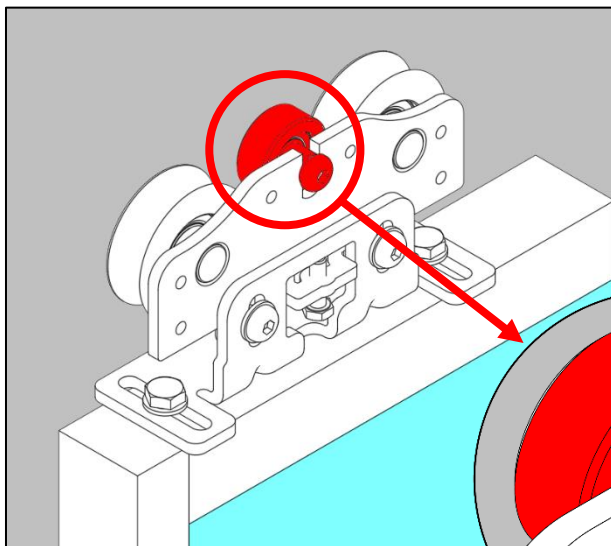

Incorrect adjustment of the derailment device that brings the wheel into contact with the aluminum profile causes excessive wear and noise during operation.

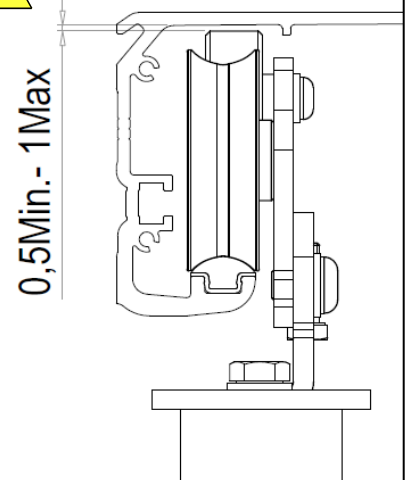

Once the anti-derailment has been adjusted, carefully check that all the screws on the carriages are correctly tightened.



Poorly tightened carriage screws can unscrew, causing parts to come off, the wings fall or the belt to detach, with the possibility that the wing may be out of control when it is in motion and constitute a serious source of danger.

6.2.8. FASTENING OF THE BELT PRESS-BELT SUPPORT FOR THE DOOR/FAST DOOR

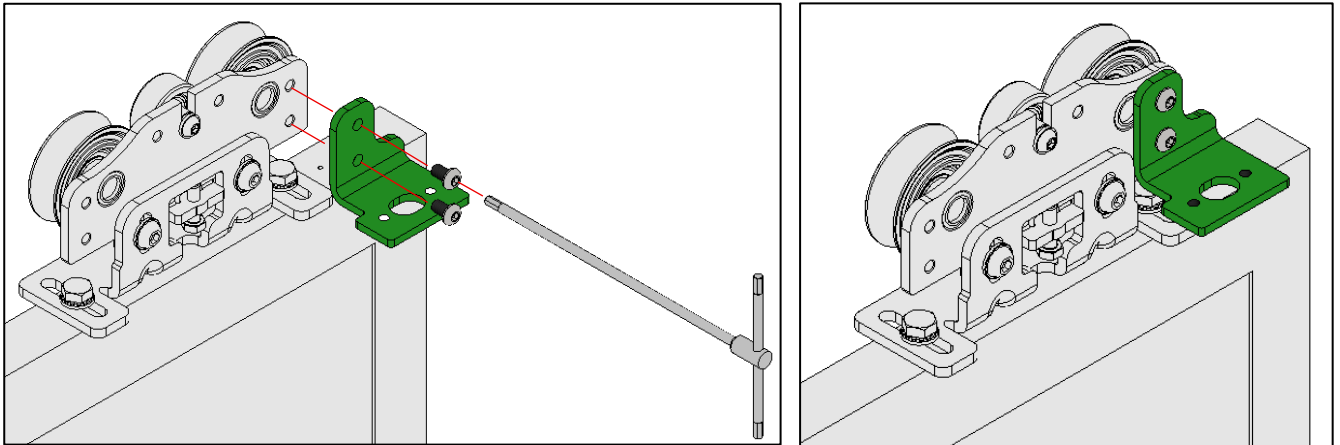

4 – 10,3Nm - Screws TBEI M6x10

ERT80 2 Sliding RIGHT Configuration:
Fast wing opens to the RIGHT

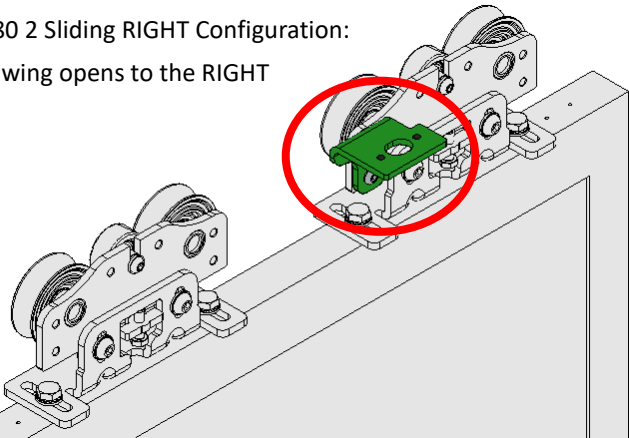

ERT80 2 LEFT sliding configuration:
Slow wing opens to the LEFT

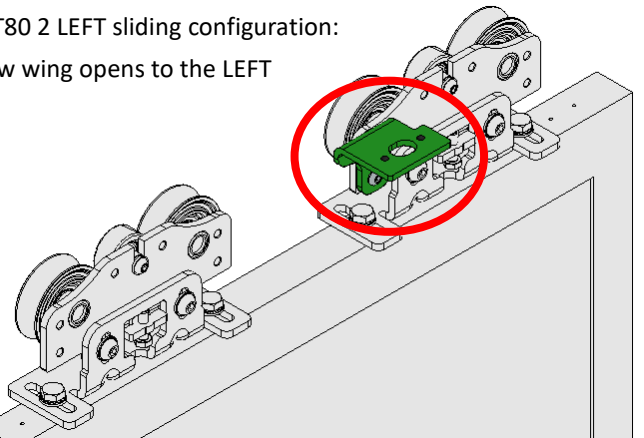

ERT80 4 sliding configuration:
Fast wings

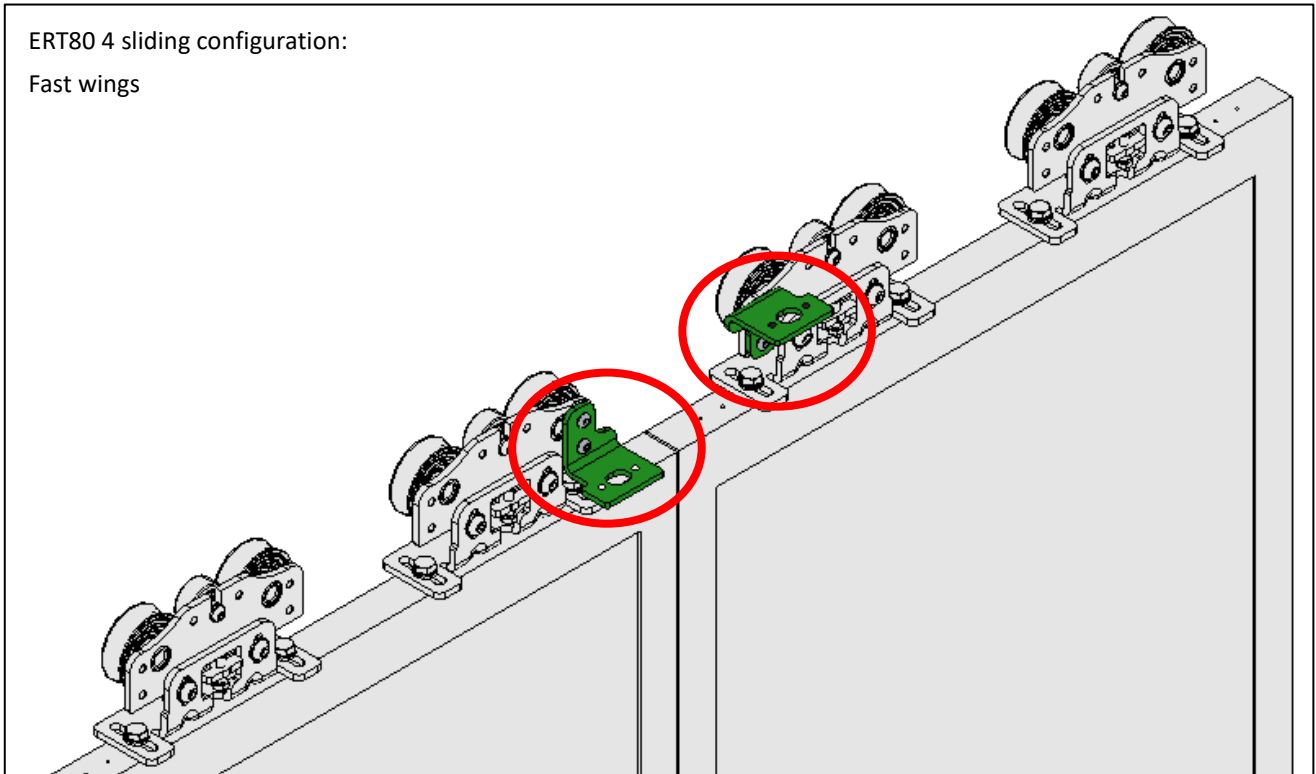

6.2.9. COMPONENT REPOSITIONING AND BELT TENSIONING

After fixing the crossbar and assembling the wings, complete the mechanical operations as follows:

1. Reassemble the components removed when fixing the track, in the **previously marked positions (A)**.
2. Re-tension the transmission belts (B).
3. Fit and attach the belt clamps to the pre-mounted support brackets on the carriages, **following the instructions CAREFULLY (C)**.

A

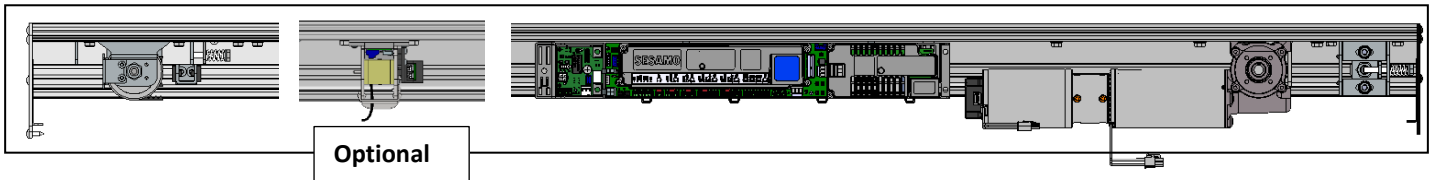

B + C

Before refitting the belt looping, remove the tooth jump guard from the double pulley module (if it has not already been removed).

Assemble the belt of the fast wing first, identified by the passage over the pulleys with a larger diameter

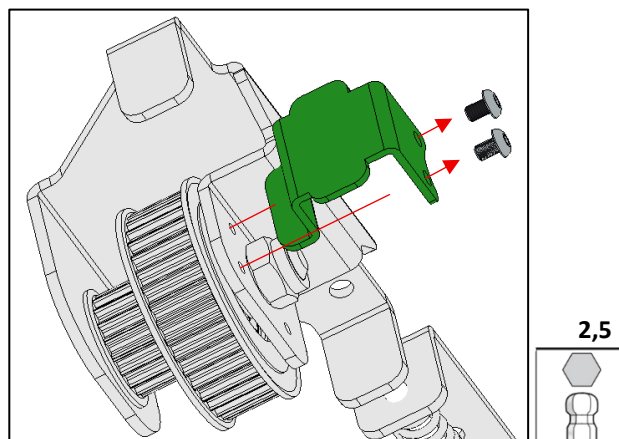

MANDATORY USE OF SESAMO BELTS

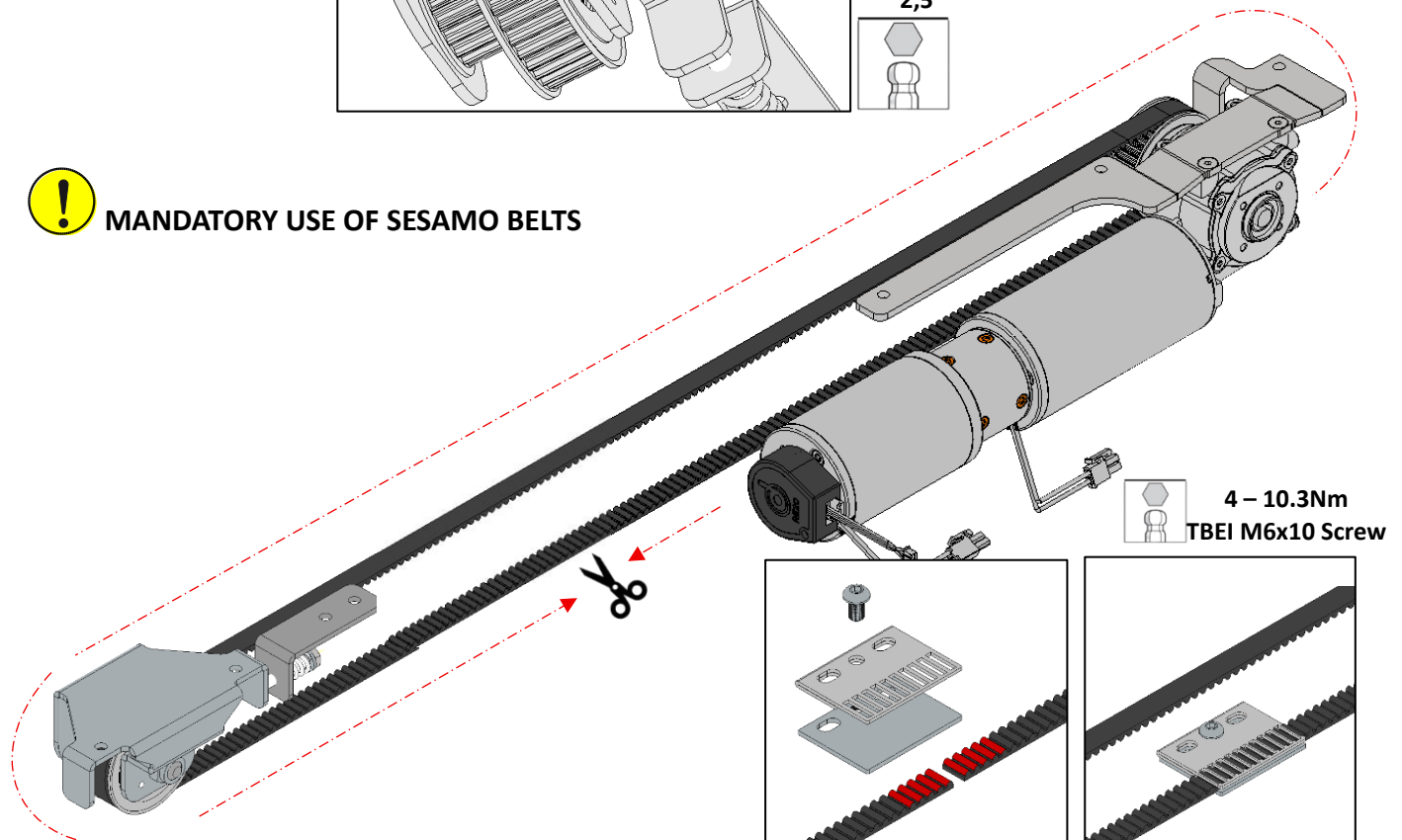

Tension the belt, check that the M6 screws indicated by the letter "A" are slightly unscrewed and **NOT TIGHTENED**.

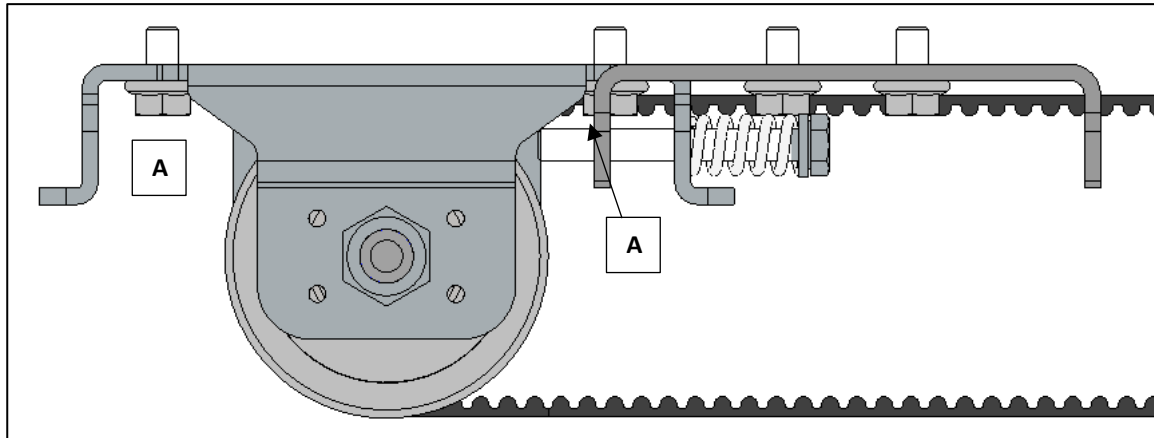

Then tighten the screw indicated with B (VTE M6) in order to compress the spring up and **NO FURTHER!!!** At the level shown in the image.

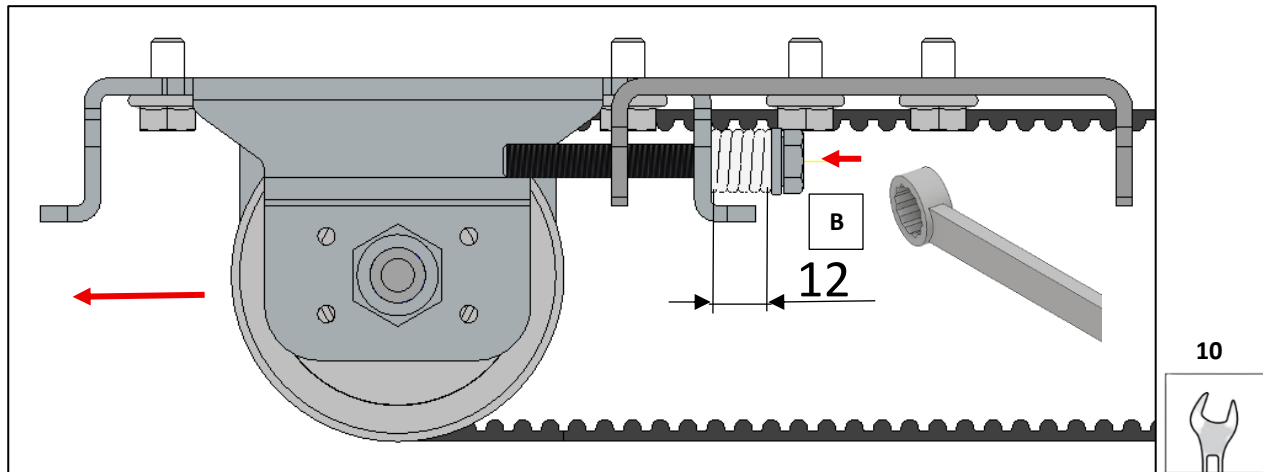

WARNING!!! RESPECT THE INDICATED HEIGHT OF 12MM AS THE SPRING LOAD AND CONSEQUENTLY THE BELT TENSION. A DIFFERENT TENSIONING COULD GENERATE MALFUNCTIONS AND BREAKAGES OF THE OPERATOR COMPONENTS.

Once the correct tension has been set, tighten the screws "A"

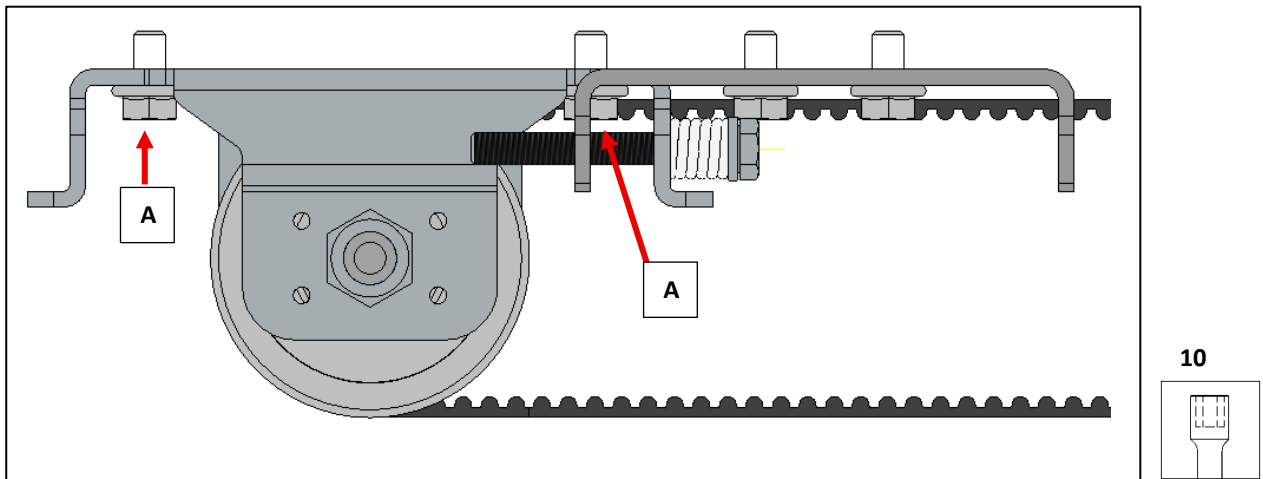

NOTE: Explanatory images only – entrance used for example: ERT80 2 wings opening on the left

VERY IMPORTANT!!!! OBSERVE FOR THE ASSEMBLY OF THE DRIVE BELTS!!!!

Put the doors in closed position and fit the fast-wing belt clamp onto the support bracket pre-mounted on the carriage.

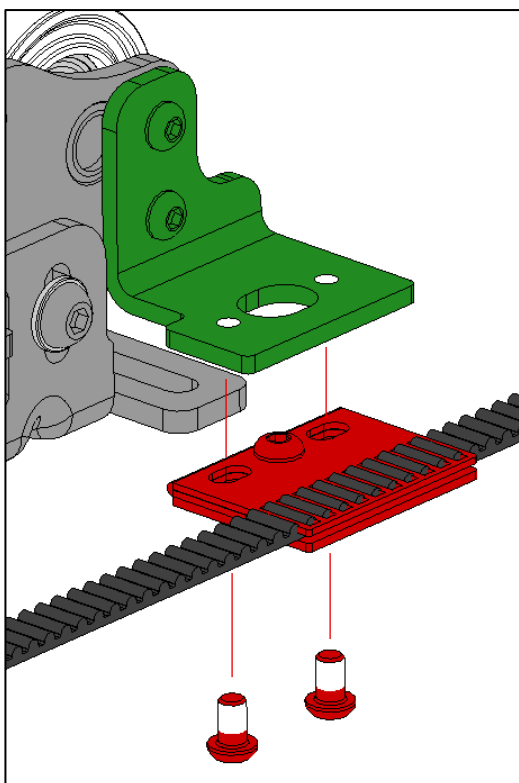
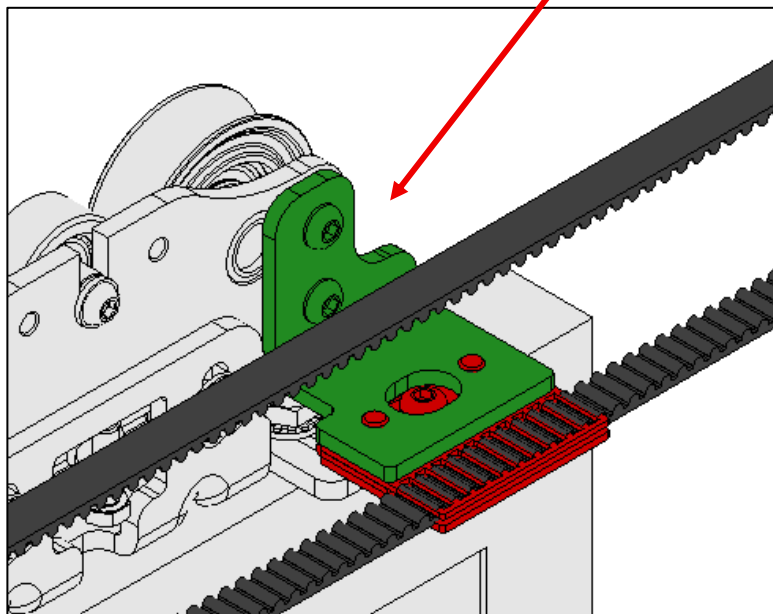
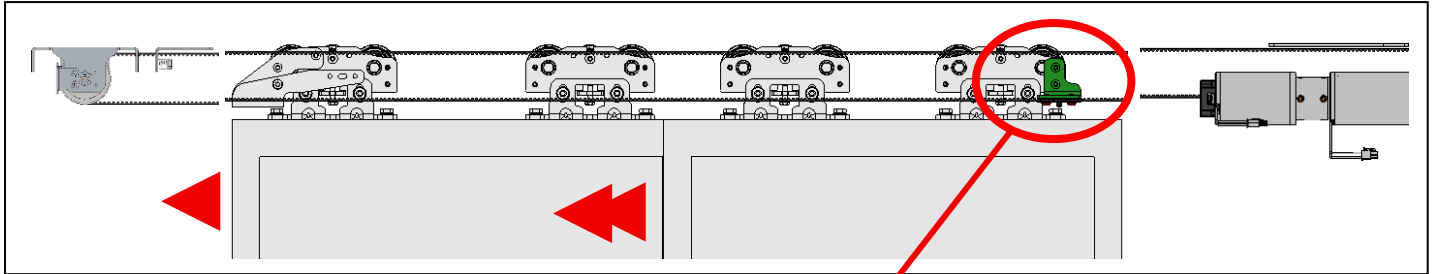

Or if
mounted
backwards



4 – 10.3Nm
TBEI M6x10

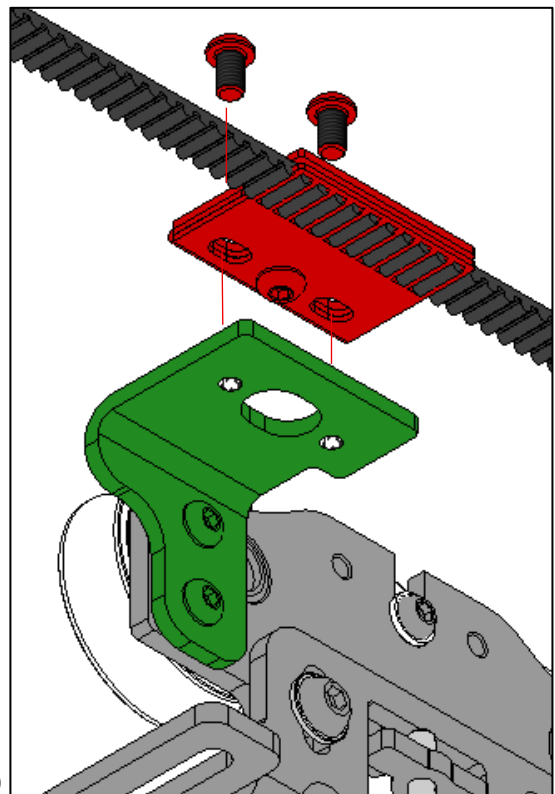

KEEP THE WINGS CLOSED, fit the second belt turn (slow wing) on the pulleys with a smaller diameter.



MANDATORY USE OF SESAMO BELT

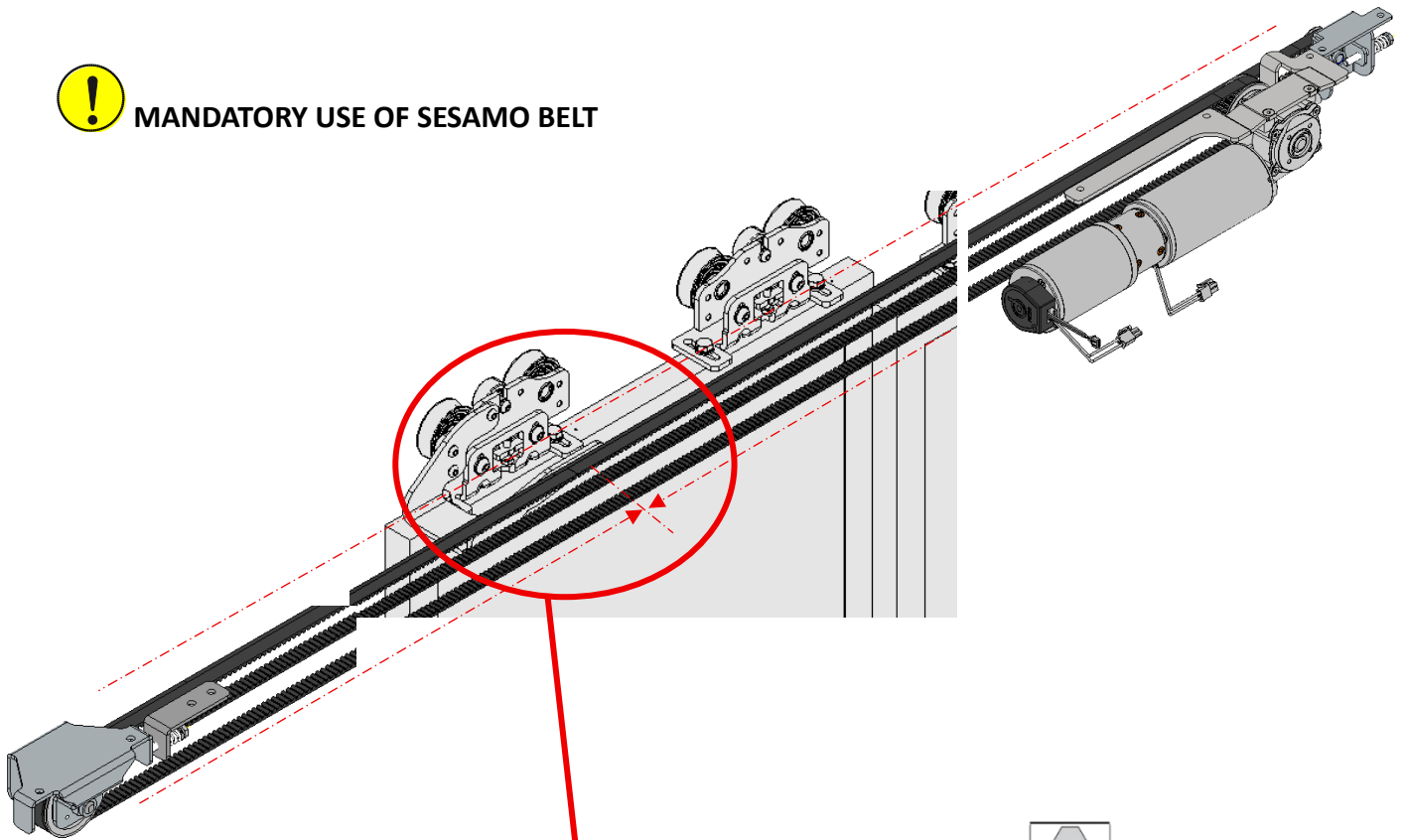

**4 – 10.3Nm
TBEI M6x10 Screw**

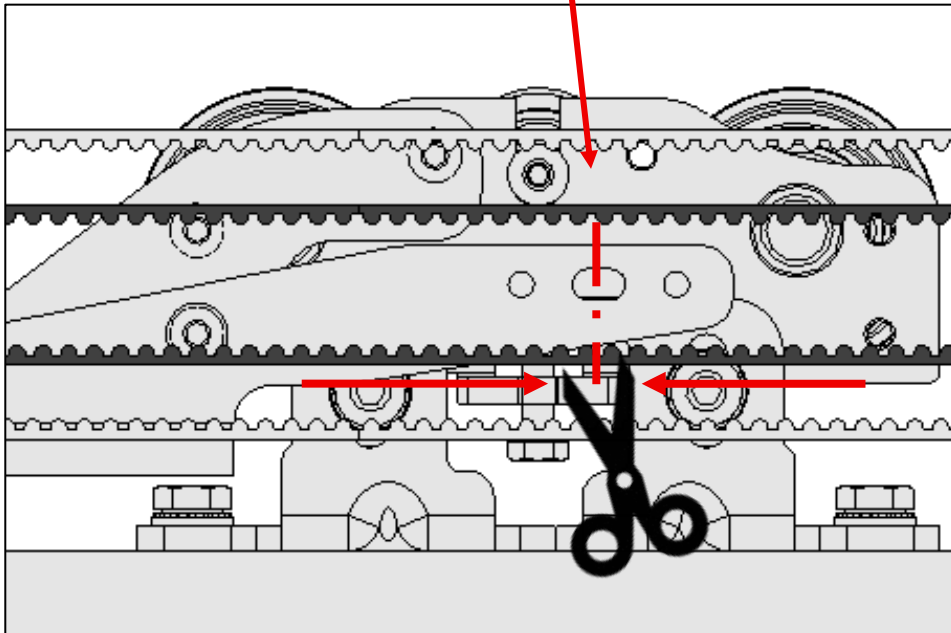
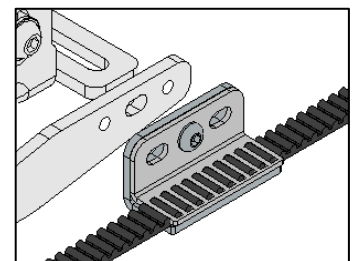
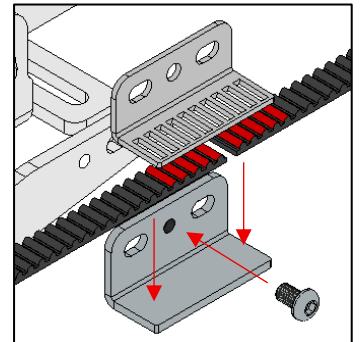

MANDATORY: THE CUTTING OF THE BELT AND THE ASSEMBLY OF THE BELT PRESS MUST BE CARRIED OUT ALIGNED WITH THE AXIS OF THE FIXING HOLE OF THE BELT PRESS ITSELF.



Tension the second belt, check that the M6 nuts indicated by the letter "A" are slightly unscrewed and NOT TIGHTENED.

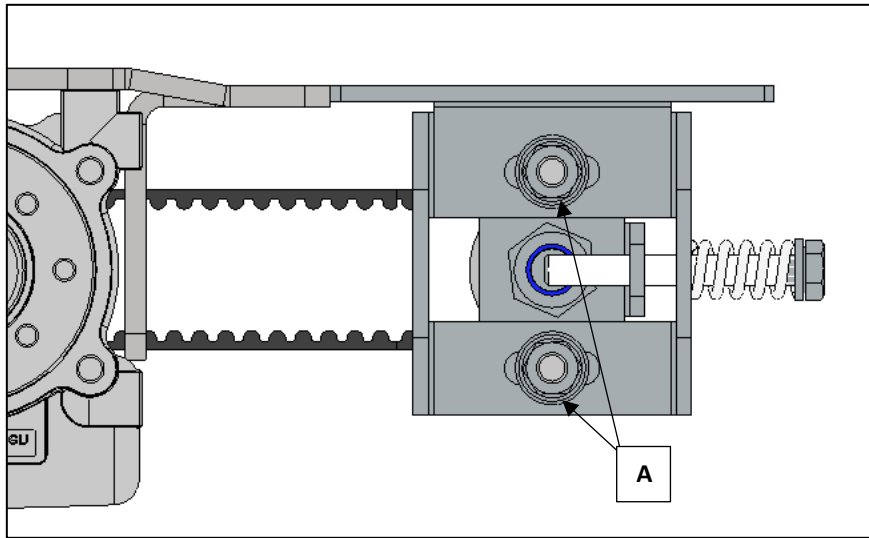

Then tighten the screw indicated with B (VTE M6) in order to compress the spring up and **NO FURTHER!!!** At the level shown in the image.

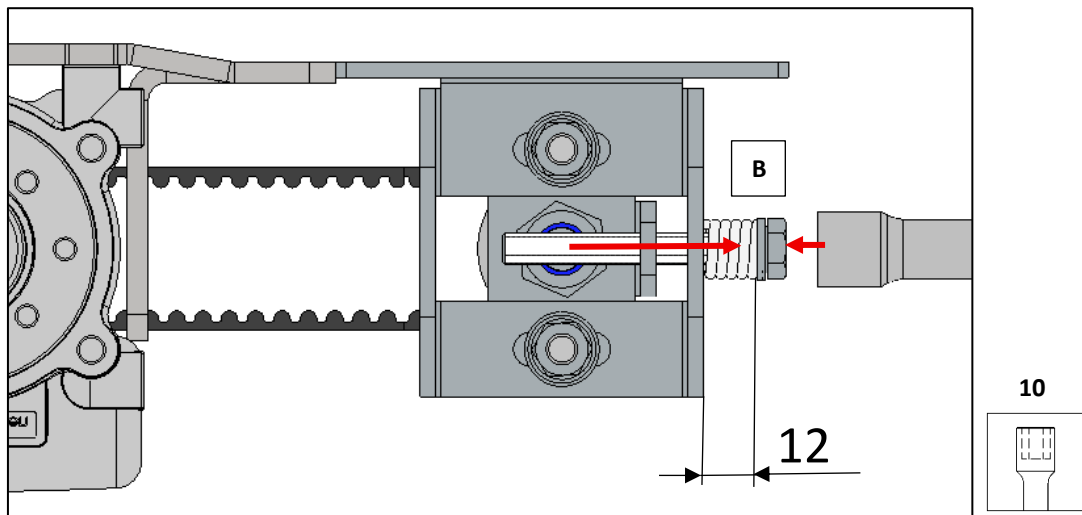

WARNING!!! RESPECT THE INDICATED HEIGHT OF 12MM AS THE SPRING LOAD AND CONSEQUENTLY THE BELT TENSION. A DIFFERENT TENSIONING COULD GENERATE MALFUNCTIONS AND BREAKAGES OF THE OPERATOR COMPONENTS.

Once the correct tension has been set, tighten the screws "A"

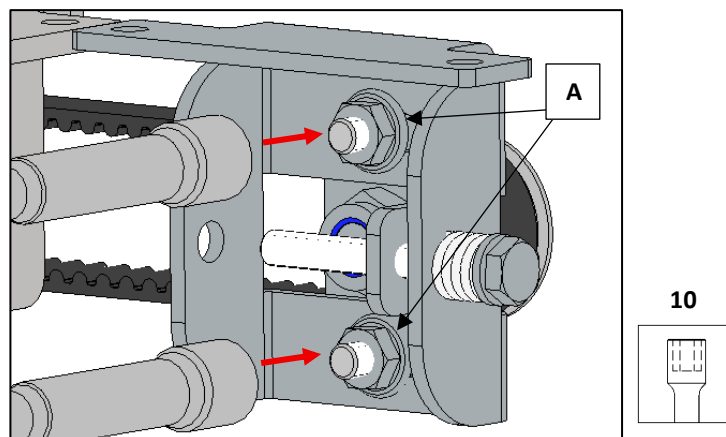

NOTE: Explanatory images only – entrance used for example: ERT80 2 wings opening on the left

VERY IMPORTANT!!! TO BE OBSERVED WHEN INSTALLING THE SLOW WING BELT PRESS!!!!

With the wings already closed previously, fit the wing belt press onto its support bracket.

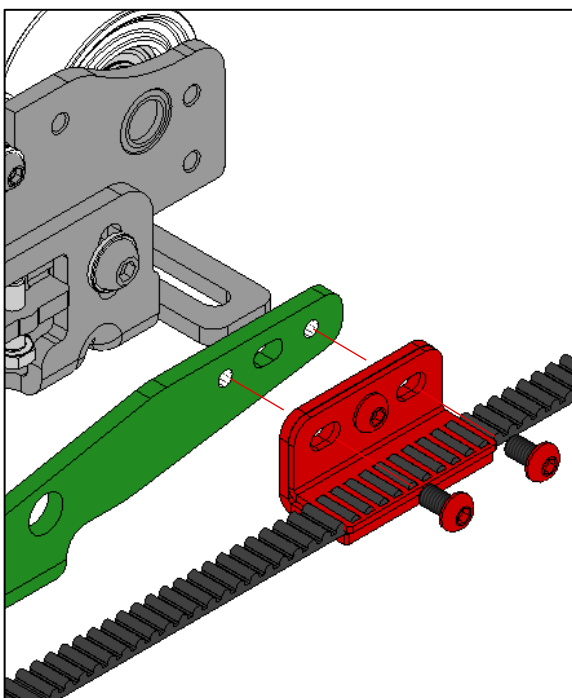
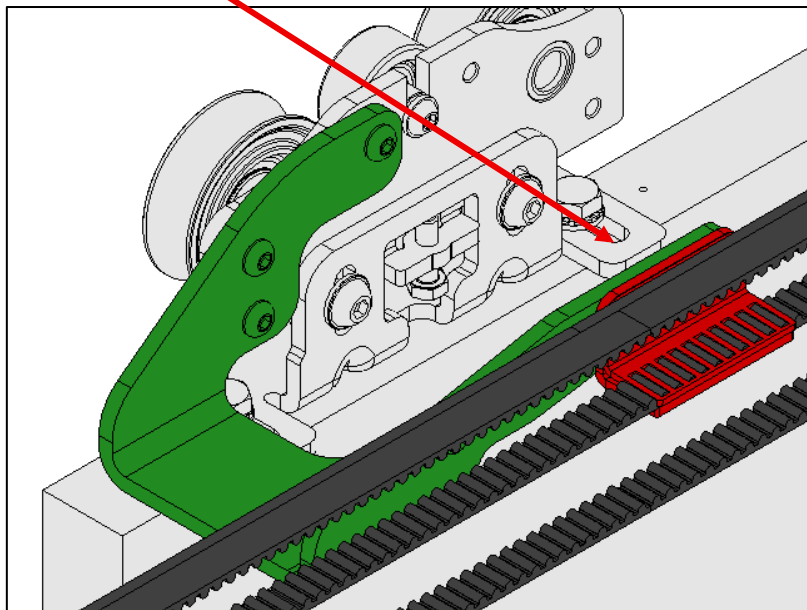
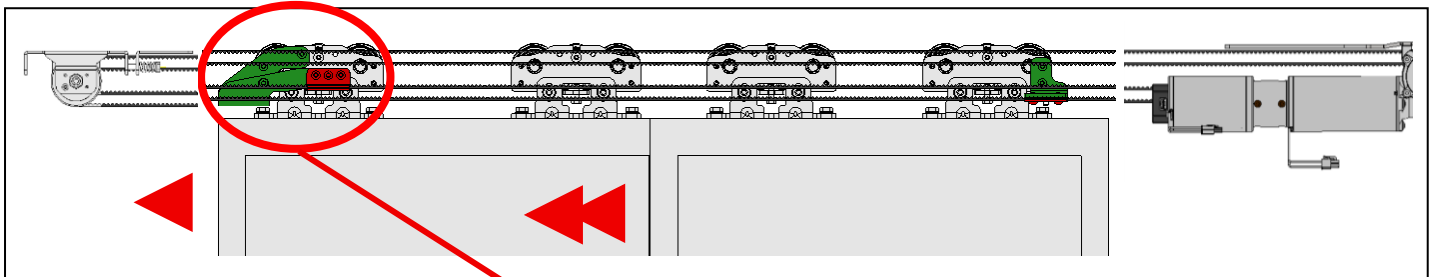

Or if
mounted
backwards



4 – 10.3Nm
TBEI M6x10

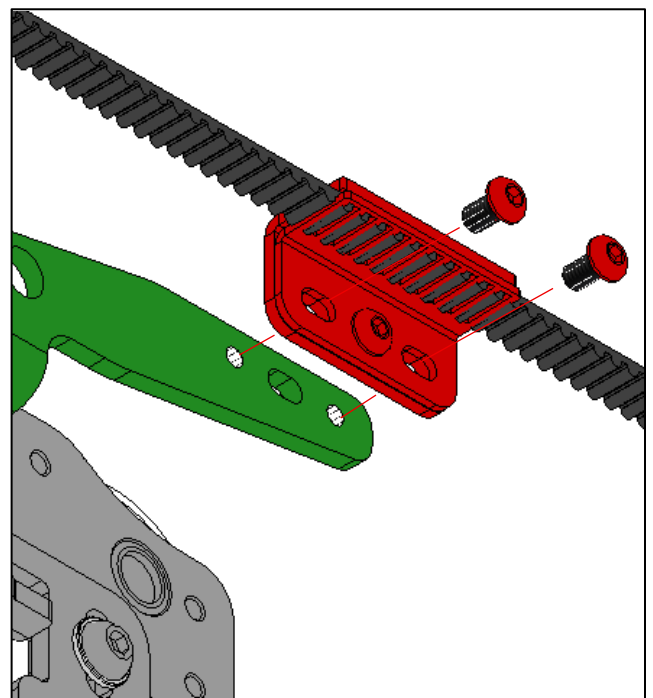

6.2.10. FINAL ASSEMBLIES

1. Refit the tooth jump guard previously removed from the double pulley module

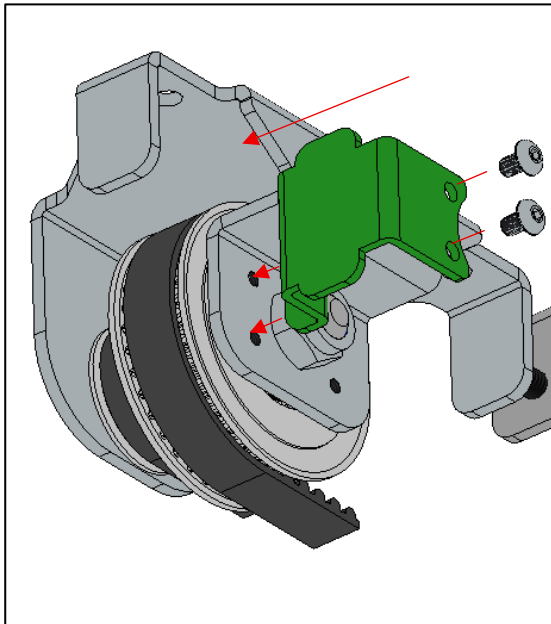

2,5

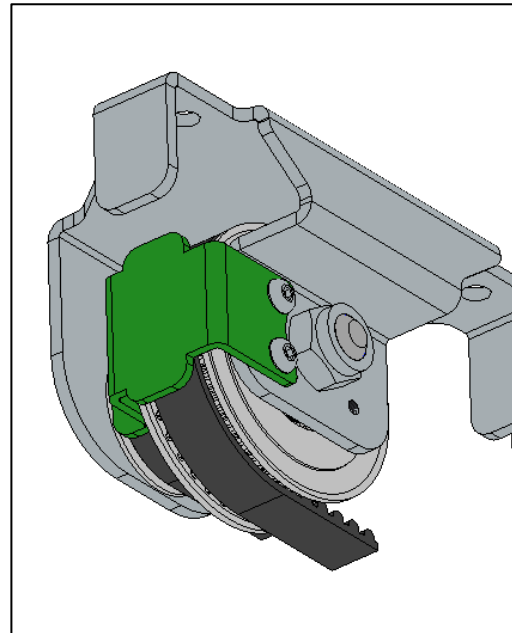

2,5

2. Close the cover by repeating the steps on page 16 but in reverse.

7. FINAL CHECKS MECHANICAL ASSEMBLY

Before starting the operator, check and perform the following operations:

- Carefully remove any dust or chip residues from the runway and carriage wheels
- check the correct tightening of the screws of all the components of the operator
- check the correct belt tension
- check that the wiring cables are fixed and there are no ones running near the sliding area of the carriages or the belt
- Check that the limit switches are correctly positioned and that the belt clamps do not come in contact with the belt pulleys
- If necessary, spread a light film of common bearing grease on the sliding rails and on the drive belt



The sliding rails and the transmission belt can work without lubrication without wearing problems. However, light lubrication prevents noise from occurring if there is no perfect alignment between the parts.



For correct operation, it is very important that there are no mechanical impediments or friction that hinder movement throughout the sliding area of the doors: if in doubt, perform a manual handling test with a dynamometer to identify any points with excessive friction and eliminate them.

7.1 CONNECTIONS AND COMMISSIONING



For mains connections, all accessories and commissioning, use the POWERCORE manual.

8. USER MANUAL

Recipient and use of the manual:

These instructions are intended for the manager or user of a SESAMO POWERCORE SERIES automatic door system: in order to obtain the best performance from the operator, Sesamo recommends that you read and carefully follow the instructions for use in this manual. This device is designed for the operator of sliding doors. Any other use will be considered contrary to the intended use by the manufacturer who, therefore, cannot be held liable. Do not tamper with or alter the internal equipment of the operator system and all the safety devices provided in the control unit for any reason. The manufacturer declines all responsibility if internal parts of the operator are altered or tampered with or safety devices are used in the system other than those indicated by the manufacturer itself. Description of operation: the operator is of the type required by the regulations for installations on escape routes. It is equipped with an energy storage device (NiMh batteries) that is recharged when turned on, this operation can take 15/30 seconds. Upon completion of this operation, the operator performs two complete opening and closing cycles to check the functionality of the main and auxiliary control boards. At the end, it is positioned in the logic previously set on the Digidoor operating logic selector. At this point, the operator is ready to operate in ways that depend on the type of peripherals and accessories installed and the logic selected by selector; it will perform automatic openings and closings of the window so as to allow the passage of people in complete safety and continuously. The opening of the leaves can be controlled by detection sensors, by the advanced or basic selector and by buttons for manual control; The opening cycle can be followed by a stop or automatic reclosing depending on the chosen logic (see description of selector logics). The stop of the leaves in the open position facilitates the passage of people according to the customer's needs, the dwell time can be adjusted at the time of installation. The doors close automatically at the end of the parking time, with a slower speed than opening. The safety of the operator is entrusted to the active safety sensors that detect the presence of any obstacles in the sliding area and possibly prevent the reclosing of the leaves. As an additional safety, the operator is equipped with a sophisticated microprocessor device that limits the pushing force of the leaves in the event of danger, so as not to be a source of danger for people in transit. For safety reasons, the operator is designed so that it is always possible, even in the absence of mains and battery, to move the leaves manually after unlocking the door locking device if installed with the appropriate key.

Logics – Logic selection:

To select the logic described, follow the explanations in the following paragraphs. The meaning of the logics is as follows:

- **Automatic:** The door works in entry and exit mode.
- **Exit Only:** The door operates in exit-only mode. Any electric lock device, if installed, blocks the movement of the wings in the closed position.
- **Stop open:** the doors remain permanently open.
- **Manual:** the automatic opening controls are deactivated and the door can be moved manually.
- **Exit Only Partial Open:** The door operates in exit only mode with reduced opening.
- **Automatic partial opening :** the door operates in entry and exit mode with reduced opening.
- **Partial Opening in Stop or Closed position:** The door operates in entry and exit mode with reduced opening.
- **Settings menu:** for calendar setting or adjustments. See Digidor manual
- **Diagnostics menu:** to view the input diagnostics. See Digidor manual







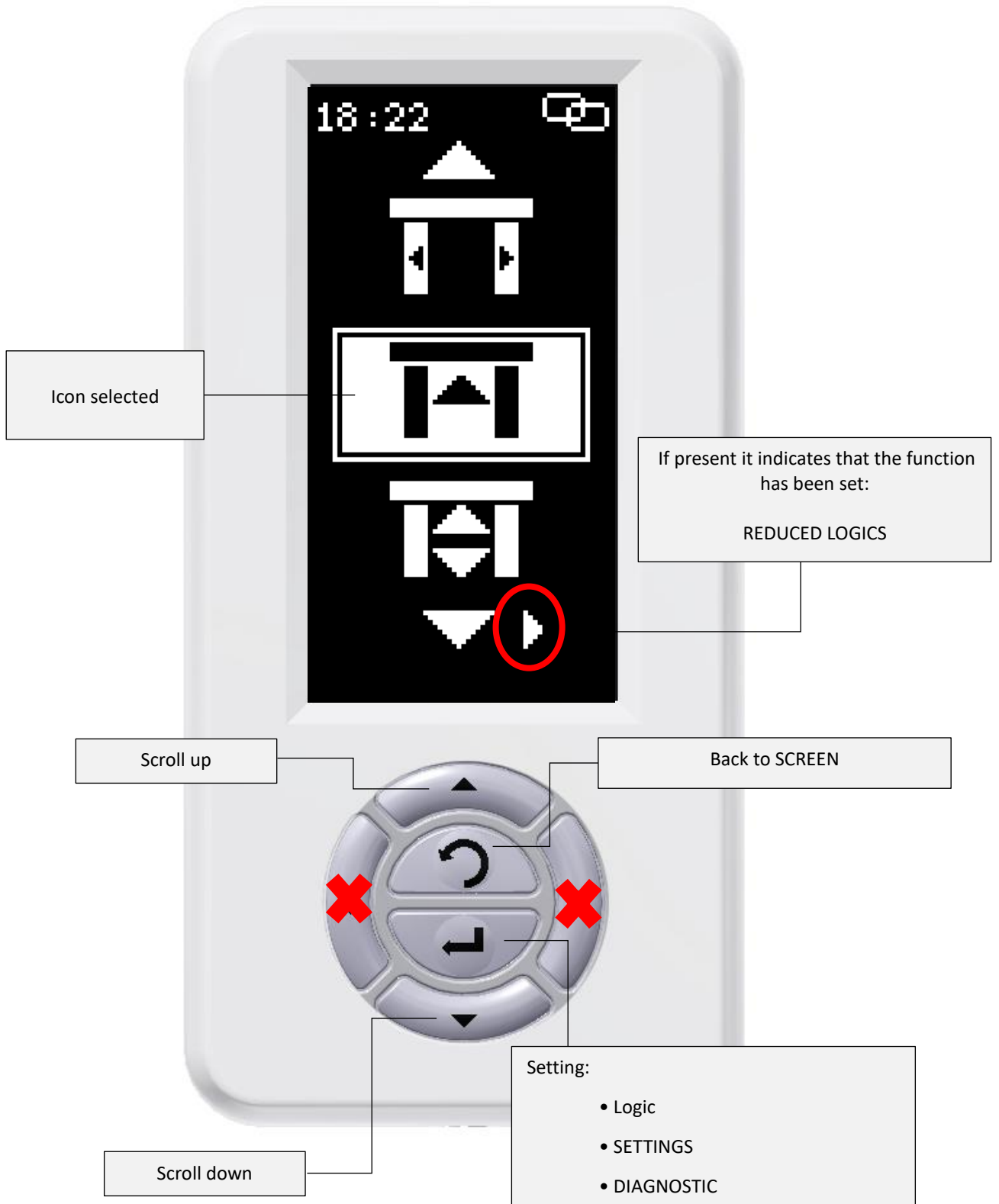



For specific functions other than basic functions, consult the selector manual.

Digidor:

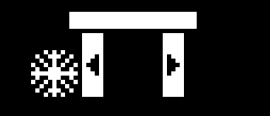

List of menu icons:

Sliding doors:

ICONS	DESCRIPTION
	Stop open
	Exit only
	Automatic
	Partial Opening Exit Only
	Automatic partial opening
	Partial Opening in Stop or Open position
	Manual
	Menu SETTINGS
	Menu DIAGNOSTIC

Logic selection: to select the logics described below, press the scroll down or scroll up several times until the icon corresponding to the desired logic is highlighted. Confirm with the enter key.

Logic Description:

- **Stop open:** the doors remain permanently open
- **Output Only:** The port operates in exit-only mode. The motor generates a closing thrust when the doors are opened manually.
- **Automatic:** The door works in entry and exit mode
- **Exit Only Partial Open:** The door operates in exit only mode with reduced opening.



Caution: The passageway may not be sufficient for the emergency exit. Check before activating. This control can only be activated via TAG. The motor generates a closing thrust when the doors are opened manually.

- **Automatic partial opening :** the door operates in entry and exit mode with reduced opening.



Caution: The passageway may not be sufficient for the emergency exit. Check before activating. This control can only be activated via TAG. The motor generates a closing thrust when the doors are opened manually.

- **Partial Open Stop Open:** The door operates in entry and exit mode with reduced opening.



Caution: The passageway may not be sufficient for the emergency exit. Check before activating. This control can only be activated via TAG. The motor generates a closing thrust when the doors are opened manually.

- **Manual:** the automatic opening controls are deactivated and the door can be moved manually.



Please note: With the manual function, the door is not enabled for escape mode. This command can only be activated via TAG. Use only in the presence of the person responsible for managing the escape route.

- **Settings menu:** for calendar setting or adjustments. See Digidoor manual
- **Diagnostic menu:** see Digidoor manual



- **Night lock:** can only be activated via TAG. The escape route function is deactivated. Any electric lock device, if installed, blocks the movement of the leaves in the closed position. The opening in the absence of electricity is deactivated. When reactivated following the night lock, the door performs two opening and closing cycles (main card verification – secondary card verification).

Activating and deactivating night lock:

I bring TAG closer to



Tag stored with a function – deactivate function:



Manual Unlocking:

For safety reasons, any Electric lock device of the leaves is equipped with a manual release control. It is provided in the two versions explained below.

Manual release (already standard on all Electric locks):

The unlocking is obtained by proceeding as follows:

1. Insert a screwdriver into the release hole on the cover (the hole is identified by a special sticker.)
2. Push the screwdriver until it reaches the internal lever pre-installed on the lock.
3. Operate the lever by exerting upward pressure
4. At the same time, open the doors manually.

Reference Image:

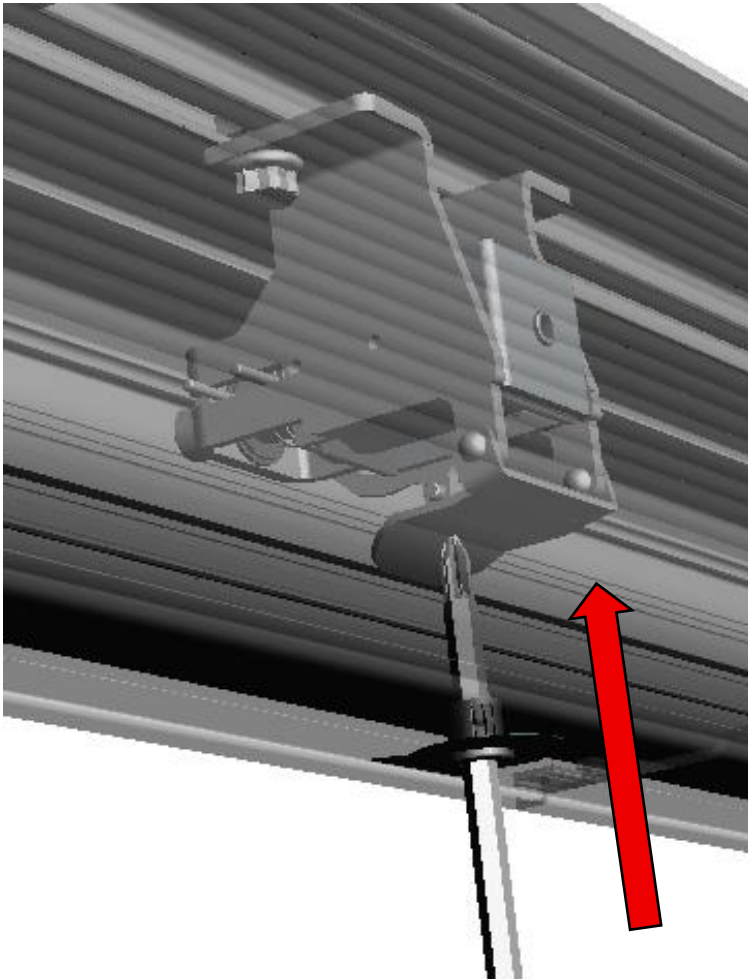

Lever release:

The release is obtained by acting on the special lever handle installed near the system or on one of the heads of the operator, the operation on the release handle allows the leaves to be moved manually. By repositioning the handle in the initial position, the electric lock returns to lock the doors.

The release mechanism should be checked periodically to prevent looseness, dirt, wear, corrosion, or other unforeseen causes from preventing it from working properly.

Electronic key/key selector:

Through this accessory, together with the electric lock device, it is possible to close the doors from outside the room, regardless of the logic selected on the basic or advanced selector. Any lack of power after this closing will not open the doors

Each time the electronic key is inserted, the operator switches from a normal operating condition to a locking condition and vice versa. During the transition from the locked to normal operating condition, the leaves perform a complete opening and closing cycle so as to allow a person to enter.

Cleaning:

Subject	Mode
Painted surfaces	Cleaning with soap and water
Anodized surfaces	Cleaning with non-alkaline soap and water (pH 5.5/7)
Selectors	Cleaning with a damp cloth
Sensors	Cleaning with a damp cloth

Maintenance intervals:**Maintenance:**

The maintenance interval is determined according to the intensity of use of the operator and the conditions of use. Servicing should only be performed by a qualified technician. Each maintenance must be noted in a log book. See application example contained in Annex A of this manual.

In traffic-intensive installations (entrances to airports, supermarkets, shopping centers, refreshment areas in motorway rest areas, etc. greater than 200 cycles/day) or operating in particularly harsh conditions (exposure to corrosive agents, proximity to the sea, very windy areas, doors subject to frequent collisions with moving objects such as supermarket carriages, etc.) Scheduled maintenance should be carried out at **six-monthly intervals** by a specialized technician.

In low-traffic facilities (small businesses, private offices, homes, operating theatres, etc. up to a maximum of 200 cycles/day) it is advisable to carry out scheduled maintenance at annual intervals by a specialized technician.

9. MAINTENANCE MANUAL

During a scheduled maintenance intervention, carried out by a specialized technician, it is necessary to carefully carry out the following checks and procedures:

- ❑ Cut off the mains power supply using the two-pole switch upstream of the operator. If the operator is equipped with batteries, the doors may open and remain open.
- ❑ Make sure that the two-pole switch installed upstream of the operator system intended to disconnect the power supply is visible from the operating point of the door on which you are working. If it is not, it is necessary to implement a safeguard system that ensures that voltage is not reactivated unintentionally
- ❑ Open the operator by disassembling the cover.
- ❑ Disconnect the batteries
- ❑ Check the tightness of the screws of the carriages and the components installed inside the box.
- ❑ Check the wiring connections between the accessories, sensors and the control unit.
- ❑ Clean the sliding rail with a cloth (No cleaning products) and check its integrity.
- ❑ Check the smoothness of the door, its general condition (evaluate any out-of-square caused by impacts) and above all that there is a minimum space of 5 mm between the floor and the wing. in order to ensure correct sliding even in the event of strong thermal expansion of the door panel.
- ❑ Clean the wheels of the carriages and check them for wear, replace them if necessary.
- ❑ If necessary, grease the sliding rail with a thin layer of bearing grease.
- ❑ Check the state of wear of the belt and grease it if necessary.
- ❑ Check the state of wear of limit switches, and replace and adjust them if necessary.
- ❑ Check the floor guide for wear and proper functionality and, if necessary, grease or replace it.
- ❑ Check the correct operation of the electric lock, manual release and manual reset. If necessary, lubricate the release cable.
- ❑ Reconnect the batteries, close the operator cover, reconnect to the mains power supply
- ❑ Check the safety sensors (functionality and adjustment).
- ❑ Check the opening sensors (functionality and adjustment).
- ❑ Check the movement of the wings when braking and approaching.
- ❑ Check that the operating logic has been correctly selected.

COMPONENT REPLACEMENT

For the ER redundant version, the following components must be replaced in advance depending on the number of opening/closing cycles that can be detected on the main board and/or by means of a Digidor selector.

- ❑ Motor 1,000,000 cycles
- ❑ Belt replacement 1,000,000 cycles
- ❑ Carriage wheels 1,000,000 cycles

C187800_00_MAN_ERT80_ENG_03_03_26



SESAMO srl
Str. Gabannone, 8/10
15030 Terruggia (AL) Italy
Tel: +39 0142 403223
Fax: +39 0142 403256
www.sesamo.eu
e-mail: info@sesamo.eu

Annex A

MAINTENANCE LOG

Description of the intervention

Installation Start-up Adjustments Maintenance Repair Changes

Date: _____

Technical: _____

Client: _____

Description of the intervention

Installation Start-up Adjustments Maintenance Repair Changes

Date: _____

Technical: _____

Client: _____

Description of the intervention

Installation Start-up Adjustments Maintenance Repair Changes

Date: _____

Technical: _____

Client: _____

Description of the intervention

Installation Start-up Adjustments Maintenance Repair Changes

Date: _____

Technical: _____

Client: _____

Annex B

EC Declaration of Conformity

EC Conformity Declaration

Nome del fabbricante / Company name	Sesamo S.r.l.
Indirizzo postale / Postal address:	Strada Gabannone, 8/10
CAP e Città / Postcode and City:	I – 15030 - Terruggia (AL)
Telefono / Telephone :	+39 0142 403223
E-mail address:	info@sesamo.eu
Sito web / Web site	www.sesamo.eu

This Declaration of Conformity² is issued under the sole responsibility of the manufacturer and refers to the following equipment:

This Declaration of Conformity is issued under the sole responsibility of the manufacturer and it belongs to the following equipment:

Dispositivo e modello / Equipment and model	Sliding door - 2 or 4 - leaves suitable for installation on escape routes POWERCORE model
Product Type :	ERT80 ³
Serial number:	To be detected by the identification plate of the car

Subject of the declaration:

Object of the declaration :

Pedestrian doors mod. POWERCORE Type ERT80

Pedestrian doors mod. POWERCORE tipo ERT80



The subject matter of this Declaration of Conformity is in accordance with the applicable Essential Health and Safety Requirements [RESS] which are contained in Annex I of the following European Union legislation /

The subject of this Declaration of Conformity is compliant with the applicable Essential Health and Safety Requirements [EHSR] included in the Annex I of the relevant legislation of European Union :

² This declaration of conformity is valid only if the products to which it refers are installed and used following the use and maintenance instructions delivered by Sesamo Srl as manufacturer of the equipment

³ Door complete with redundant drive, frame and leaf(s) to form the complete sliding pass door

Directive 2006/42/EC (Machinery Directive)

2006/42/EC Directive (Machinery directive)

Reference to the applicable parts of the main relevant harmonised standards /

The applicable requirements of the following harmonised standards and technical specifications have been used:

Titolo / Title :	Data / Date
EN ISO 12100 Safety of machinery – General design principles - Risk assessment and risk reduction	2010
EN 16005 Motorized Pedestrian Doors Safety in use – Requirements and test methods	2012 +A1:2015
EN 60335-1 Household and similar electrical appliances. Safety General requirements	2019
EN 60335-2-103 Household and similar electrical appliances. Safety Particular requirements for drives for gates, doors and windows	2015
EN 61000-6-2 Electromagnetic compatibility (EMC) Part 6-2: Generic standards - Immunity standard for industrial environments	2016
EN 61000-6-3 Electromagnetic compatibility (EMC) Part 6-3: Generic standards - Emission standard for equipment in residential environments	2020
EN 13849-1 Safety of machinery – Safety-related parts of control systems - Part 1: General principles for design	2015
EN 13849-2 Safety of machinery – Safety-related parts of control systems - Part 2: Vacoveration	2012

Other technical specifications used /

Other technical specification applied:

Titolo / Title :	Data / Date
==	==
==	==

Notified body (if applicable) /

Notified body (where applicable):

Not applicable

Not Applicable

Additional information : None

Additional information : None

In response to a reasoned request from the competent national authorities, the manufacturer undertakes to make available all relevant information - on the machinery - without prejudice to his intellectual property rights.



In response to a reasoned request by the national competent authorities, the manufacturer of the machinery agrees to make all the relevant information - on the machinery - available unless of his intellectual property rights

The machinery covered by this declaration also complies with the provisions of the following European directives

The machinery subject of this declaration is also conformed with the provisions of the following european directive

Directive 2014/30/EU (electromagnetic compatibility)

2014/30/EU Directive (Electromagnetic compatibility)

Name and address of the person authorised to prepare the technical file <i>Name and address of the person authorised to compile the technical file,</i>	
	<p style="text-align: center;">SESAMO S.r.l. Strada Gabannone, 8/10 I – 15030 Terruggia (AL)</p>
Signed in the name and on behalf of / <i>Signed for and on behalf of:</i>	Identification and signature of the person authorised to draw up the declaration on behalf of the manufacturer <i>Identity and signature of the person empowered to draw up the declaration on behalf of the manufacturer</i>
	<p style="text-align: center;">Person authorized by the company Sesamo S.r.l. Strada Gabannone, 8/10 I – 15030 Terruggia (AL)</p>

Terruggia (AL) / Italy : **DD/MM/YY**